

ENGINE > PRECAUTION

1.IGNITION SWITCH EXPRESSIONS

1. The type of ignition switch used on this model differs according to the specifications of the vehicle. The expressions listed in the table below are used in this section.

| Expression | Ignition Switch (position) | Engine Switch (condition) |
|--------------------------|----------------------------|---------------------------|
| Ignition Switch off | LOCK | Off |
| Ignition Switch on (IG) | ON | On (IG) |
| Ignition Switch on (ACC) | ACC | On (ACC) |
| Engine Start | START | Start |

ENGINE > ON-VEHICLE INSPECTION

1. INSPECT ENGINE COOLANT

2. INSPECT ENGINE OIL

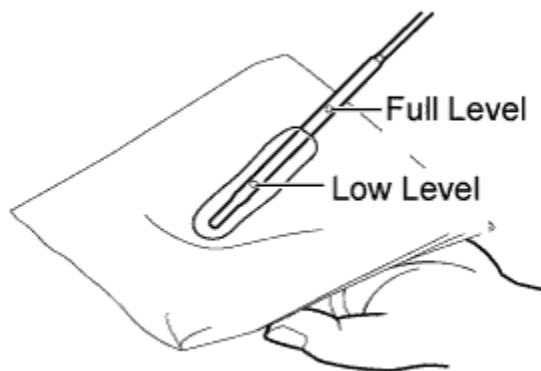

1. Check engine oil level.
 1. Warm up the engine, stop the engine and wait 5 minutes. The oil level should be between the dipstick's low level mark and full level mark. If low, check for leakage and add oil up to the full level mark.

NOTICE:
Do not fill with engine oil to above the full level mark.

Recommended Viscosity (SAE)

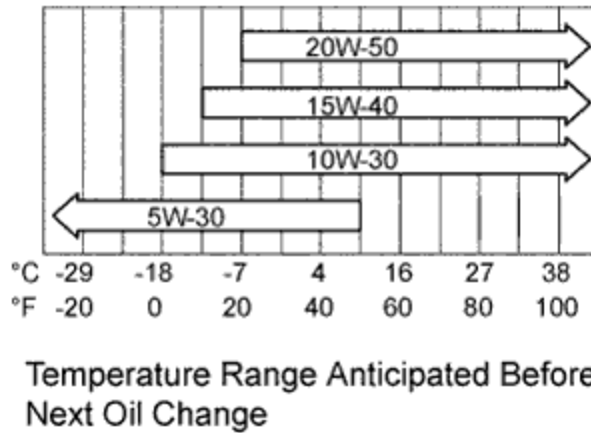

2. Check engine oil quality.
 1. Check the oil for deterioration, water contamination, discoloration and thinning.
If the quality is visibly poor, replace the oil.

Oil grade:
20W-50 and 15W-40:
API grade SL or SM multigrade engine oil
10W-30 and 5W-30:
API grade SL "Energy-Conserving" "Energy-Conserving SM or ILSAC multigrade engine oil"

3. INSPECT BATTERY

4. INSPECT AIR CLEANER FILTER ELEMENT SUB-ASSEMBLY

1. Remove the air cleaner filter element from the cylinder head cover sub-assembly.
2. Visually check that there is no dirt, clogging, /or damage to the air cleaner filter element.

HINT:

- If there is any dirt or a clog on the air cleaner filter element, clean it with compressed air.
- If any dirt or a clog remains even after cleaning the air cleaner filter element with compressed air, replace it.

5. INSPECT SPARK PLUG

NOTICE:

- Do not use a wire brush for cleaning.
- Do not attempt to adjust the electrode gap of a used spark plug.

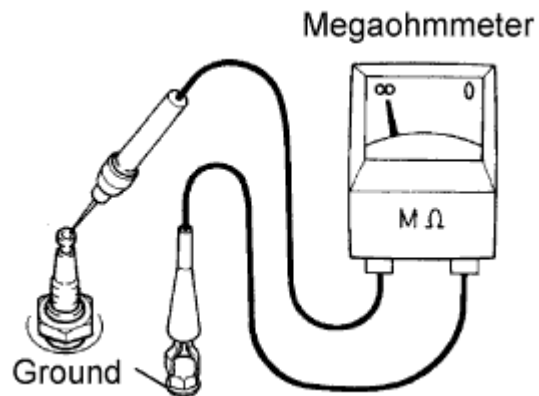

1. Check the electron.
 1. Using a megaohmmeter, measure the insulation resistance.

Standard resistance:
10 MΩ or more

If the resistance is less than the specified value, proceed to step (*3).

HINT:

If a megaohmmeter is not available, perform the following simple inspection instead.

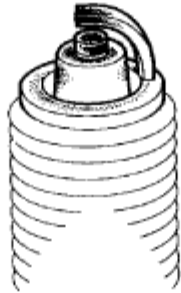

P03783

2. Alternative inspection method:

1. Quickly accelerate the engine to 4,000 rpm 5 times.
2. Remove the spark plug.
3. Visually check the spark plug.
4. If the electrode is dry, the spark plug is functioning. Proceed to step 2.
5. If the electrode is damp, proceed to steps (*1), (*2) and (*3).
6. Install the spark plug.

3. Check the spark plug for any damage to its threads and insulator. (*1)
If there is any damage, replace the spark plug.

Recommended spark plug:

| Supplier | Parts code |
|----------|------------|
| DENSO | K20HR-U11 |

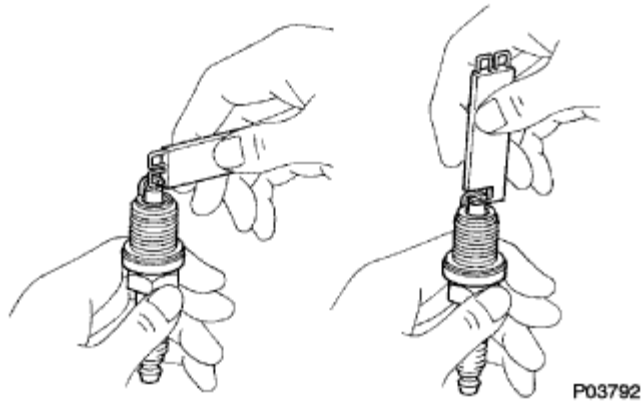

4. Check the spark plug electrode gap. (*2)

Maximum electrode gap for used spark plug:
1.3 mm (0.051 in.)

If the gap is greater than the maximum, replace the spark plug.

Correct electrode gap for new spark plug:
1.0 to 1.1 mm (0.039 to 0.043 in.)

NOTICE:

Bend only the base of the ground electrode when adjusting the gap of a new spark plug.

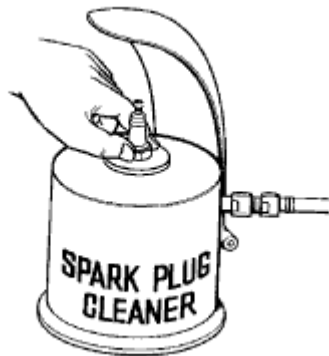

B62019

5. Clean the spark plugs. (*3)

If the electrode has traces of wet carbon, clean the electrode with a spark plug cleaner and then dry it.

Air pressure:
588 kPa (6 kgf/cm², 85psi)

Duration:

20 seconds or less

HINT:

Only use the spark plug cleaner when the electrode is free of oil. If the electrode has traces of oil, use gasoline to clean off the oil before using the spark plug cleaner.

6. INSPECT IGNITION TIMING

NOTICE:

- Turn all the electrical systems and the A/C off.
 - Inspect the ignition timing with the cooling fan off.
 - When checking the ignition timing, shift the transmission to the neutral position.
1. Warm up and stop the engine.

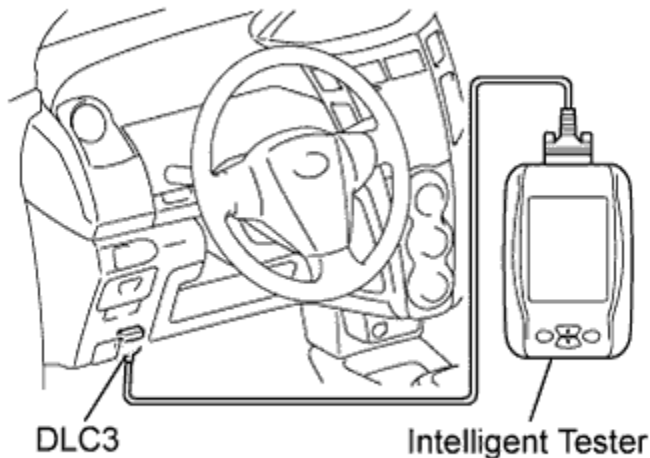

2. When using the intelligent tester:
 1. Connect the intelligent tester to the DLC3.
 2. Turn the Ignition Switch on (IG).
 3. Select the following menu items:
Powertrain / Engine and ECT / Active Test / TE1 (TC) / ON.

HINT:

Refer to the intelligent tester operator's manual for further information regarding the selection of Active Test.

4. Inspect the ignition timing during idling.

Ignition timing:

8 to 12° BTDC

5. Select the following menu items:
TE1 (TC) / OFF
6. Turn the Ignition Switch off.
7. Disconnect the intelligent tester from the DLC3.

3. When not using the intelligent tester:

1. Remove the air cleaner cap sub-assembly ().

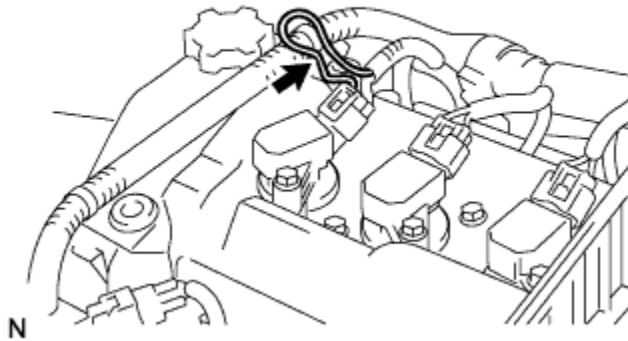

2. Install the tester terminal of a timing light onto the position shown in the illustration.

NOTICE:

- Use a timing light that detects the first signal.
- Wrap the wire harness with tape after checking.

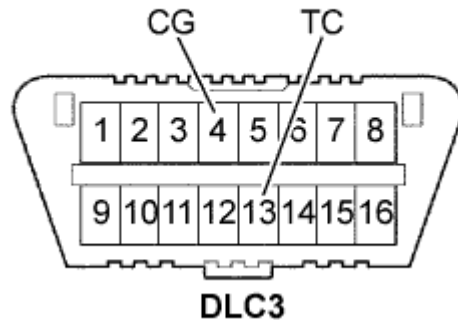

3. Using SST, connect terminals 13 (TC) and 4 (CG) of the DLC3.

SST

09843-18040

NOTICE:

Check the terminal numbers before connecting them. Connecting the wrong terminals could damage the engine.

4. Turn the Ignition Switch on (IG).
5. Inspect the ignition timing during idling.

Ignition timing:

0 to 15° BTDC

HINT:

Run the engine speed at 1,000 to 1,300 rpm for 5 seconds, then check that the engine speed returns to the idling speed.

6. Disconnect terminals 13 (TC) and 4 (CG) of the DCL3.
7. Turn the Ignition Switch off.
8. Remove the timing light.
9. Install the air cleaner cap sub-assembly ().

7. INSPECT ENGINE IDLING SPEED

NOTICE:

- Turn all the electrical systems and the A/C off.

- Inspect the engine idling speed with the cooling fan off.
 - When checking the idling speed, shift the transmission to the neutral position.
1. Warm up and stop the engine.

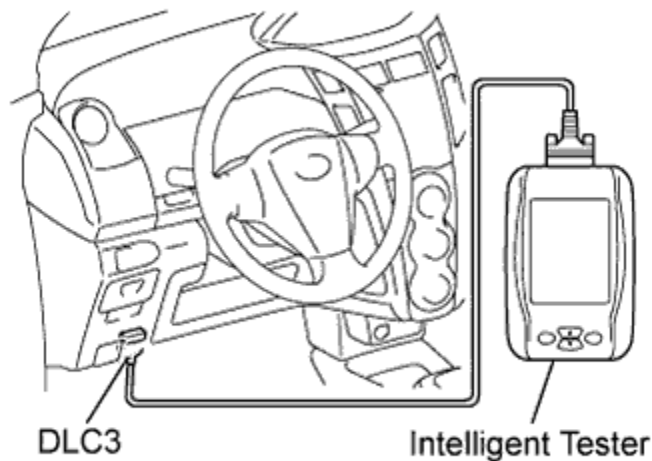

2. When using the intelligent tester:

1. Connect the intelligent tester to the DLC3.
2. Turn the Ignition Switch on (IG).
3. Select the following menu items:
Powertrain / Engine and ECT / Data List / Engine SPD.

HINT:

Refer to the intelligent tester operator's manual for further information regarding the selection of Data List.

4. Inspect the engine idling speed.

Idling speed:

730 to 830 rpm

5. Turn the Ignition Switch off.
6. Disconnect the intelligent tester from the DCL3.

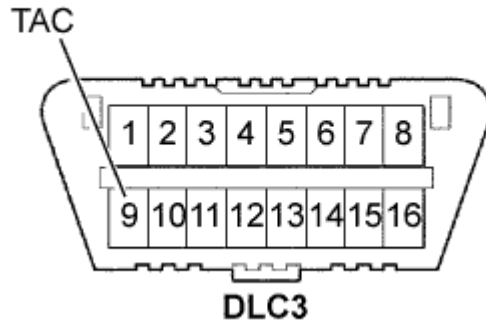

3. When not using an intelligent tester:

1. Install SST to terminal 9 (TAC) of the DLC3, then connect a tachometer.

SST

09843-18040

NOTICE:

Check the terminal numbers before connecting them. Connecting the wrong terminals could damage the engine.

2. Turn the Ignition Switch on (IG).
3. Inspect the engine idling speed.

Idling speed:

730 to 830 rpm

4. Turn the Ignition Switch off.
5. Disconnect the tachometer.
6. Remove SST from terminal 9 (TAC).

8. INSPECT COMPRESSION

1. Warm up and stop the engine.
2. Remove the air cleaner cap sub-assembly ().
3. Remove the 3 ignition coils ().

4. Remove the 3 spark plugs.
5. Disconnect the 3 fuel injector connectors.

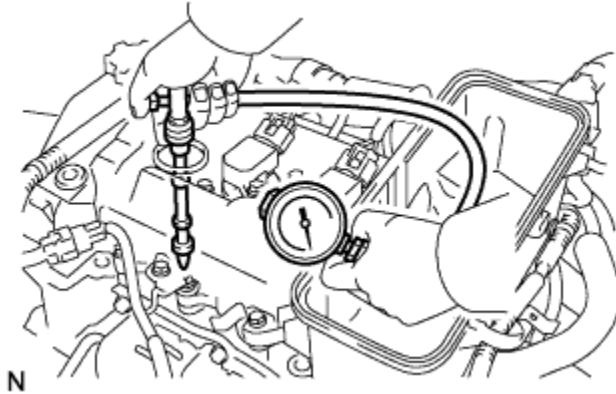

6. Inspect the cylinder compression pressure.
 1. Install SST (compression gauge) into the spark plug hole.

SST
09992-00500

2. Fully open the throttle.
3. While cranking the engine, measure the compression pressure.

Compression pressure (Normal condition):
1,422 kPa (14.5 kgf/cm², 206 psi)

Minimum pressure:
1,079 kPa (11.0 kgf/cm², 156 psi)

Difference between each cylinder:
147 kPa (1.5 kgf/cm², 21 psi) or less

NOTICE:

- Use a fully-charged battery so the engine speed can be increased to 400 rpm or more.
 - Inspect the other cylinders in the same way.
 - Measure the compression as quickly as possible.
4. If the cylinder compression is low, pour a small amount of engine oil into the cylinder through the spark plug hole, then inspect it again.

HINT:

- If adding oil increases the compression, the piston rings and/or cylinder bore may be worn or damaged.
 - If the pressure remains low, the valve may be stuck or seated improperly, or there may be leakage from the gasket.
7. Connect the 3 fuel injector connectors.
 8. Install the 3 spark plugs.

Torque:
25 N*m { 255 kgf*cm , 18 ft.*lbf }
 9. Install the 3 ignition coils ().
 10. Install the air cleaner cap sub-assembly ().

9. INSPECT CO/HC

HINT:

The ECM controls the concentration of CO/HC in the emission gas.

1. Start the engine.
2. Run the engine at 2,500 rpm for approximately 180 seconds.
3. Insert the CO/HC meter testing probe at least 40 cm (1.3 ft) into the tailpipe during idling.
4. Check the CO/HC concentration during idling and when running at 2,500 rpm.

Standard:

CO concentration:

0.2 % or less

HC concentration:

70 ppm or less

If the CO/HC concentration does not comply with the regulations, troubleshoot in the order given below.

- Check the heated oxygen sensor operation (and/or).
- See the table below for possible causes, then inspect the applicable parts and repair them if necessary.

| CO | HC | Problems | Causes |
|--------|------|--|---|
| Normal | High | Rough idling | 3. Faulty ignition: <ul style="list-style-type: none"> • Fouled, shorted or improperly gapped plugs 4. Incorrect valve clearance 5. Leakage from intake and exhaust valves 6. Leakage from cylinders |
| Low | High | Rough idling (Fluctuating HC reading) | 7. Lean mixture causing misfire 8. Faulty SFI systems: <ul style="list-style-type: none"> • Faulty pressure regulator • Faulty engine coolant temperature sensor • Faulty mass air flow meter • Faulty ECM • Faulty injectors • Faulty throttle body |
| High | High | Rough idling (Black smoke from exhaust) | 9. Faulty SFI systems: <ul style="list-style-type: none"> • Faulty pressure regulator • Faulty engine coolant temperature sensor • Faulty mass air flow meter • Faulty ECM • Faulty injectors • Faulty throttle body |

DRIVE BELT > COMPONENTS

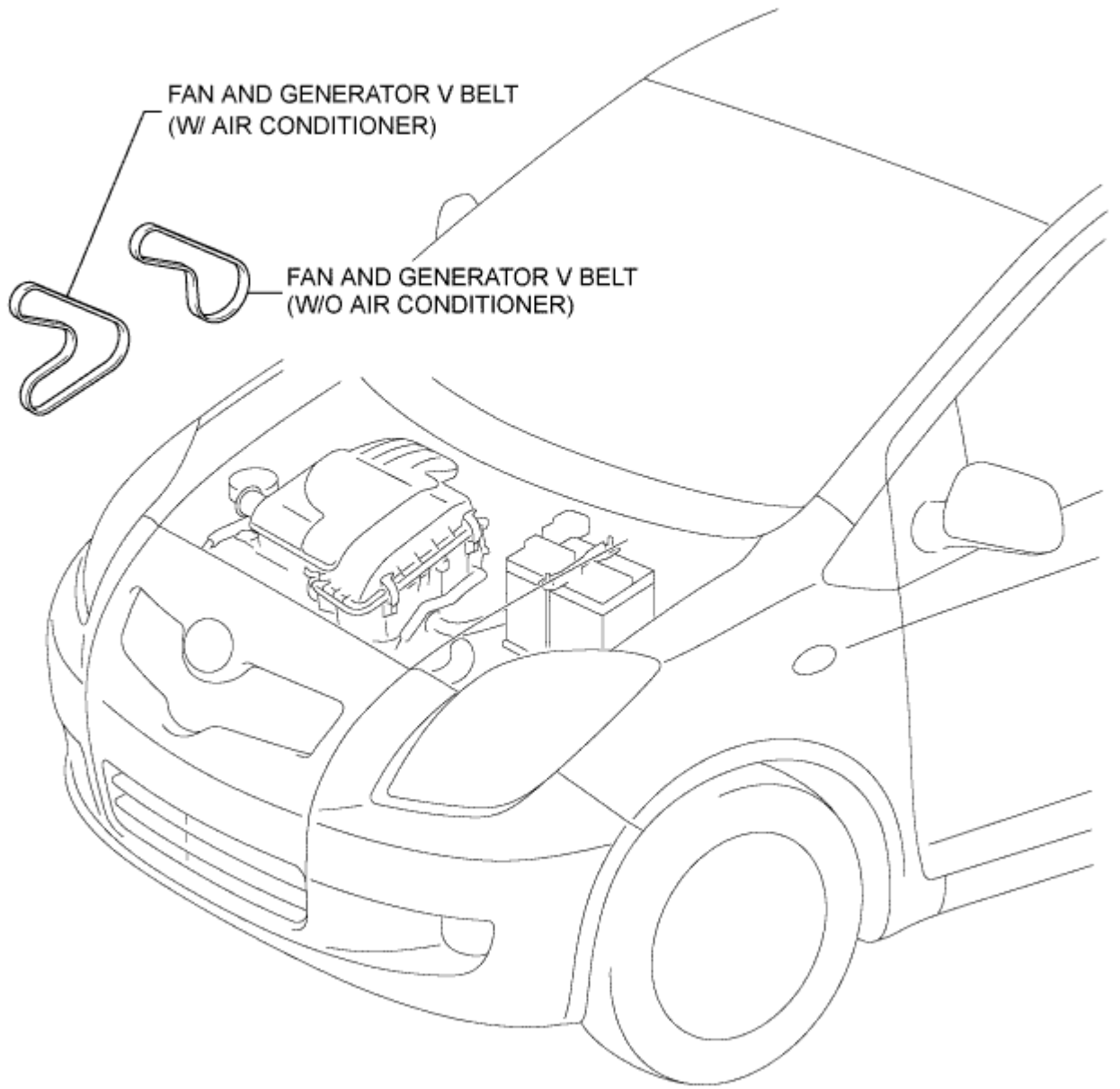

Y

DRIVE BELT > REMOVAL

1. REMOVE FAN AND GENERATOR V BELT

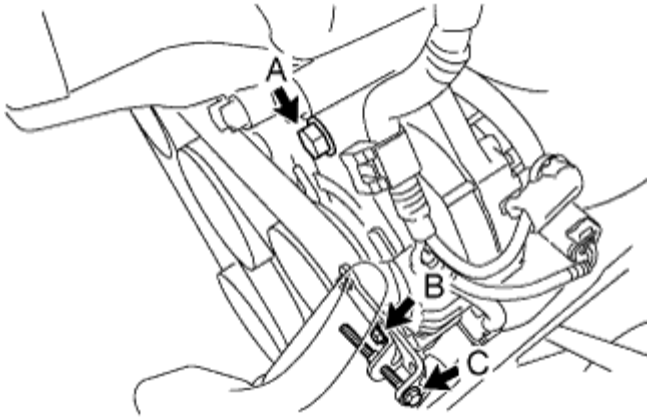

1. Loosen bolt A.
2. Loosen bolt B.
3. Loosen bolt C.
4. Release the drive belt tension and remove the fan and generator V belt.

DRIVE BELT > INSPECTION

1. INSPECT FAN AND GENERATOR V BELT

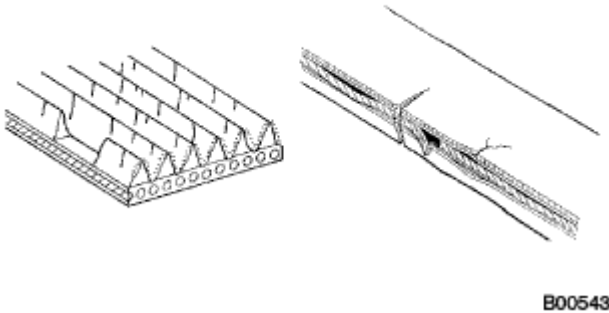

1. Visually check the belt for excessive wear, frayed cords etc.
If any defect is found, replace the belt.

HINT:

Cracks on the rib side of a belt are considered acceptable. If the belt has pieces missing from the ribs, it should be replaced.

DRIVE BELT > INSTALLATION

1. INSTALL FAN AND GENERATOR V BELT

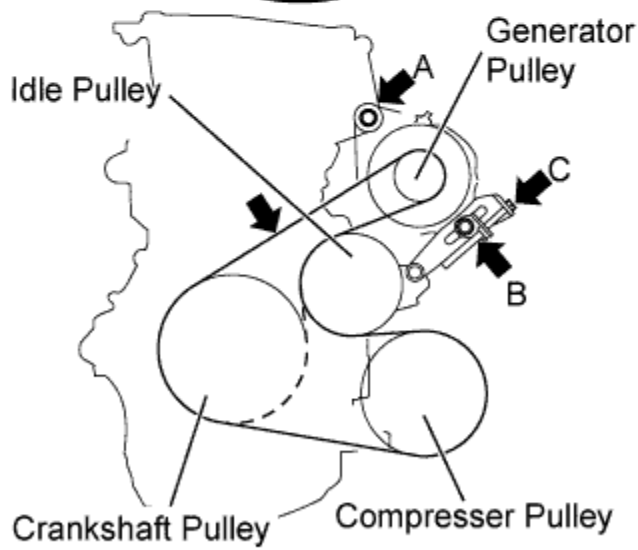
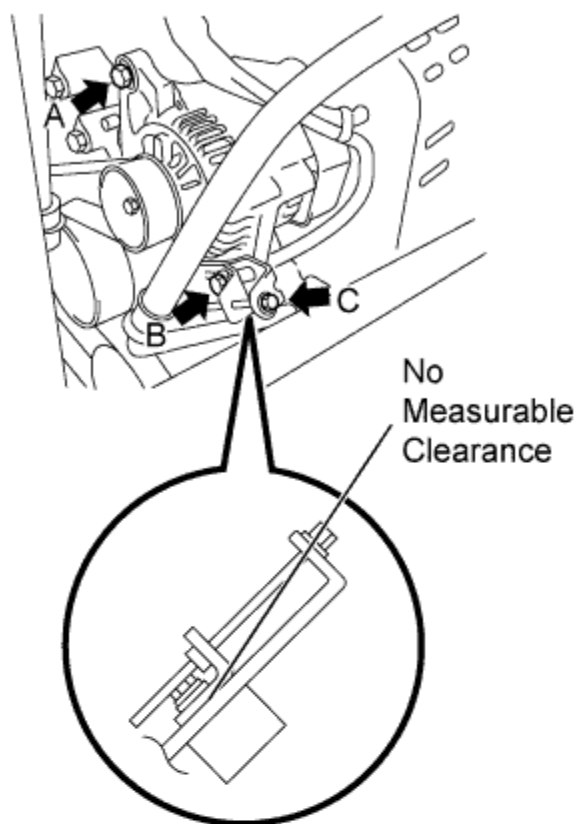

—— w/ Air Conditioner
 - - - - w/o Air Conditioner

c

1. Install the fan and generator V belt.

2. Gently tighten bolt B until there is no measurable clearance.
3. Turn bolt C to adjust the tension of the fan and generator V belt.
4. Inspect the fan and generator V belt.
5. Tighten bolt B.

Torque:

34 N*m { 347 kgf*cm , 25 ft.*lbf }

6. Tighten bolt A.

Torque:

54 N*m { 551 kgf*cm , 40 ft.*lbf }

7. Visually check the generator wiring and listen for abnormal noise.
 1. Check that the wiring is in good condition.
 2. Check that there is no abnormal noise from the generator while the engine is running.



Correct



Wrong Wrong

8. Inspect the discharge warning light circuit.
 1. Turn the ignition switch to the ON position. Check that the discharge warning light illuminates.
 2. Start the engine. Check that the light goes off.

2. INSPECT DRIVE BELT DEFLECTION AND TENSION

w/o Air Conditioner

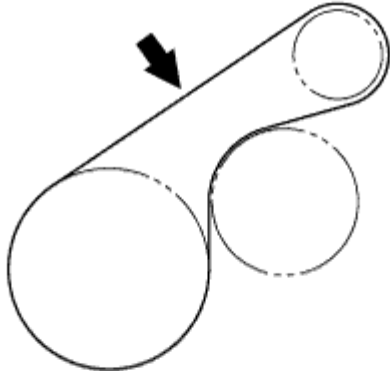

w/ Air Conditioner

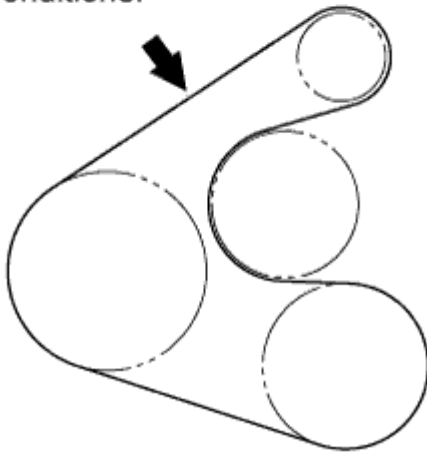

c

1. Check the belt deflection by pressing on the belt at the points indicated by the arrow marks in the illustration.

Deflection:

| Item | Specified Condition |
|-----------|-------------------------------|
| New belt | 7 to 8 mm (0.28 to 0.31 in.) |
| Used belt | 9 to 11 mm (0.35 to 0.43 in.) |

If the belt deflection is not as specified, adjust it.

HINT:

- The most appropriate force for the adjustment above is 98 N (10 kgf, 22 lbf).

- New belt refers to a belt which has been used on a running engine for less than 5 minutes.
- Used belt refers to a belt which has been used on a running engine for 5 minutes or more.
- After installing a belt, check that it fits properly in the ribbed grooves.
- Check with your hand to confirm that the belt has not slipped out of the groove on the bottom of the pulley.
- After installing a new belt, run the engine for about 5 minutes and recheck the belt tension.

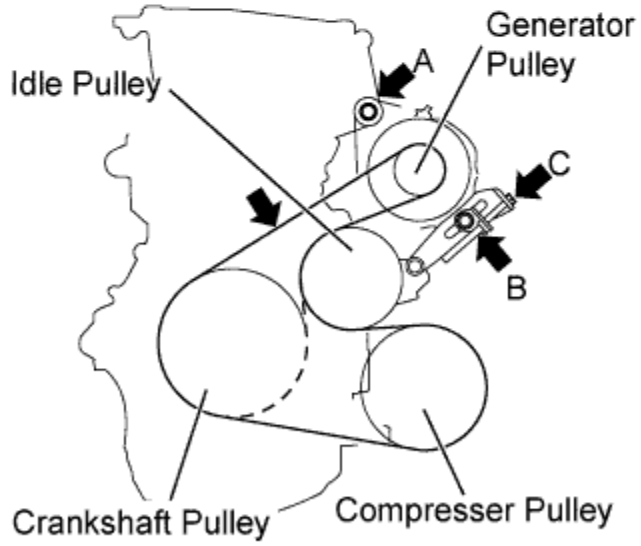
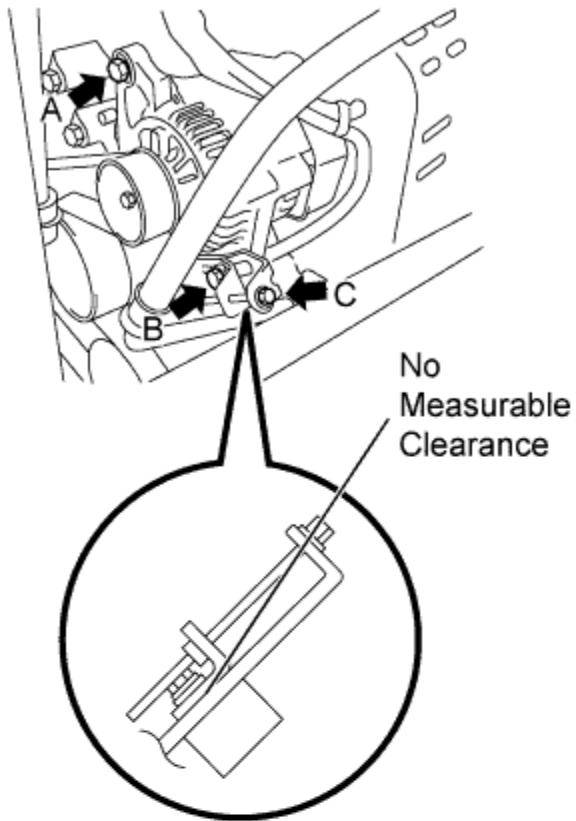

—— w/ Air Conditioner

----- w/o Air Conditioner

c

2. Adjust fan and generator V belt tension.

1. Loosen bolt A.
2. Loosen bolt B.
3. Gently tighten bolt B until there is no measurable clearance.
4. Turn bolt C to adjust the tension of the fan and generator V belt.
5. Tighten bolt B.

Torque:

34 N*m { 347 kgf*cm , 25 ft.*lbf }

6. Tighten bolt A.

Torque:

54 N*m { 551 kgf*cm , 40 ft.*lbf }

3. Visually check the generator wiring and listen for abnormal noises.
 1. Check that the wiring is in good condition.
 2. Check that there is no abnormal noise from the generator while the engine is running.



4. Inspect the discharge warning light circuit.
 1. Turn the ignition switch to the ON position. Check that the discharge warning light illuminates.
 2. Start the engine. Check that the light goes off.

VALVE CLEARANCE > ADJUSTMENT

1. DISCONNECT CABLE FROM NEGATIVE BATTERY TERMINAL

2. REMOVE AIR CLEANER CAP SUB-ASSEMBLY

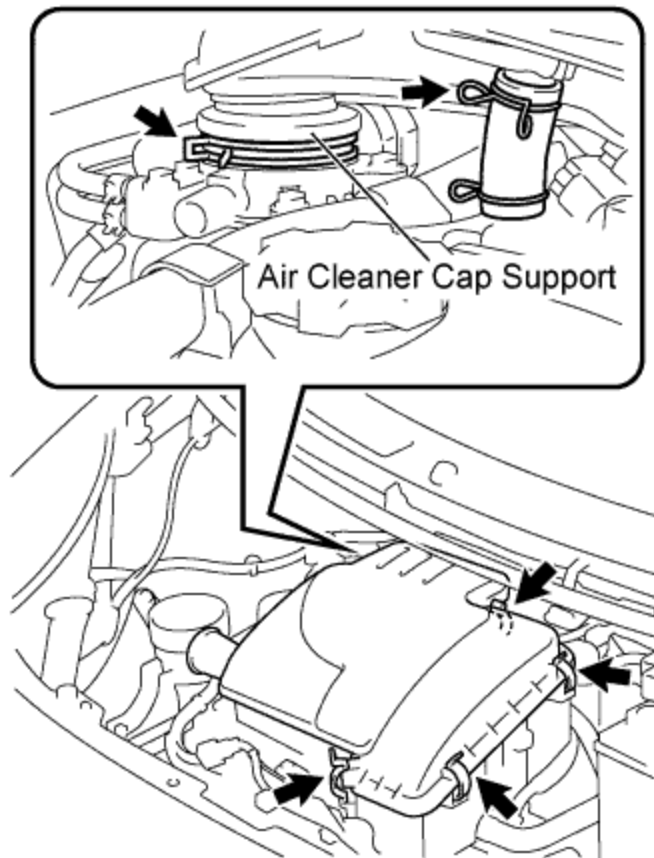

Y

1. Remove the 4 clamps.
2. Remove the 2 clamps and remove the air cleaner cap.

3. REMOVE AIR CLEANER FILTER ELEMENT SUB-ASSEMBLY

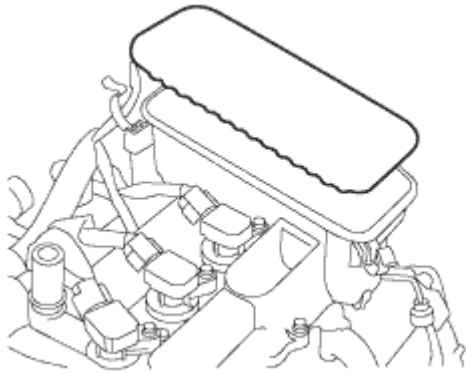

1. Remove the air cleaner filter element from the cylinder head cover.

4. REMOVE IGNITION COIL NO. 1

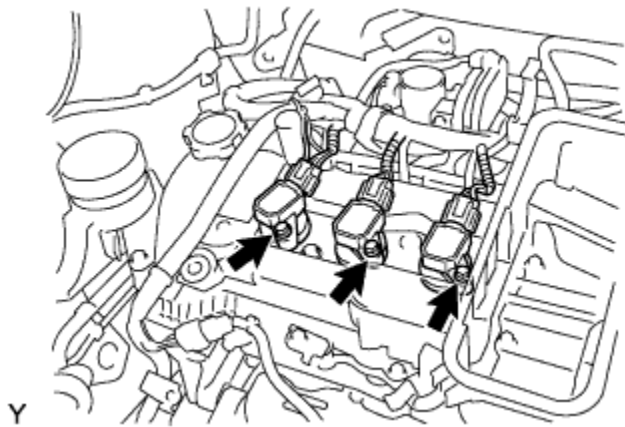

1. Disconnect the 3 connectors.
2. Remove the 3 bolts and 3 ignition coils.

5. REMOVE CYLINDER HEAD COVER SUB-ASSEMBLY

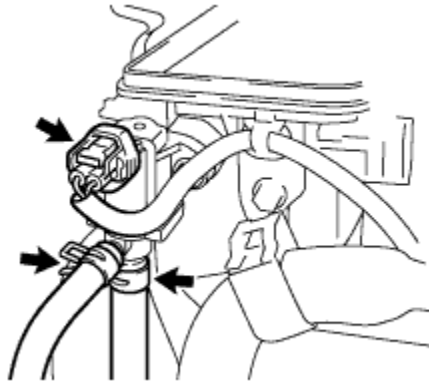

N

1. Disconnect the VSV connector and disengage the wire harness clamp.
2. Disconnect vapor feed hoses No. 1 and No. 2.

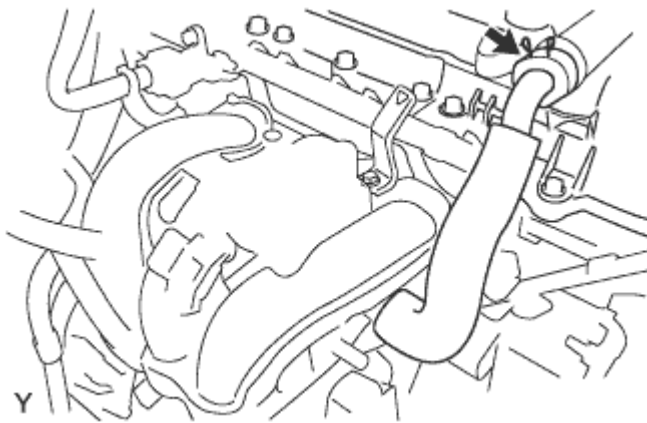

3. Disconnect the ventilation hose.

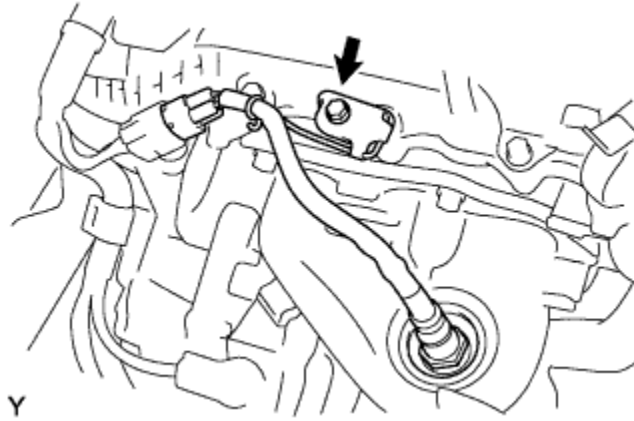

4. Remove the bolt and separate the oxygen sensor wire harness.
5. Separate the wire harness.

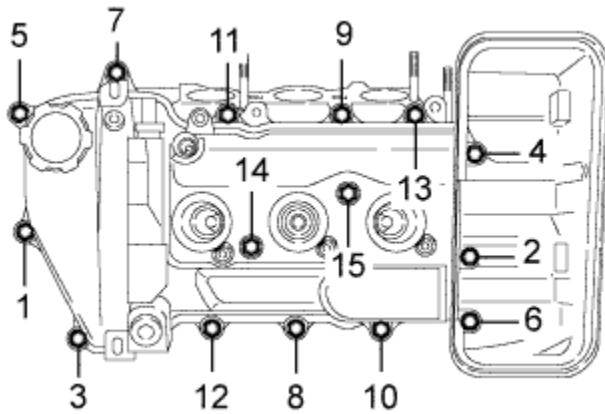

6. Remove the 13 bolts and 2 nuts in the order shown in the illustration and remove the cylinder head cover with the gasket.

6. SET NO. 1 CYLINDER TO TDC/COMPRESSION

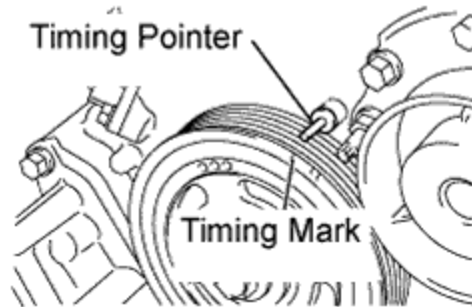
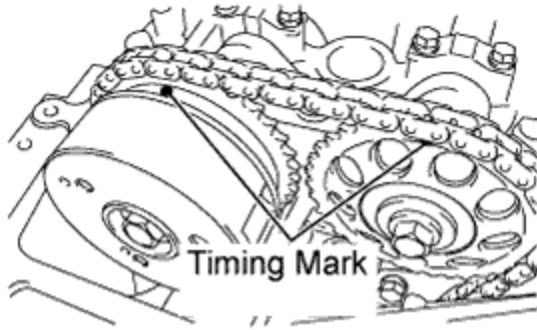

Y

1. Turn the crankshaft pulley clockwise to align the timing mark on the pulley with the timing pointer of the timing chain cover.
2. Make sure that the timing mark of the camshaft sprocket is at the top.

HINT:

If the matchmarks do not align, turn the crankshaft clockwise one complete revolution and then check that they align.

7. INSPECT VALVE CLEARANCE

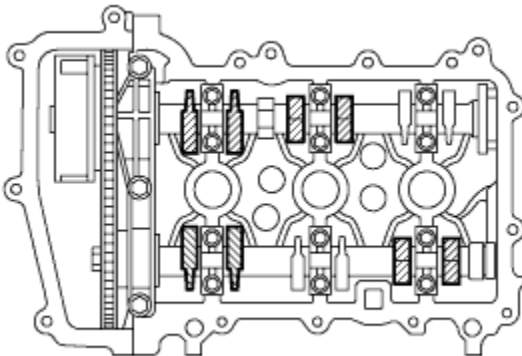

N

1. Check only the valves indicated.

1. Using a feeler gauge, measure the clearance between the valve lifter and camshaft.

Valve clearance (Cold):

Intake side:

0.145 to 0.235 mm (0.00571 to 0.00925 in.)

Exhaust side:

0.275 to 0.365 mm (0.01083 to 0.01437 in.)

HINT:

Insert the feeler gauge from the spark plug side (center).

2. Record any out-of-specification valve clearance measurements. They will be used later to determine the required replacement valve lifters.

2. Turn the crankshaft 1 revolution (360°).

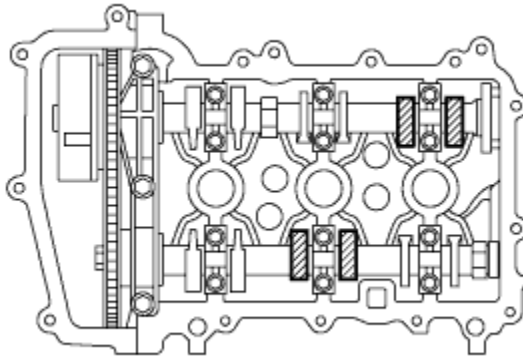

N

3. Check only the valves indicated.

1. Using a feeler gauge, measure the clearance between the valve lifter and camshaft.

Valve clearance (Cold):

Intake side:

0.145 to 0.235 mm (0.00571 to 0.00925 in.)

Exhaust side:

0.275 to 0.365 mm (0.01083 to 0.01437 in.)

HINT:

Insert the feeler gauge from the spark plug side (center).

2. Record any out-of-specification valve clearance measurements. They will be used later to determine the required replacement valve lifters.

8. ADJUST VALVE CLEARANCE

1. Remove the No. 1 and No. 2 camshafts ().
2. Remove the valve lifters ().

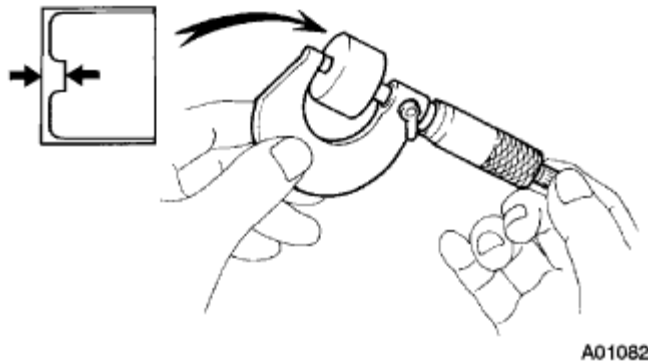

3. Using a micrometer, measure the thickness of the removed valve lifters.
4. Calculate the thickness of a new lifter so that the valve clearance comes within the specified value.

| | |
|---|--------------------------|
| A | Thickness of new lifter |
| B | Thickness of used lifter |
| C | Measured valve clearance |

5. Valve clearance:
6. Intake $A = B + (C - 0.18 \text{ mm (0.0071 in.)})$
7. Exhaust $A = B + (C - 0.31 \text{ mm (0.0122 in.)})$
8. HINT:
 - Select a new lifter with a thickness as close to the calculated values as possible.
 - Lifters are available in 29 sizes in increments of 0.020 mm (0.0008 in.), from 5.12 mm (0.2016 in.) to 5.68 mm (0.2236 in.).
 - Refer to the New Lifter Thickness Table on the next 2 pages.

5. Install the valve lifters ().

6. Install the No. 1 and No. 2 camshafts ().

Valve Lifter Selection Chart (Intake)

| Measured Clearance mm (in.) | Installed Lifter Thickness mm (in.) | | | | | | | | | | | | | | | | |
|---------------------------------|--|----------------|----------------|----------------|----------------|----------------|----------------|----------------|----------------|----------------|----------------|----------------|----------------|----------------|----------------|----------------|--|
| | | 5.120 (0.2016) | 5.140 (0.2024) | 5.160 (0.2031) | 5.180 (0.2039) | 5.200 (0.2047) | 5.210 (0.2051) | 5.220 (0.2055) | 5.230 (0.2059) | 5.240 (0.2063) | 5.250 (0.2067) | 5.260 (0.2071) | 5.270 (0.2075) | 5.280 (0.2079) | 5.290 (0.2083) | 5.300 (0.2087) | |
| 0.000 - 0.030 (0.0000 - 0.0012) | | | | | | | | | | | | | | | | | |
| 0.031 - 0.050 (0.0012 - 0.0020) | | | | | | | | | | | | | | | | | |
| 0.051 - 0.070 (0.0020 - 0.0028) | | | | | | | | | | | | | | | | | |
| 0.071 - 0.090 (0.0028 - 0.0035) | | | | | | | | | | | | | | | | | |
| 0.091 - 0.110 (0.0035 - 0.0043) | | | | | | | | | | | | | | | | | |
| 0.111 - 0.130 (0.0043 - 0.0051) | | | | | | | | | | | | | | | | | |
| 0.131 - 0.149 (0.0051 - 0.0059) | | | | | | | | | | | | | | | | | |
| 0.150 - 0.250 (0.0059 - 0.0098) | | | | | | | | | | | | | | | | | |
| 0.251 - 0.270 (0.0098 - 0.0106) | | | | | | | | | | | | | | | | | |
| 0.271 - 0.290 (0.0107 - 0.0114) | | | | | | | | | | | | | | | | | |
| 0.291 - 0.310 (0.0115 - 0.0122) | | | | | | | | | | | | | | | | | |
| 0.311 - 0.330 (0.0122 - 0.0130) | | | | | | | | | | | | | | | | | |
| 0.331 - 0.350 (0.0130 - 0.0138) | | | | | | | | | | | | | | | | | |
| 0.351 - 0.370 (0.0138 - 0.0146) | | | | | | | | | | | | | | | | | |
| 0.371 - 0.390 (0.0146 - 0.0154) | | | | | | | | | | | | | | | | | |
| 0.391 - 0.410 (0.0154 - 0.0161) | | | | | | | | | | | | | | | | | |
| 0.411 - 0.430 (0.0162 - 0.0169) | | | | | | | | | | | | | | | | | |
| 0.431 - 0.450 (0.0170 - 0.0177) | | | | | | | | | | | | | | | | | |
| 0.451 - 0.470 (0.0178 - 0.0185) | | | | | | | | | | | | | | | | | |
| 0.471 - 0.490 (0.0185 - 0.0193) | | | | | | | | | | | | | | | | | |
| 0.491 - 0.510 (0.0193 - 0.0201) | | | | | | | | | | | | | | | | | |
| 0.511 - 0.530 (0.0201 - 0.0209) | | | | | | | | | | | | | | | | | |
| 0.531 - 0.550 (0.0209 - 0.0217) | | | | | | | | | | | | | | | | | |
| 0.551 - 0.570 (0.0217 - 0.0224) | | | | | | | | | | | | | | | | | |
| 0.571 - 0.590 (0.0225 - 0.0232) | | | | | | | | | | | | | | | | | |
| 0.591 - 0.610 (0.0233 - 0.0240) | | | | | | | | | | | | | | | | | |
| 0.611 - 0.630 (0.0241 - 0.0248) | | | | | | | | | | | | | | | | | |
| 0.631 - 0.650 (0.0248 - 0.0256) | | | | | | | | | | | | | | | | | |
| 0.651 - 0.670 (0.0256 - 0.0264) | | | | | | | | | | | | | | | | | |
| 0.671 - 0.690 (0.0264 - 0.0272) | | | | | | | | | | | | | | | | | |
| 0.691 - 0.710 (0.0272 - 0.0280) | | | | | | | | | | | | | | | | | |
| 0.711 - 0.730 (0.0280 - 0.0287) | | | | | | | | | | | | | | | | | |
| 0.731 - 0.750 (0.0288 - 0.0295) | | | | | | | | | | | | | | | | | |
| 0.751 - 0.770 (0.0296 - 0.0303) | | | | | | | | | | | | | | | | | |

Valve Lifter Selection Chart (Exhaust)

| | | Measured Clearance mm (in.) | Installed Lifter Thickness mm (in.) |
|--|--|---------------------------------|--|
| | | 0.000 - 0.030 (0.0000 - 0.0012) | 5.120 (0.2018) |
| | | 0.031 - 0.050 (0.0012 - 0.0020) | 5.140 (0.2024) |
| | | 0.051 - 0.070 (0.0020 - 0.0028) | 5.160 (0.2031) |
| | | 0.071 - 0.090 (0.0028 - 0.0035) | 5.180 (0.2039) |
| | | 0.091 - 0.110 (0.0035 - 0.0043) | 5.200 (0.2047) |
| | | 0.111 - 0.130 (0.0043 - 0.0051) | 5.220 (0.2055) |
| | | 0.131 - 0.150 (0.0052 - 0.0059) | 5.230 (0.2059) |
| | | 0.151 - 0.170 (0.0059 - 0.0067) | 5.240 (0.2063) |
| | | 0.171 - 0.190 (0.0067 - 0.0075) | 5.250 (0.2067) |
| | | 0.191 - 0.210 (0.0075 - 0.0083) | 5.260 (0.2071) |
| | | 0.211 - 0.230 (0.0083 - 0.0091) | 5.270 (0.2075) |
| | | 0.231 - 0.249 (0.0091 - 0.0098) | 5.280 (0.2079) |
| | | 0.250 - 0.269 (0.0098 - 0.0106) | 5.290 (0.2083) |
| | | 0.269 - 0.287 (0.0106 - 0.0114) | 5.300 (0.2087) |
| | | 0.288 - 0.306 (0.0114 - 0.0122) | 5.310 (0.2091) |
| | | 0.307 - 0.325 (0.0122 - 0.0130) | 5.320 (0.2094) |
| | | 0.326 - 0.344 (0.0130 - 0.0138) | 5.330 (0.2098) |
| | | 0.345 - 0.363 (0.0138 - 0.0146) | 5.340 (0.2102) |
| | | 0.364 - 0.382 (0.0146 - 0.0154) | 5.350 (0.2106) |
| | | 0.383 - 0.401 (0.0154 - 0.0162) | 5.360 (0.2110) |
| | | 0.402 - 0.420 (0.0162 - 0.0169) | 5.370 (0.2114) |
| | | 0.421 - 0.439 (0.0169 - 0.0177) | 5.380 (0.2118) |
| | | 0.440 - 0.458 (0.0177 - 0.0185) | 5.390 (0.2122) |
| | | 0.459 - 0.477 (0.0185 - 0.0193) | 5.400 (0.2126) |
| | | 0.478 - 0.496 (0.0193 - 0.0201) | 5.410 (0.2130) |
| | | 0.497 - 0.515 (0.0201 - 0.0209) | 5.420 (0.2134) |
| | | 0.516 - 0.534 (0.0209 - 0.0217) | 5.430 (0.2138) |
| | | 0.535 - 0.553 (0.0217 - 0.0224) | 5.440 (0.2142) |
| | | 0.554 - 0.572 (0.0224 - 0.0232) | 5.450 (0.2146) |
| | | 0.573 - 0.591 (0.0232 - 0.0240) | 5.460 (0.2150) |
| | | 0.592 - 0.610 (0.0240 - 0.0248) | 5.470 (0.2154) |
| | | 0.611 - 0.629 (0.0248 - 0.0256) | 5.480 (0.2157) |
| | | 0.630 - 0.648 (0.0256 - 0.0264) | 5.490 (0.2161) |
| | | 0.649 - 0.667 (0.0264 - 0.0272) | 5.500 (0.2165) |
| | | 0.668 - 0.686 (0.0272 - 0.0280) | 5.510 (0.2169) |
| | | 0.687 - 0.705 (0.0280 - 0.0287) | 5.520 (0.2173) |
| | | 0.706 - 0.724 (0.0287 - 0.0295) | 5.530 (0.2177) |
| | | 0.725 - 0.743 (0.0295 - 0.0303) | 5.540 (0.2181) |
| | | 0.744 - 0.762 (0.0303 - 0.0311) | 5.550 (0.2185) |
| | | 0.763 - 0.781 (0.0311 - 0.0319) | 5.560 (0.2189) |
| | | 0.782 - 0.800 (0.0319 - 0.0327) | 5.570 (0.2193) |
| | | 0.801 - 0.819 (0.0327 - 0.0335) | 5.580 (0.2197) |
| | | 0.820 - 0.838 (0.0335 - 0.0343) | 5.590 (0.2201) |
| | | | 5.600 (0.2205) |
| | | | 5.620 (0.2213) |
| | | | 5.640 (0.2220) |
| | | | 5.660 (0.2228) |
| | | | 5.680 (0.2236) |

HINT:

| New lifter thickness mm (in.) | | | | | |
|-------------------------------|---------------|------------|---------------|------------|---------------|
| Lifter No. | Thickness | Lifter No. | Thickness | Lifter No. | Thickness |
| 12 | 5.12 (0.2016) | 32 | 5.32 (0.2094) | 52 | 5.52 (0.2173) |
| 14 | 5.14 (0.2024) | 34 | 5.34 (0.2102) | 54 | 5.54 (0.2181) |
| 16 | 5.16 (0.2031) | 36 | 5.36 (0.2110) | 56 | 5.56 (0.2189) |
| 18 | 5.18 (0.2039) | 38 | 5.38 (0.2118) | 58 | 5.58 (0.2197) |
| 20 | 5.20 (0.2047) | 40 | 5.40 (0.2126) | 60 | 5.60 (0.2205) |
| 22 | 5.22 (0.2055) | 42 | 5.42 (0.2134) | 62 | 5.62 (0.2213) |
| 24 | 5.24 (0.2063) | 44 | 5.44 (0.2142) | 64 | 5.64 (0.2220) |
| 26 | 5.26 (0.2071) | 46 | 5.46 (0.2150) | 66 | 5.66 (0.2228) |
| 28 | 5.28 (0.2079) | 48 | 5.48 (0.2157) | 68 | 5.68 (0.2236) |
| 30 | 5.30 (0.2087) | 50 | 5.50 (0.2165) | - | - |

9. INSTALL CYLINDER HEAD COVER SUB-ASSEMBLY

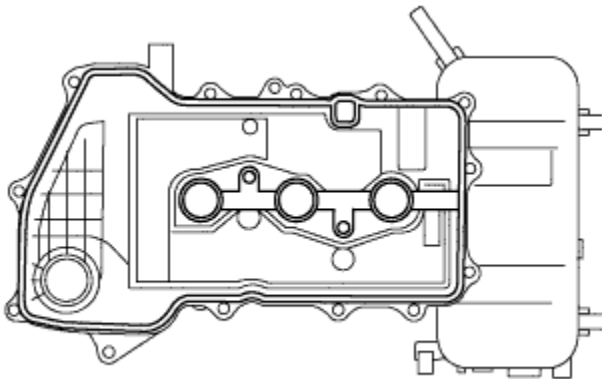

Y

1. Clean the cylinder head cover, cylinder head assembly and timing chain cover assembly.
2. Fit the cylinder head cover gasket into the gasket groove on the cover and onto the center bosses.

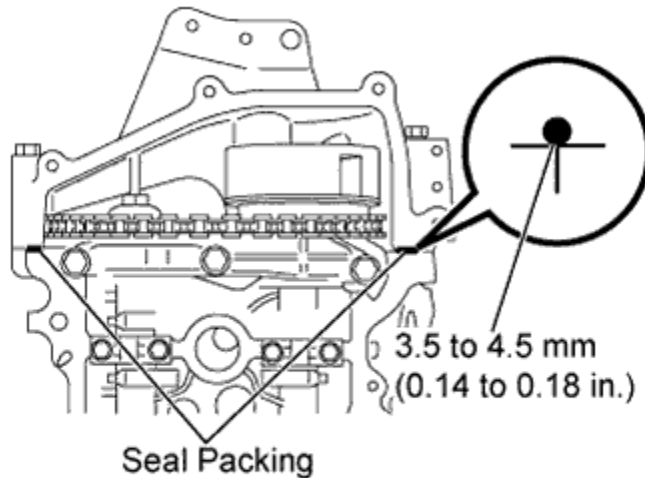

3. Apply a continuous bead of seal packing (diameter: 3.5 to 4.5 mm (0.14 to 0.18 in.)) to the contact surface between the cylinder head assembly and timing chain cover assembly, as shown in the illustration.

Seal Packing:

Part No. 08826-00080 or the equivalent

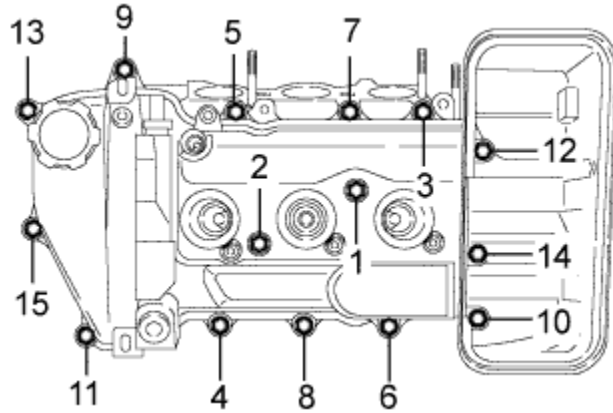

4. Install the bolts within 3 minutes of applying seal packing in the order shown in the illustration.

Torque:

7.7 N*m { 79 kgf*cm , 68 in.*lbf }

5. Tighten the bolts to the specified torque and make sure that bolts 1 and 2 are tightened to the specified torque shown in the illustration.
6. Install the wire harness.

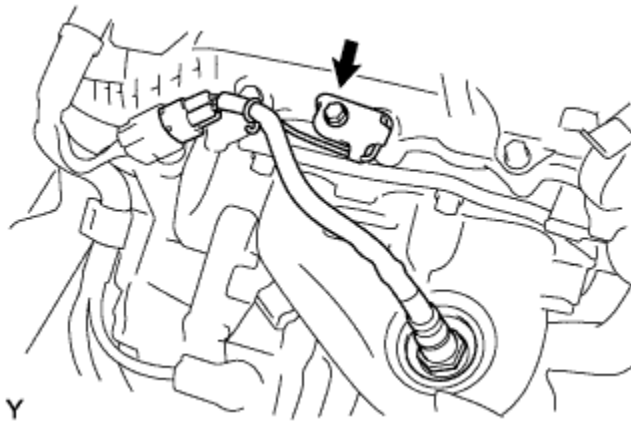

7. Install the oxygen sensor wire harness with the bolt.

Torque:

7.7 N*m { 79 kgf*cm , 68 in.*lbf }

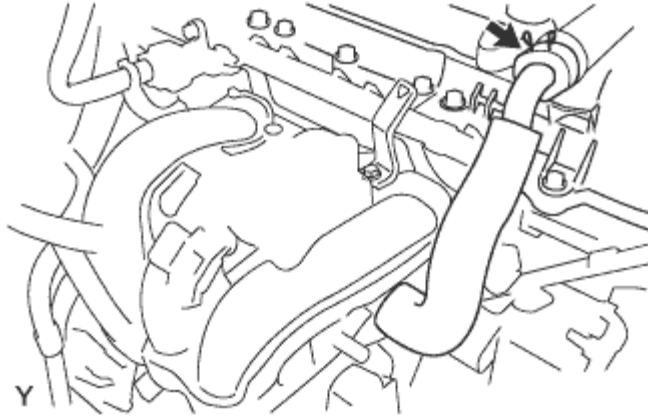

8. Connect the ventilation hose.

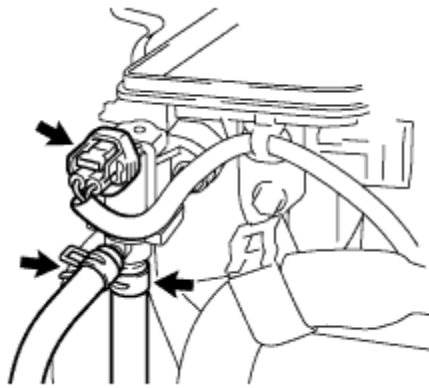

9. Connect vapor hoses No. 1 and No. 2.

10. Connect the VSV connector.

10. INSTALL IGNITION COIL NO. 1

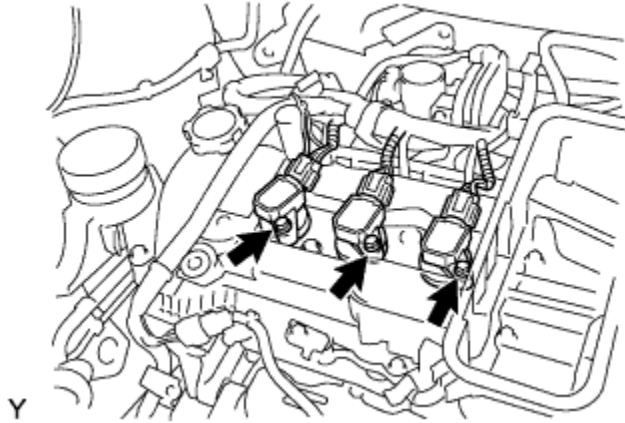

1. Install the 3 ignition coils with the 3 bolts.

Torque:
9.2 N*m { 94 kgf*cm , 81 in.*lbf }

2. Connect the 3 connectors.

11. INSTALL AIR CLEANER FILTER ELEMENT SUB-ASSEMBLY

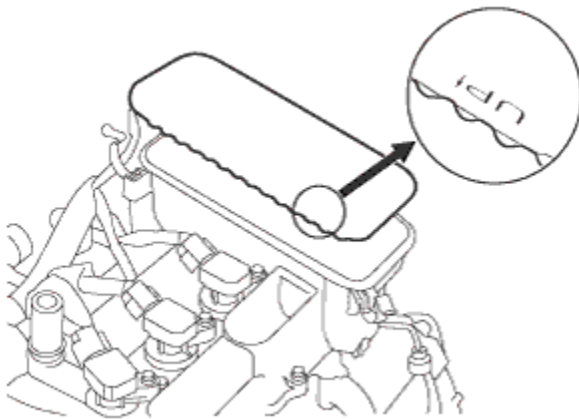

1. Install the air cleaner filter element as shown in the illustration.

12. INSTALL AIR CLEANER CAP SUB-ASSEMBLY

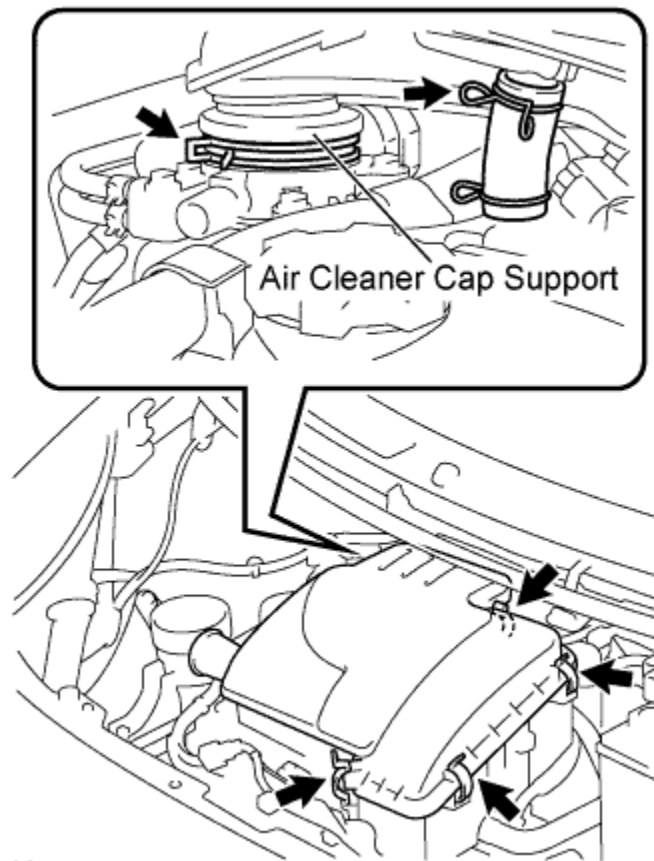

Y

1. Install the air cleaner cap with the 2 clamps.
2. Tighten the 4 clamps.

13. CONNECT CABLE TO NEGATIVE BATTERY TERMINAL

Torque:

5.4 N*m { 55 kgf*cm , 48 in.*lbf }

14. CHECK FOR ENGINE OIL LEAKAGE

CAMSHAFT > COMPONENTS

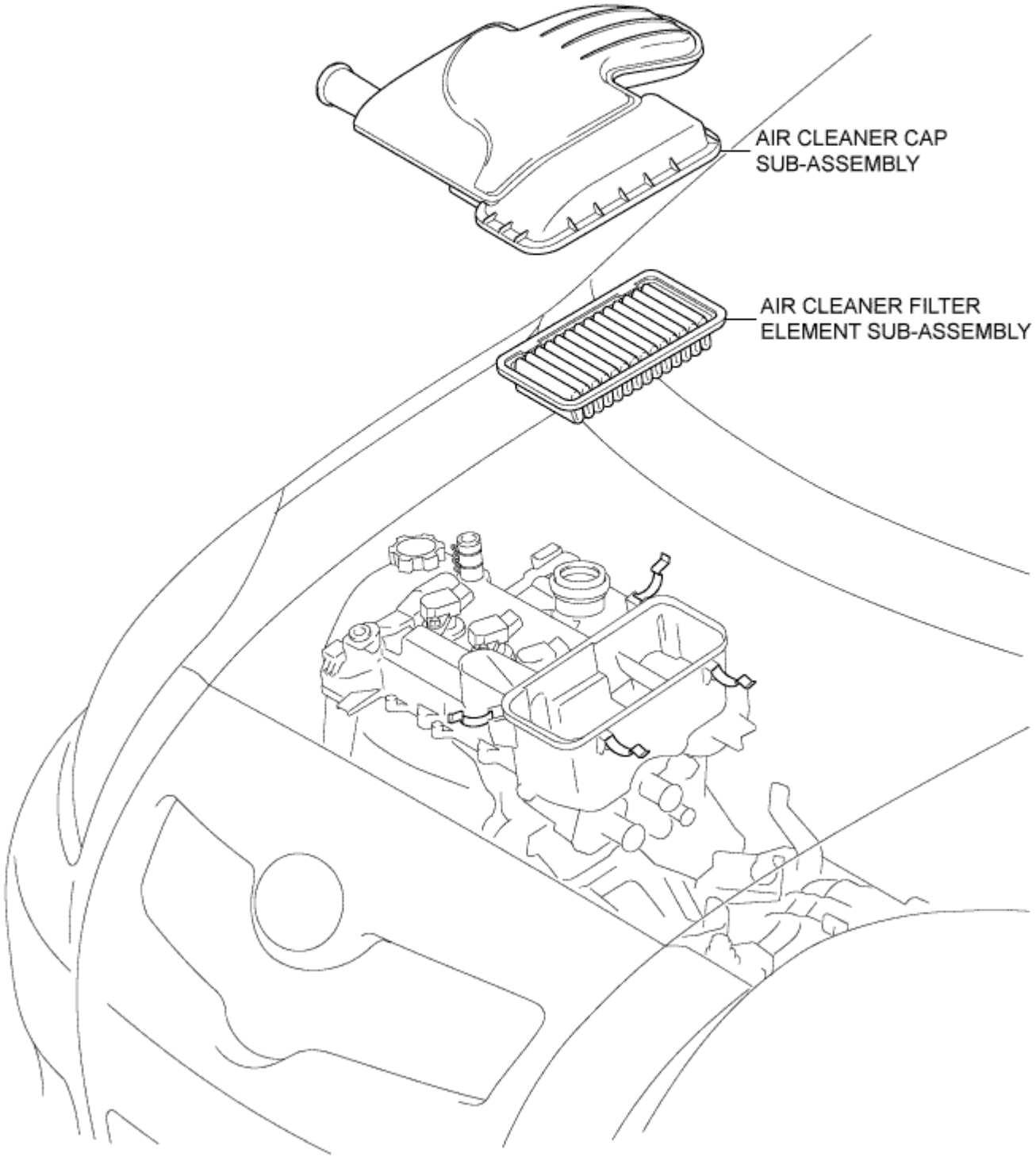

AIR CLEANER CAP
SUB-ASSEMBLY

AIR CLEANER FILTER
ELEMENT SUB-ASSEMBLY

1 / 2

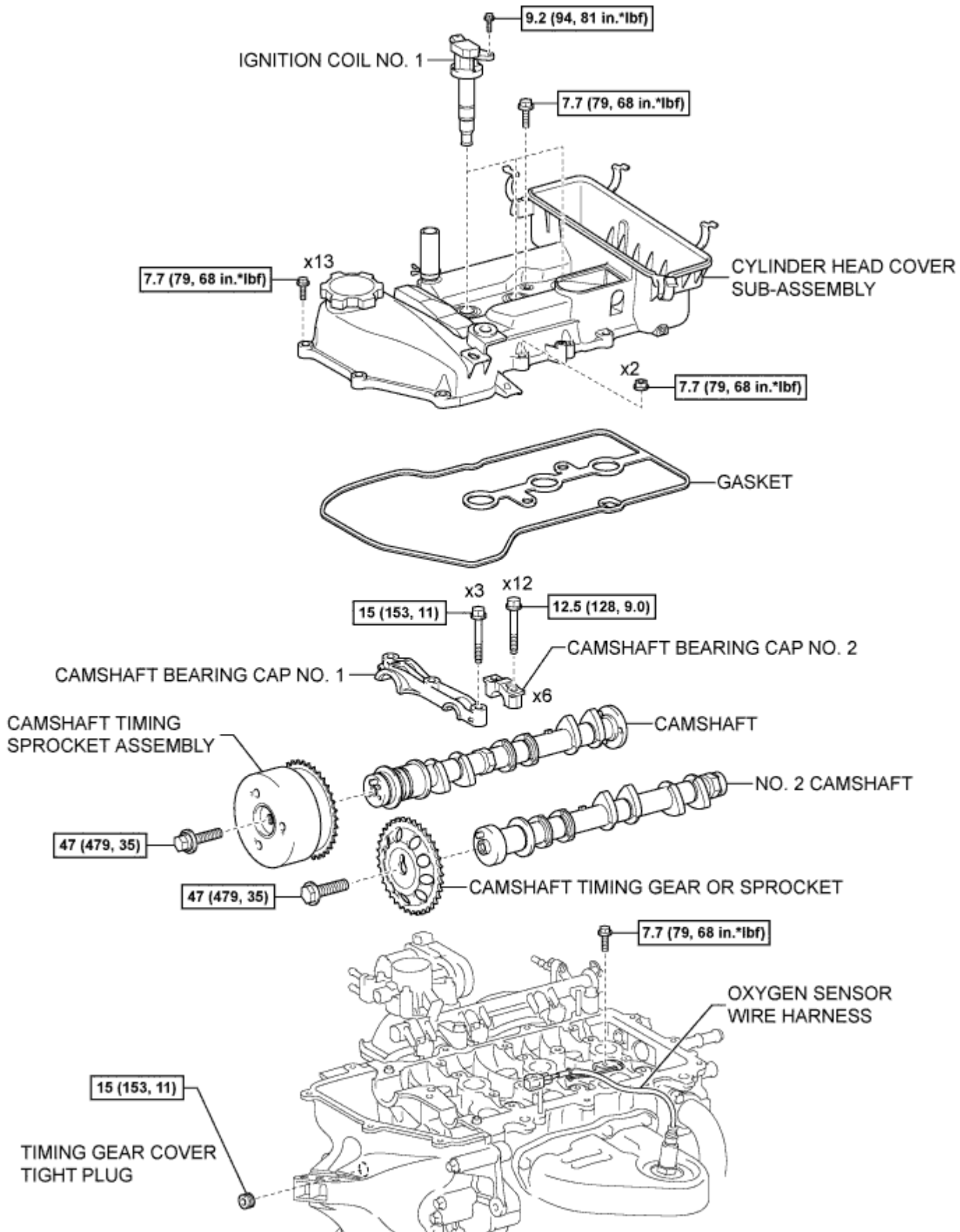

N*m (kgf*cm, ft.*lbf) : Specified torque

CAMSHAFT > REMOVAL

1. DISCONNECT CABLE FROM NEGATIVE BATTERY TERMINAL

2. REMOVE AIR CLEANER CAP SUB-ASSEMBLY

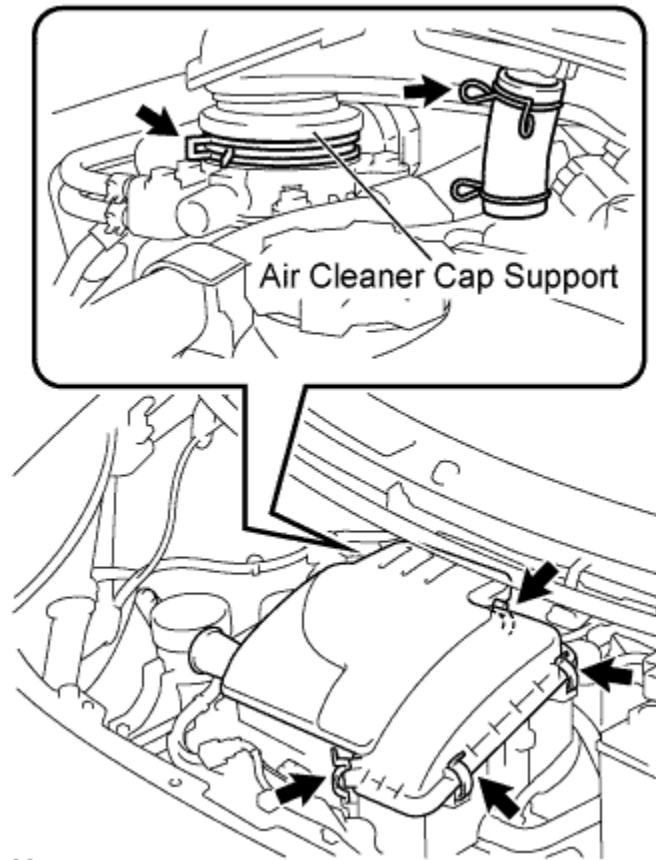

Y

1. Remove the 4 clamps.
2. Remove the 2 clamps and remove the air cleaner cap.

3. REMOVE AIR CLEANER FILTER ELEMENT SUB-ASSEMBLY

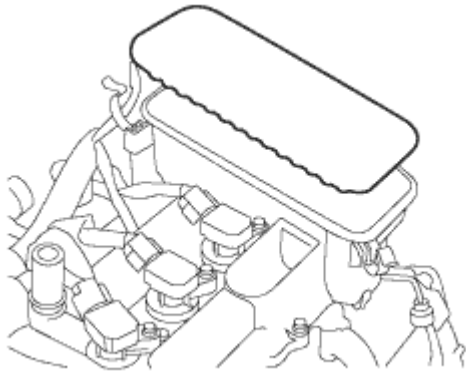

1. Remove the air cleaner filter element from the cylinder head cover.

4. REMOVE IGNITION COIL NO. 1

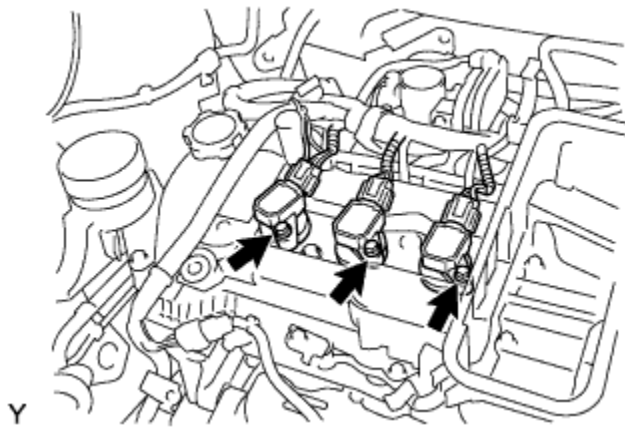

1. Disconnect the 3 ignition coil connectors.
2. Remove the 3 bolts and remove the 3 ignition coils.

5. REMOVE CYLINDER HEAD COVER SUB-ASSEMBLY

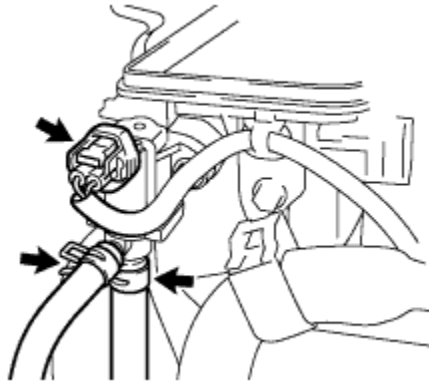

N

1. Disconnect the VSV connector and disengage the wire harness clamp.
2. Disconnect vapor feed hoses No. 1 and No. 2.

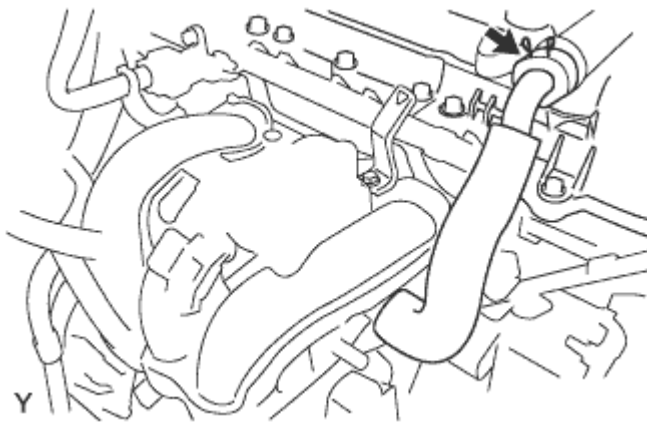

3. Disconnect the ventilation hose.

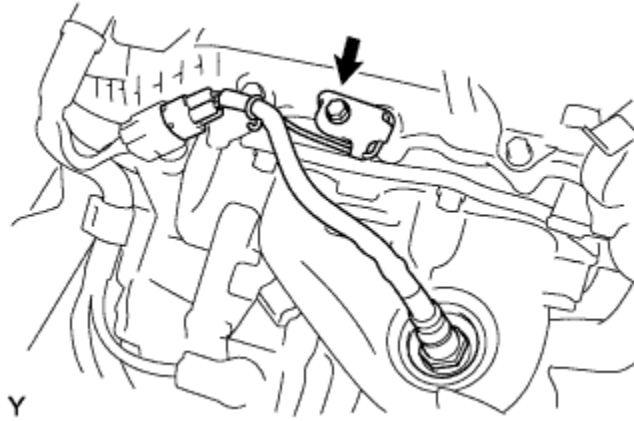

4. Remove the bolt and separate the oxygen sensor wire harness.
5. Separate the wire harness.

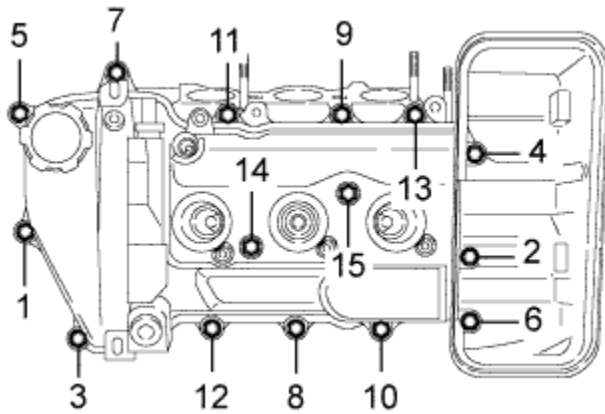

6. Remove the 13 bolts and 2 nuts in the order shown in the illustration and remove the cylinder head cover with the gasket.

6. REMOVE TIMING GEAR COVER TIGHT PLUG

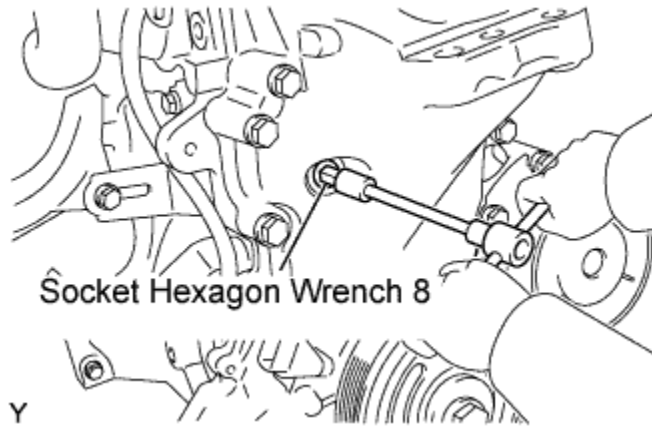

1. Using an 8mm socket hexagon wrench, remove the timing gear cover tight plug.

7. REMOVE CAMSHAFT TIMING GEAR OR SPROCKET

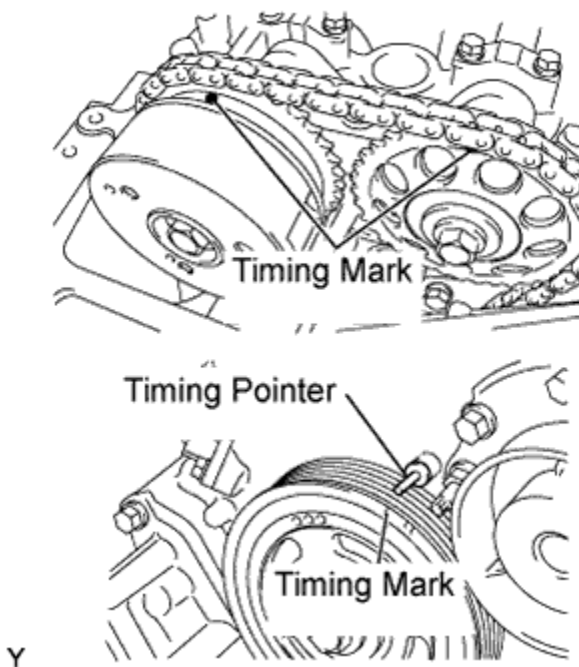

1. Turn the crankshaft pulley clockwise to align the timing mark on the pulley with the timing pointer of timing chain cover (Set the No. 1 piston to the TDC/compression).
2. Make sure that the timing mark of the camshaft sprocket is at the top.

HINT:

If the timing mark is not at the top, turn the crankshaft pulley 1 revolution so that the timing mark comes to the top (Set the No. 1 piston to the TDC/compression).

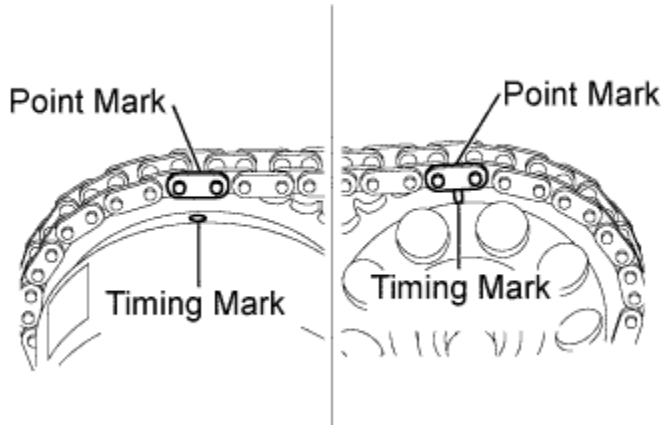

3. Put matchmarks on each plate of the timing chain where the plates are aligned with the matchmarks on the sprockets and camshaft timing sprocket (VVT controller). (*1)

HINT:

Omit step *1 if the orange mark plates are aligned with the cam sprockets, and the yellow mark plate is aligned with the crankshaft.

4. Turn the crankshaft pulley slightly counterclockwise.

NOTICE:

Do not allow the lifted valve and piston to come into contact with each other when removing the camshaft.

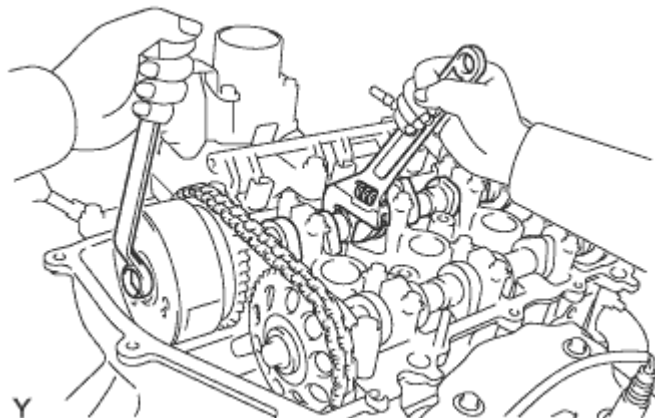

5. Loosen the bolts on the sprocket while holding the hexagonal portion of the camshaft.

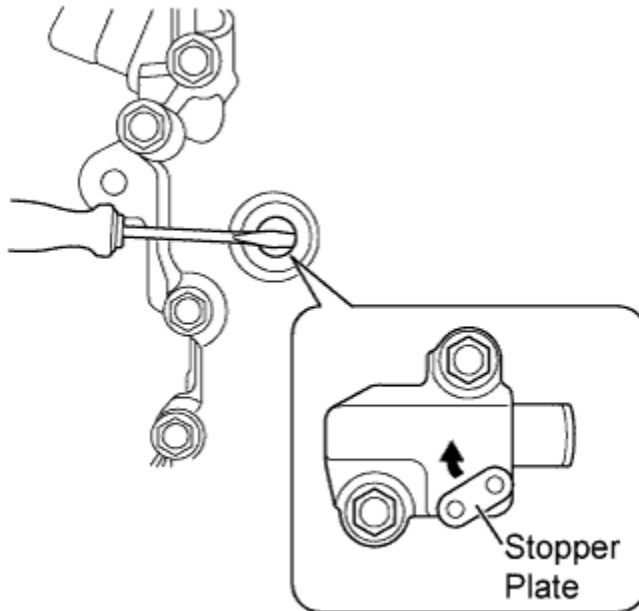

c

6. Insert a screwdriver from the plug hole and turn the stopper plate of the timing chain tensioner clockwise to release the lock, and keep it as it is.

HINT:

- The plunger of the timing chain tensioner is locked.
- If the stopper plate is locked firmly, slightly turn the hexagonal portion of the camshaft to the right and left.

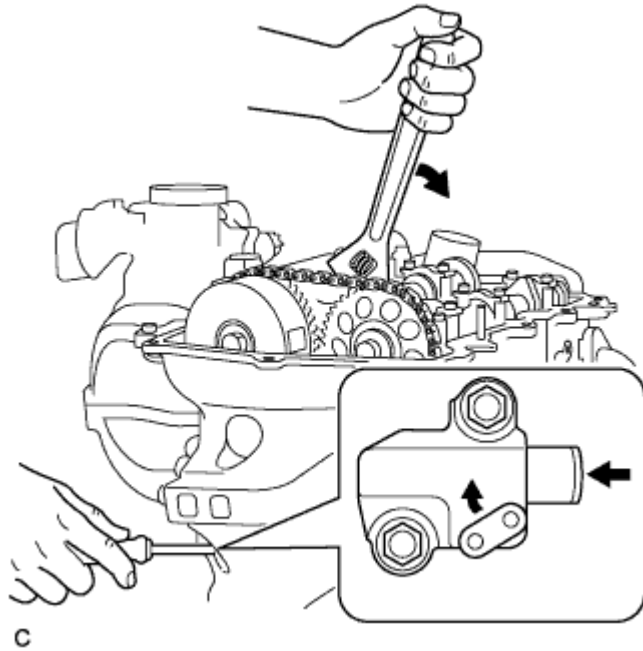

- c
7. Slightly turn the hexagonal portion of the camshaft clockwise so that the plunger of the timing chain tensioner is pushed by the timing chain.

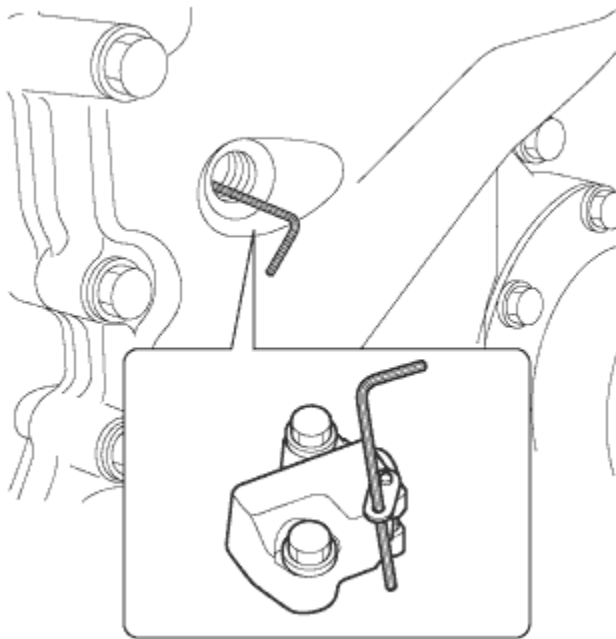

8. Remove the screwdriver from the plug. Insert the hexagon wrench into the stopper plate hole.

NOTICE:

Hold the hexagonal portion of the camshaft.

HINT:

Perform this procedure in order to maintain the pressure on the plunger from the timing chain tensioner.

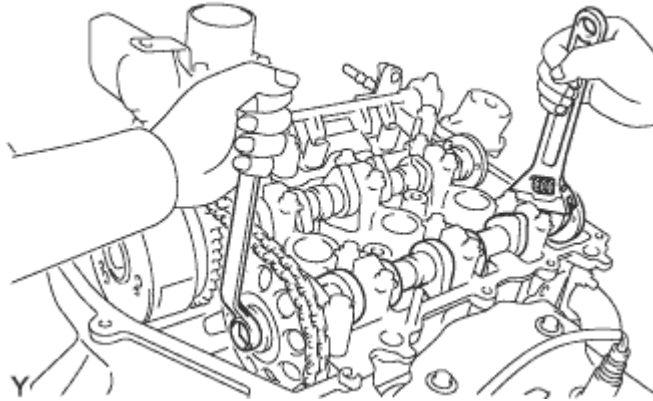

9. Remove the bolt of the sprocket while holding the hexagonal portion of camshaft No. 2.

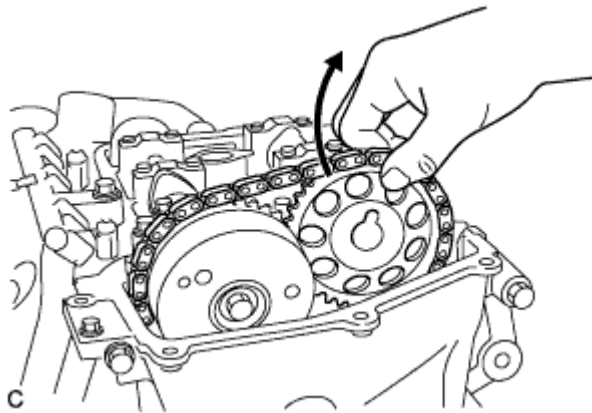

10. Remove the camshaft timing gear.

8. REMOVE NO. 2 CAMSHAFT

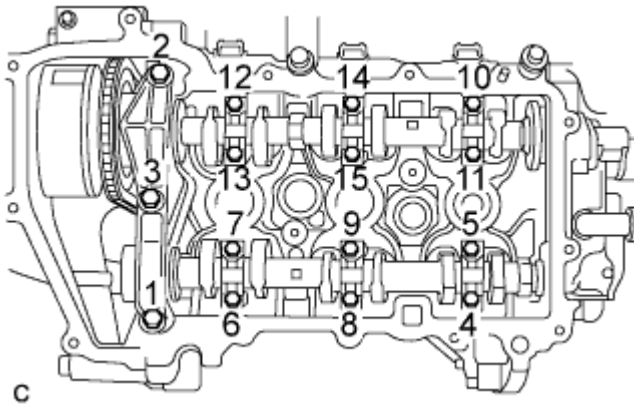

1. Remove the 15 bolts in the order shown in the illustration.

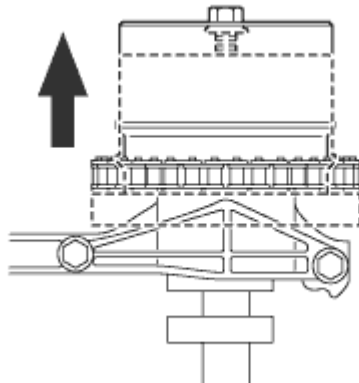

Y

2. Slide the camshaft timing sprocket toward the engine front until camshaft bearing cap No. 1 comes off.
3. Remove camshaft bearing caps No. 1 and No. 2.
4. Remove camshaft No. 2.

9. REMOVE CAMSHAFT

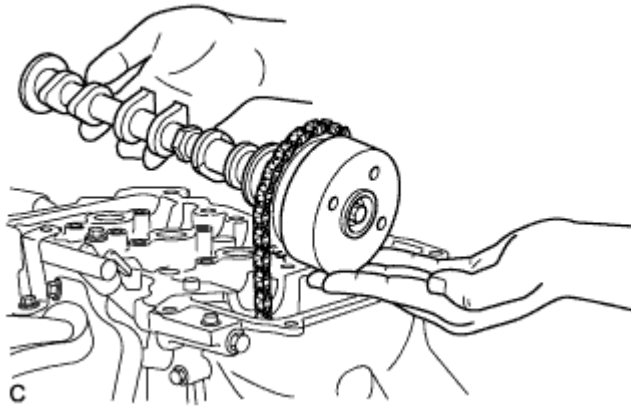

1. Remove camshaft assembly No. 1 .

HINT:

- Remove camshaft assembly No. 1 along with the camshaft timing sprocket.
- Assemble the camshaft timing sprocket to camshaft assembly No. 1 before installing them.

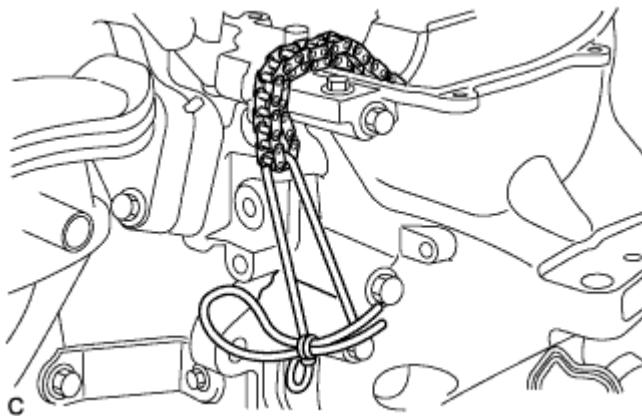

2. Using a piece of string or the equivalent, fix the timing chain to prevent it from dropping.

CAMSHAFT > INSPECTION

1. INSPECT CAMSHAFT TIMING SPROCKET ASSEMBLY

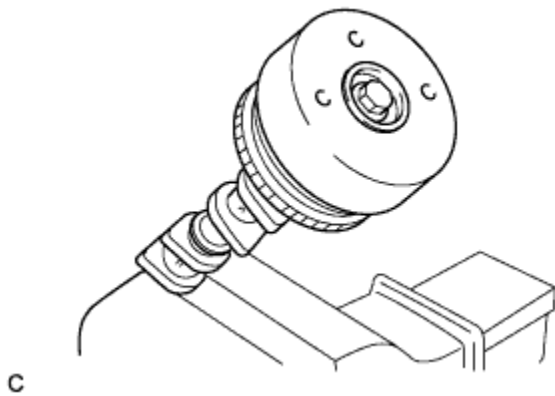

1. Hold the hexagonal portion of camshaft assembly No. 1 in a vise.

NOTICE:

Do not disassemble the camshaft timing sprocket assembly (VVT controller).

2. Tighten the bolts of the camshaft timing sprocket assembly to the specified torque.

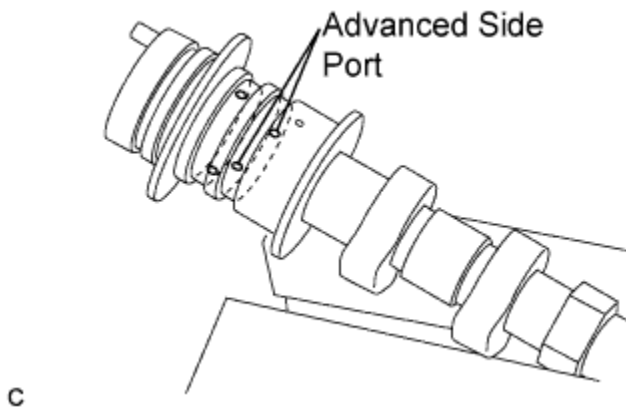

3. Plug either of the advanced side port of camshaft assembly No. 1 with your finger or tape.

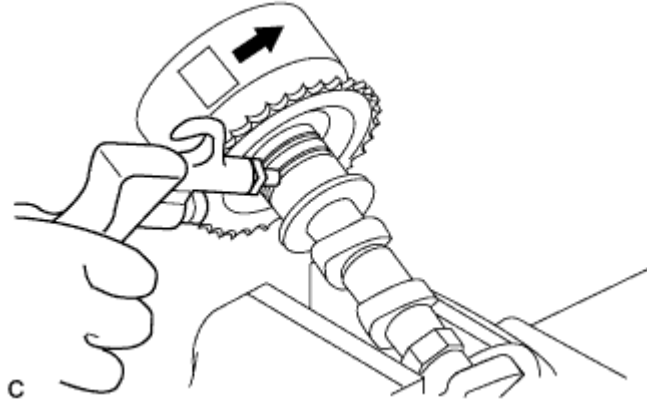

4. Apply pressure to the other advanced side path.

NOTICE:

Cover the paths to prevent oil from splashing.

HINT:

The lock for the most retarded position will be released.

5. Make sure that the lock for the most retarded position of the camshaft timing sprocket is released and the sprocket can be moved smoothly within the movable range by hand.

NOTICE:

The camshaft timing sprocket will be locked if it is turned to the most retarded position.

6. Lock the camshaft timing sprocket in the most retarded position.

CAMSHAFT > INSTALLATION

1. INSTALL CAMSHAFT

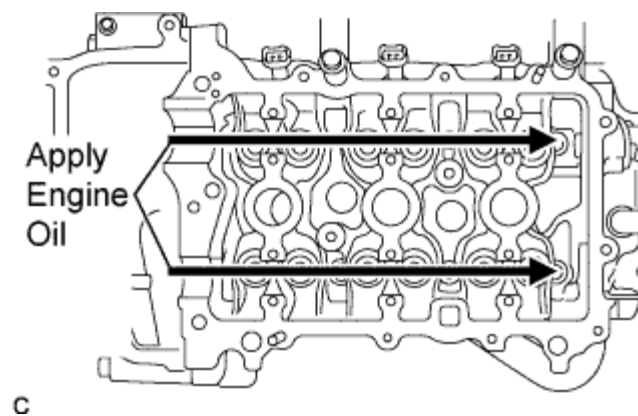

1. Apply engine oil to the cam of each camshaft, the journals of the cylinder head and the top of each valve lifter.

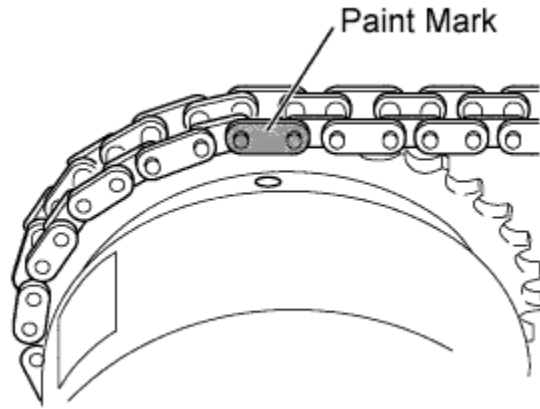

2. Align the matchmarks on the timing chain plates with the timing mark of the camshaft timing sprocket (VVT controller) and the paint mark of the timing chain respectively and install the timing chain.

2. INSTALL NO.2 CAMSHAFT

1. Apply engine oil to the cam of each camshaft No. 2.

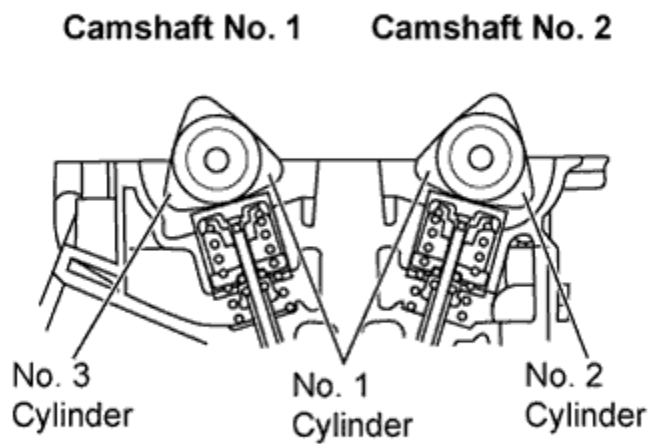

2. Install the camshafts as shown in the illustration.

HINT:

Make sure that the timing marks of the camshaft timing sprocket and camshaft timing sprocket (VVT controller) face upward.

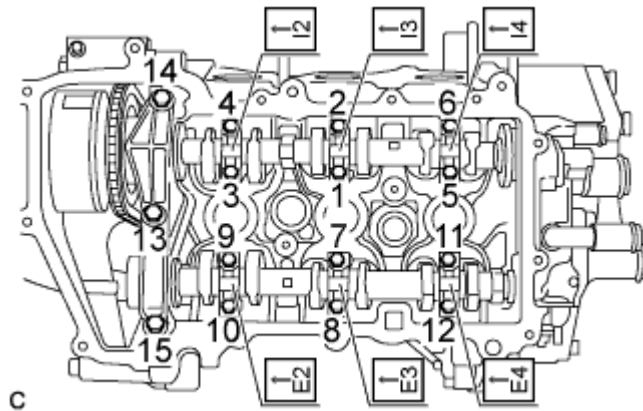

3. Place camshaft bearing caps No. 1 and No. 2 and tighten the bolts to the specified torque in the order shown in the illustration.

Torque:

Camshaft bearing cap No. 1:
15 N*m { 153 kgf*cm , 11 ft.*lbf }

Camshaft bearing cap No. 2:
12.5 N*m { 128 kgf*cm , 9 ft.*lbf }

NOTICE:

Install camshaft bearing caps No. 1 and No. 2 with the front marks facing engine front.

3. INSTALL CAMSHAFT TIMING GEAR OR SPROCKET

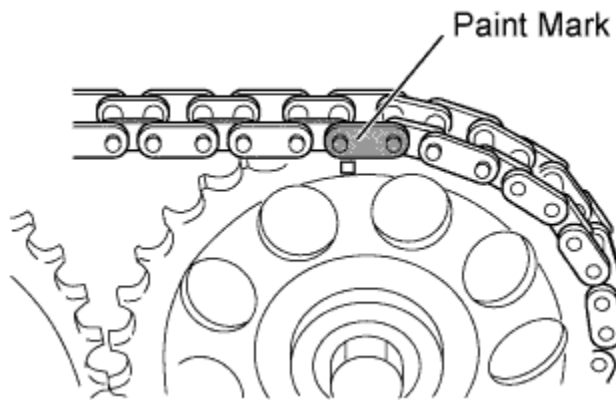

1. Align the matchmarks on the timing chain plates with the timing mark of the camshaft timing gear and the paint mark of the timing chain respectively and install the timing chain.

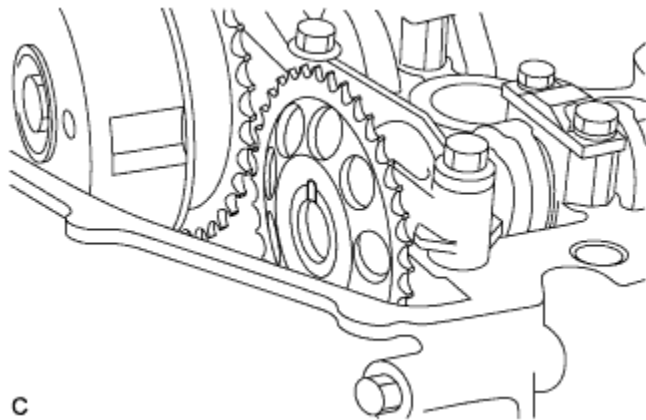

2. Install camshaft No. 2 with the knock pin aligned with the gear groove.

HINT:

Position the matchmark of the gear at the top.

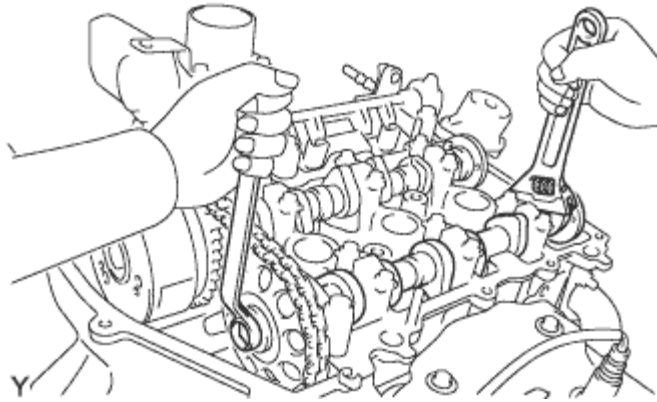

3. Tighten the bolts onto the timing gear while holding the hexagonal portion of the camshaft No. 2.

Torque:
47 N*m { 479 kgf*cm , 35 ft.*lbf }

4. INSTALL CAMSHAFT TIMING SPROCKET ASSEMBLY

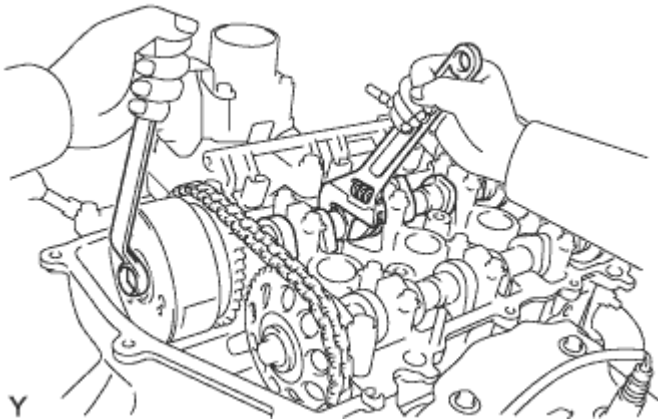

1. Tighten the bolts onto the sprocket while holding the hexagonal portion of the camshaft.

Torque:
47 N*m { 479 kgf*cm , 35 ft.*lbf }

5. INSTALL TIMING GEAR COVER TIGHT PLUG

1. Remove the hexagon wrench from the timing chain tensioner sub-assembly.

HINT:

Before removing, slightly turn the hexagonal portion of the camshaft assembly counterclockwise to leave some slack on the chain of the timing chain tensioner sub-assembly side.

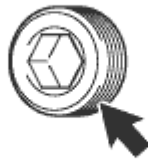

Y

2. Clean the plug and the bolt holes of the timing chain cover and apply adhesive to the threads of the plug.

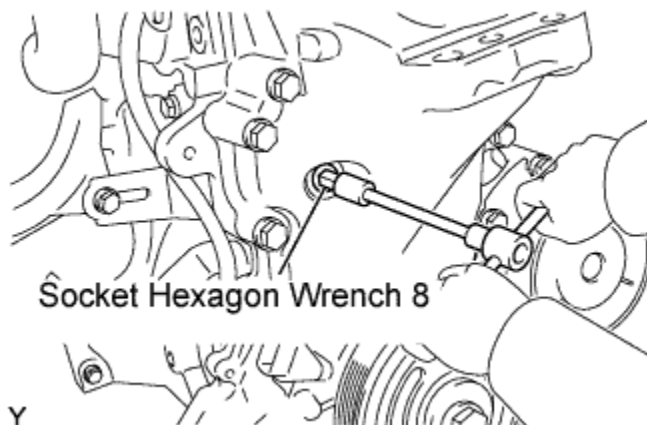

3. Using an 8mm socket hexagon wrench, install timing gear tight plug No. 1.

Torque:

15 N*m { 153 kgf*cm , 11 ft.*lbf }

6. INSPECT VALVE CLEARANCE

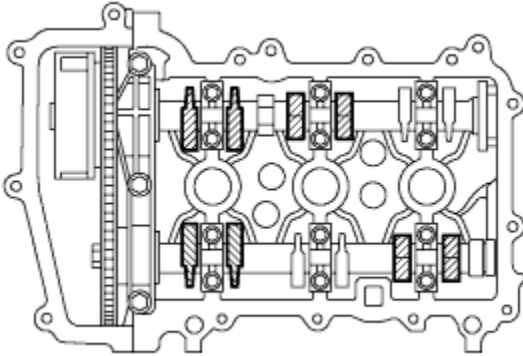

N

1. Check only the valves indicated.
 1. Using a feeler gauge, measure the clearance between the valve lifter and camshaft.

Valve clearance (Cold):
Intake side:
0.145 to 0.235 mm (0.00571 to 0.00925 in.)
Exhaust side:
0.275 to 0.365 mm (0.01083 to 0.01437 in.)
HINT:
Insert the feeler gauge from the spark plug side (center).
 2. Record any out-of-specification valve clearance measurements. They will be used later to determine the required replacement valve lifters.
2. Turn the crankshaft 1 revolution (360°).

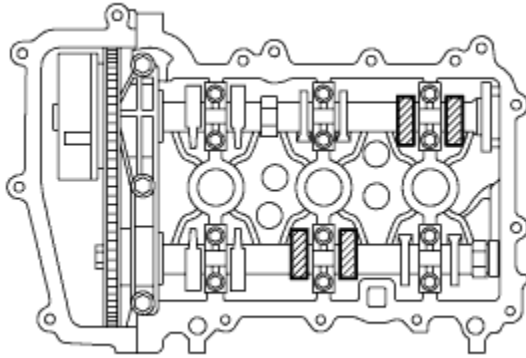

N

3. Check only the valves indicated.
 1. Using a feeler gauge, measure the clearance between the valve lifter and camshaft.

Valve clearance (Cold):

Intake side:

0.145 to 0.235 mm (0.00571 to 0.00925 in.)

Exhaust side:

0.275 to 0.365 mm (0.01083 to 0.01437 in.)

HINT:

Insert the feeler gauge from the spark plug side (center).

2. Record any out-of-specification valve clearance measurements. They will be used later to determine the required replacement valve lifters.

7. ADJUST VALVE CLEARANCE

1. Remove the No. 1 and No. 2 camshafts ().
2. Remove the valve lifters ().

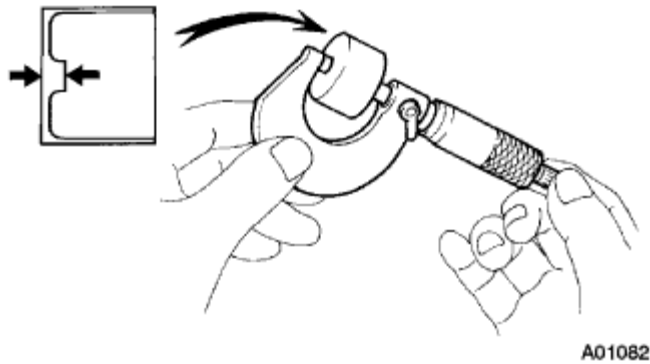

3. Using a micrometer, measure the thickness of the removed valve lifters.
4. Calculate the thickness of a new lifter so that the valve clearance comes within the specified value.

| | |
|---|--------------------------|
| A | Thickness of new lifter |
| B | Thickness of used lifter |
| C | Measured valve clearance |

5. Valve clearance:
6. Intake $A = B + (C - 0.18 \text{ mm (0.0071 in.)})$
7. Exhaust $A = B + (C - 0.31 \text{ mm (0.0122 in.)})$
8. HINT:
 - Select a new lifter with a thickness as close to the calculated values as possible.
 - Lifters are available in 29 sizes in increments of 0.020 mm (0.0008 in.), from 5.12 mm (0.2016 in.) to 5.68 mm (0.2236 in.).
 - Refer to the New Lifter Thickness Table on the next 2 pages.
5. Install the valve lifters ().

6. Install the No. 1 and No. 2 camshafts ().

Valve Lifter Selection Chart (Intake)

| Measured Clearance mm (in.) | Installed Lifter Thickness mm (in.) | | | | | | | | | | | | | | | | |
|---------------------------------|--|----|----|----|----|----|----|----|----|----|----|----|----|----|----|----|----------------|
| | | 18 | 20 | 22 | 24 | 26 | 28 | 30 | 32 | 34 | 36 | 38 | 40 | 42 | 44 | 46 | |
| 0.000 - 0.030 (0.0000 - 0.0012) | | | | | | | | | | | | | | | | | 5.120 (0.2016) |
| 0.031 - 0.050 (0.0012 - 0.0020) | | | | | | | | | | | | | | | | | 5.140 (0.2024) |
| 0.051 - 0.070 (0.0020 - 0.0028) | | | | | | | | | | | | | | | | | 5.160 (0.2031) |
| 0.071 - 0.090 (0.0028 - 0.0035) | | | | | | | | | | | | | | | | | 5.180 (0.2039) |
| 0.091 - 0.110 (0.0036 - 0.0043) | | | | | | | | | | | | | | | | | 5.200 (0.2047) |
| 0.111 - 0.130 (0.0044 - 0.0051) | | | | | | | | | | | | | | | | | 5.210 (0.2051) |
| 0.131 - 0.149 (0.0052 - 0.0059) | | | | | | | | | | | | | | | | | 5.220 (0.2055) |
| 0.150 - 0.250 (0.0059 - 0.0098) | | | | | | | | | | | | | | | | | 5.230 (0.2059) |
| 0.251 - 0.270 (0.0099 - 0.0106) | | | | | | | | | | | | | | | | | 5.240 (0.2063) |
| 0.271 - 0.290 (0.0107 - 0.0114) | | | | | | | | | | | | | | | | | 5.250 (0.2067) |
| 0.291 - 0.310 (0.0115 - 0.0122) | | | | | | | | | | | | | | | | | 5.260 (0.2071) |
| 0.311 - 0.330 (0.0122 - 0.0130) | | | | | | | | | | | | | | | | | 5.270 (0.2075) |
| 0.331 - 0.350 (0.0130 - 0.0138) | | | | | | | | | | | | | | | | | 5.280 (0.2079) |
| 0.351 - 0.370 (0.0138 - 0.0146) | | | | | | | | | | | | | | | | | 5.290 (0.2083) |
| 0.371 - 0.390 (0.0146 - 0.0154) | | | | | | | | | | | | | | | | | 5.300 (0.2087) |
| 0.391 - 0.410 (0.0154 - 0.0161) | | | | | | | | | | | | | | | | | 5.310 (0.2091) |
| 0.411 - 0.430 (0.0162 - 0.0169) | | | | | | | | | | | | | | | | | 5.320 (0.2094) |
| 0.431 - 0.450 (0.0170 - 0.0177) | | | | | | | | | | | | | | | | | 5.330 (0.2098) |
| 0.451 - 0.470 (0.0178 - 0.0185) | | | | | | | | | | | | | | | | | 5.340 (0.2102) |
| 0.471 - 0.490 (0.0185 - 0.0193) | | | | | | | | | | | | | | | | | 5.350 (0.2106) |
| 0.491 - 0.510 (0.0193 - 0.0201) | | | | | | | | | | | | | | | | | 5.360 (0.2110) |
| 0.511 - 0.530 (0.0201 - 0.0209) | | | | | | | | | | | | | | | | | 5.370 (0.2114) |
| 0.531 - 0.550 (0.0209 - 0.0217) | | | | | | | | | | | | | | | | | 5.380 (0.2118) |
| 0.551 - 0.570 (0.0217 - 0.0224) | | | | | | | | | | | | | | | | | 5.390 (0.2122) |
| 0.571 - 0.590 (0.0225 - 0.0232) | | | | | | | | | | | | | | | | | 5.400 (0.2126) |
| 0.591 - 0.610 (0.0233 - 0.0240) | | | | | | | | | | | | | | | | | 5.410 (0.2130) |
| 0.611 - 0.630 (0.0241 - 0.0248) | | | | | | | | | | | | | | | | | 5.420 (0.2134) |
| 0.631 - 0.650 (0.0248 - 0.0256) | | | | | | | | | | | | | | | | | 5.430 (0.2138) |
| 0.651 - 0.670 (0.0256 - 0.0264) | | | | | | | | | | | | | | | | | 5.440 (0.2142) |
| 0.671 - 0.690 (0.0264 - 0.0272) | | | | | | | | | | | | | | | | | 5.450 (0.2146) |
| 0.691 - 0.710 (0.0272 - 0.0280) | | | | | | | | | | | | | | | | | 5.460 (0.2150) |
| 0.711 - 0.730 (0.0280 - 0.0287) | | | | | | | | | | | | | | | | | 5.470 (0.2154) |
| 0.731 - 0.750 (0.0288 - 0.0295) | | | | | | | | | | | | | | | | | 5.480 (0.2157) |
| 0.751 - 0.770 (0.0296 - 0.0303) | | | | | | | | | | | | | | | | | 5.490 (0.2161) |
| | | | | | | | | | | | | | | | | | 5.500 (0.2165) |
| | | | | | | | | | | | | | | | | | 5.510 (0.2169) |
| | | | | | | | | | | | | | | | | | 5.520 (0.2173) |
| | | | | | | | | | | | | | | | | | 5.530 (0.2177) |
| | | | | | | | | | | | | | | | | | 5.540 (0.2181) |
| | | | | | | | | | | | | | | | | | 5.550 (0.2185) |
| | | | | | | | | | | | | | | | | | 5.560 (0.2189) |
| | | | | | | | | | | | | | | | | | 5.570 (0.2193) |
| | | | | | | | | | | | | | | | | | 5.580 (0.2197) |
| | | | | | | | | | | | | | | | | | 5.590 (0.2201) |
| | | | | | | | | | | | | | | | | | 5.600 (0.2205) |
| | | | | | | | | | | | | | | | | | 5.620 (0.2213) |
| | | | | | | | | | | | | | | | | | 5.640 (0.2220) |
| | | | | | | | | | | | | | | | | | 5.660 (0.2228) |
| | | | | | | | | | | | | | | | | | 5.680 (0.2236) |

Valve Lifter Selection Chart (Exhaust)

| | | Measured Clearance mm (in.) | Installed Lifter Thickness mm (in.) |
|--|--|---------------------------------|--|
| | | 0.000 - 0.030 (0.0000 - 0.0012) | 5.120 (0.2018) |
| | | 0.031 - 0.050 (0.0012 - 0.0020) | 5.140 (0.2024) |
| | | 0.051 - 0.070 (0.0020 - 0.0028) | 5.160 (0.2031) |
| | | 0.071 - 0.090 (0.0028 - 0.0035) | 5.180 (0.2039) |
| | | 0.091 - 0.110 (0.0035 - 0.0043) | 5.200 (0.2047) |
| | | 0.111 - 0.130 (0.0043 - 0.0051) | 5.220 (0.2055) |
| | | 0.131 - 0.150 (0.0052 - 0.0059) | 5.230 (0.2059) |
| | | 0.151 - 0.170 (0.0059 - 0.0067) | 5.240 (0.2063) |
| | | 0.171 - 0.190 (0.0067 - 0.0075) | 5.250 (0.2067) |
| | | 0.191 - 0.210 (0.0075 - 0.0083) | 5.260 (0.2071) |
| | | 0.211 - 0.230 (0.0083 - 0.0091) | 5.270 (0.2075) |
| | | 0.231 - 0.249 (0.0091 - 0.0098) | 5.280 (0.2079) |
| | | 0.250 - 0.269 (0.0098 - 0.0106) | 5.290 (0.2083) |
| | | 0.269 - 0.287 (0.0106 - 0.0114) | 5.300 (0.2087) |
| | | 0.288 - 0.306 (0.0114 - 0.0122) | 5.310 (0.2091) |
| | | 0.307 - 0.325 (0.0122 - 0.0130) | 5.320 (0.2094) |
| | | 0.326 - 0.344 (0.0130 - 0.0138) | 5.330 (0.2098) |
| | | 0.345 - 0.363 (0.0138 - 0.0146) | 5.340 (0.2102) |
| | | 0.364 - 0.382 (0.0146 - 0.0154) | 5.350 (0.2106) |
| | | 0.383 - 0.401 (0.0154 - 0.0162) | 5.360 (0.2110) |
| | | 0.402 - 0.420 (0.0162 - 0.0169) | 5.370 (0.2114) |
| | | 0.421 - 0.439 (0.0169 - 0.0177) | 5.380 (0.2118) |
| | | 0.440 - 0.458 (0.0177 - 0.0185) | 5.390 (0.2122) |
| | | 0.459 - 0.477 (0.0185 - 0.0193) | 5.400 (0.2126) |
| | | 0.478 - 0.496 (0.0193 - 0.0201) | 5.410 (0.2130) |
| | | 0.497 - 0.515 (0.0201 - 0.0209) | 5.420 (0.2134) |
| | | 0.516 - 0.534 (0.0209 - 0.0217) | 5.430 (0.2138) |
| | | 0.535 - 0.553 (0.0217 - 0.0224) | 5.440 (0.2142) |
| | | 0.554 - 0.572 (0.0224 - 0.0232) | 5.450 (0.2146) |
| | | 0.573 - 0.591 (0.0232 - 0.0240) | 5.460 (0.2150) |
| | | 0.592 - 0.610 (0.0240 - 0.0248) | 5.470 (0.2154) |
| | | 0.611 - 0.629 (0.0248 - 0.0256) | 5.480 (0.2157) |
| | | 0.630 - 0.648 (0.0256 - 0.0264) | 5.490 (0.2161) |
| | | 0.649 - 0.667 (0.0264 - 0.0272) | 5.500 (0.2165) |
| | | 0.668 - 0.686 (0.0272 - 0.0280) | 5.510 (0.2169) |
| | | 0.687 - 0.705 (0.0280 - 0.0287) | 5.520 (0.2173) |
| | | 0.706 - 0.724 (0.0287 - 0.0295) | 5.530 (0.2177) |
| | | 0.725 - 0.743 (0.0295 - 0.0303) | 5.540 (0.2181) |
| | | 0.744 - 0.762 (0.0303 - 0.0311) | 5.550 (0.2185) |
| | | 0.763 - 0.781 (0.0311 - 0.0319) | 5.560 (0.2189) |
| | | 0.782 - 0.800 (0.0319 - 0.0327) | 5.570 (0.2193) |
| | | 0.801 - 0.819 (0.0327 - 0.0335) | 5.580 (0.2197) |
| | | 0.820 - 0.838 (0.0335 - 0.0343) | 5.590 (0.2201) |
| | | | 5.600 (0.2205) |
| | | | 5.620 (0.2213) |
| | | | 5.640 (0.2220) |
| | | | 5.660 (0.2228) |
| | | | 5.680 (0.2236) |

HINT:

| New lifter thickness mm (in.) | | | | | |
|-------------------------------|---------------|------------|---------------|------------|---------------|
| Lifter No. | Thickness | Lifter No. | Thickness | Lifter No. | Thickness |
| 12 | 5.12 (0.2016) | 32 | 5.32 (0.2094) | 52 | 5.52 (0.2173) |
| 14 | 5.14 (0.2024) | 34 | 5.34 (0.2102) | 54 | 5.54 (0.2181) |
| 16 | 5.16 (0.2031) | 36 | 5.36 (0.2110) | 56 | 5.56 (0.2189) |
| 18 | 5.18 (0.2039) | 38 | 5.38 (0.2118) | 58 | 5.58 (0.2197) |
| 20 | 5.20 (0.2047) | 40 | 5.40 (0.2126) | 60 | 5.60 (0.2205) |
| 22 | 5.22 (0.2055) | 42 | 5.42 (0.2134) | 62 | 5.62 (0.2213) |
| 24 | 5.24 (0.2063) | 44 | 5.44 (0.2142) | 64 | 5.64 (0.2220) |
| 26 | 5.26 (0.2071) | 46 | 5.46 (0.2150) | 66 | 5.66 (0.2228) |
| 28 | 5.28 (0.2079) | 48 | 5.48 (0.2157) | 68 | 5.68 (0.2236) |
| 30 | 5.30 (0.2087) | 50 | 5.50 (0.2165) | - | - |

8. INSTALL CYLINDER HEAD COVER SUB-ASSEMBLY

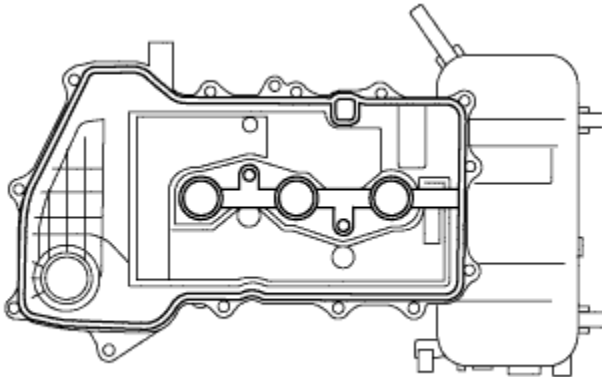

Y

1. Clean the cylinder head cover, cylinder head assembly and timing chain cover assembly.
2. Fit the cylinder head cover gasket into the gasket groove on the cover and onto the center bosses.

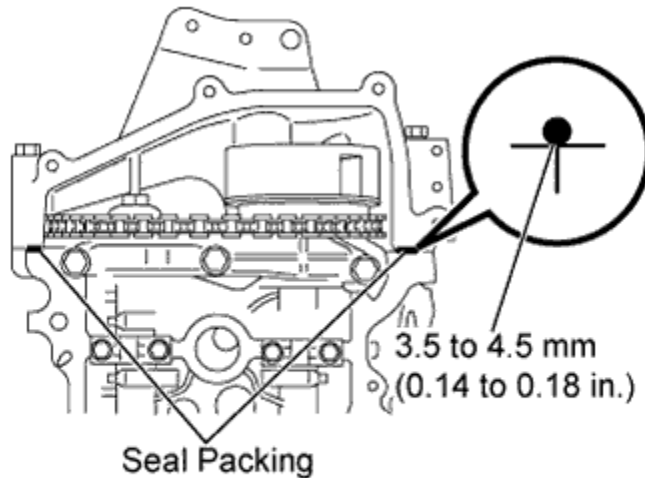

3. Apply a continuous bead of seal packing (diameter: 3.5 to 4.5 mm (0.14 to 0.18 in.)) to the contact surface between the cylinder head assembly and timing chain cover assembly, as shown in the illustration.

Seal Packing:

Part No. 08826-00080 or the equivalent

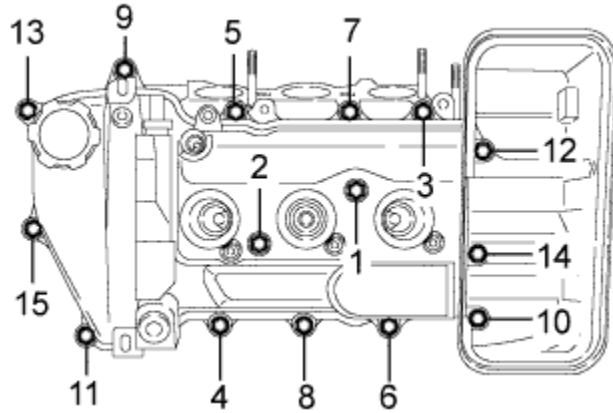

4. Install the bolts within 3 minutes of applying seal packing in the order shown in the illustration.

Torque:

7.7 N*m { 79 kgf*cm , 68 in.*lbf }

5. Tighten the bolts to the specified torque and make sure that bolts 1 and 2 are tightened to the specified torque shown in the illustration.
6. Install the wire harness.

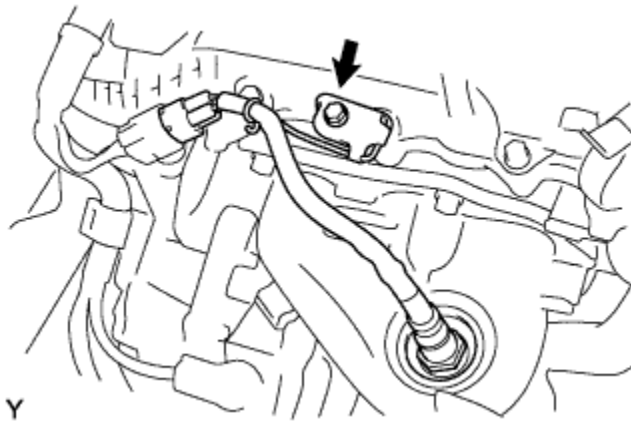

7. Install the oxygen sensor wire harness with the bolt.

Torque:

7.7 N*m { 79 kgf*cm , 68 in.*lbf }

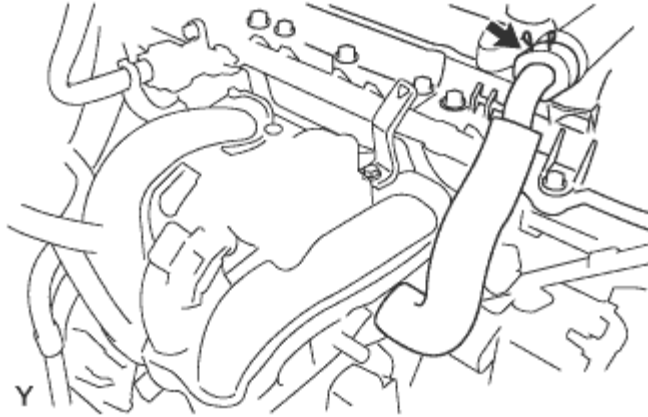

8. Connect the ventilation hose.

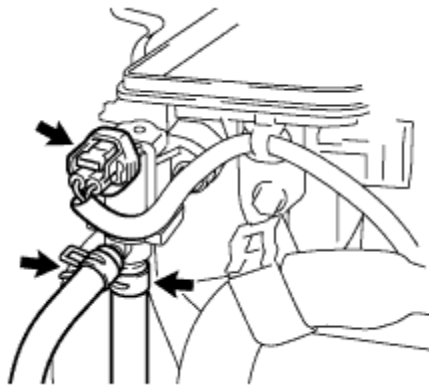

9. Connect vapor hoses No. 1 and No. 2.

10. Connect the VSV connector.

9. INSTALL IGNITION COIL NO. 1

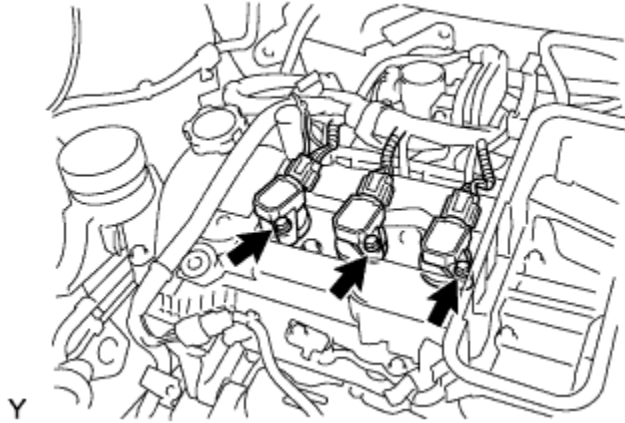

1. Install the 3 ignition coils with the 3 bolts.

Torque:

9.2 N*m { 94 kgf*cm , 81 in.*lbf }

2. Connect the ignition coil connectors.

10. INSTALL AIR CLEANER FILTER ELEMENT SUB-ASSEMBLY

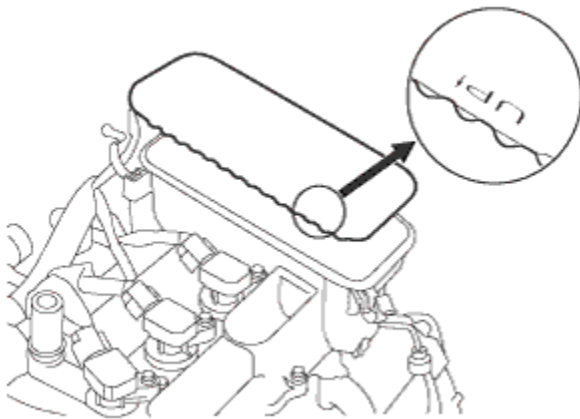

1. Install the air cleaner filter element as shown in the illustration.

11. INSTALL AIR CLEANER CAP SUB-ASSEMBLY

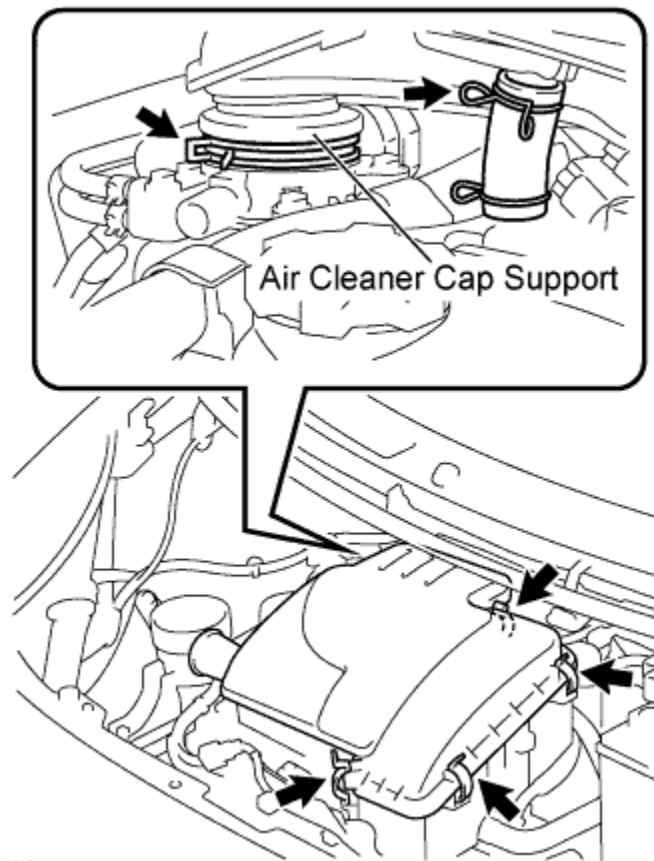

Y

1. Install the air cleaner cap with the 2 clamps.
2. Tighten the 4 clamps.

12. CONNECT CABLE TO NEGATIVE BATTERY TERMINAL

Torque:

5.4 N*m { 55 kgf*cm , 48 in.*lbf }

13. CHECK FOR ENGINE OIL LEAKAGE

**ENGINE ASSEMBLY >
COMPONENTS**

for LHD:

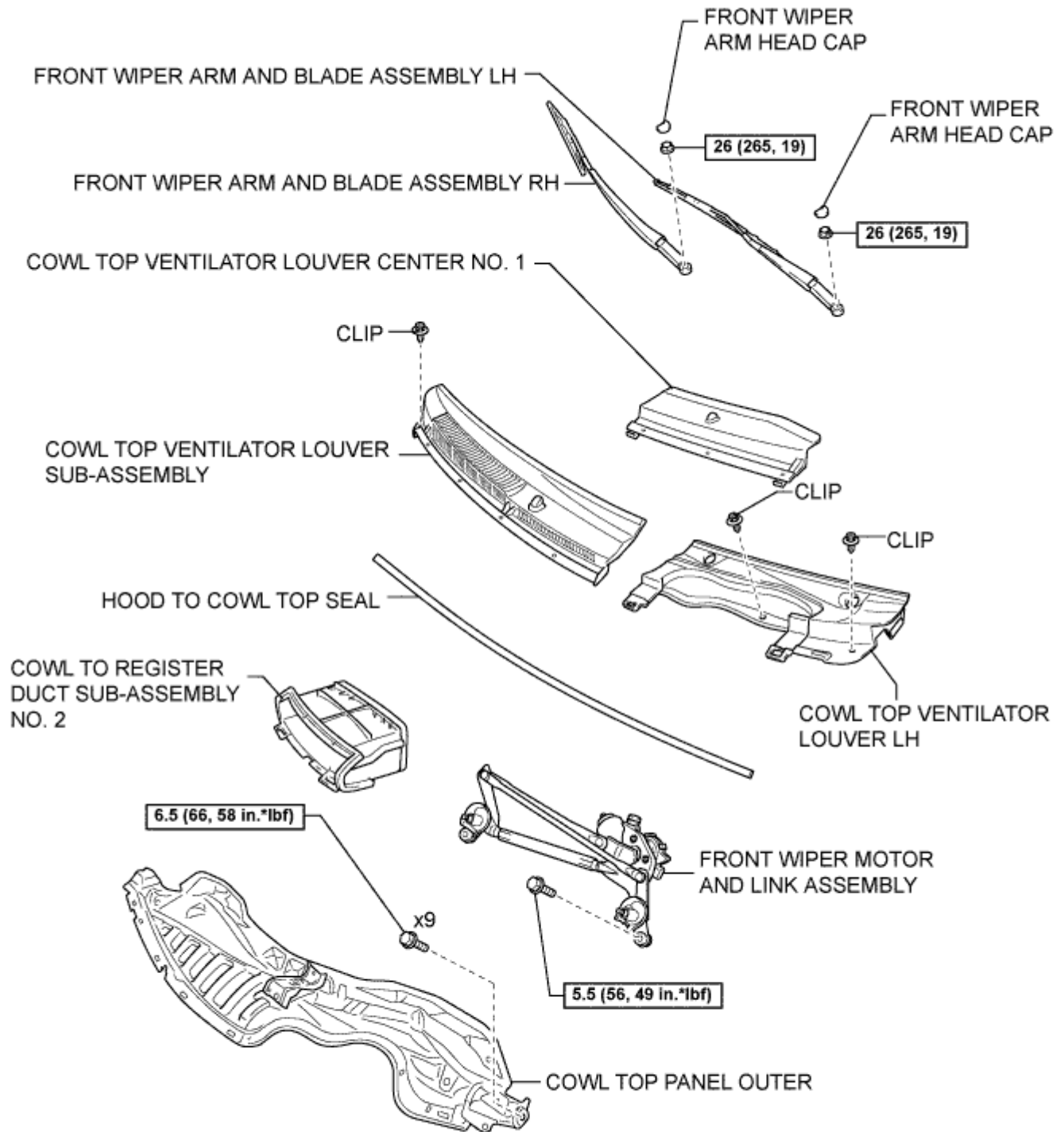

N*m (kgf*cm, ft*lbf) : Specified torque

for RHD:

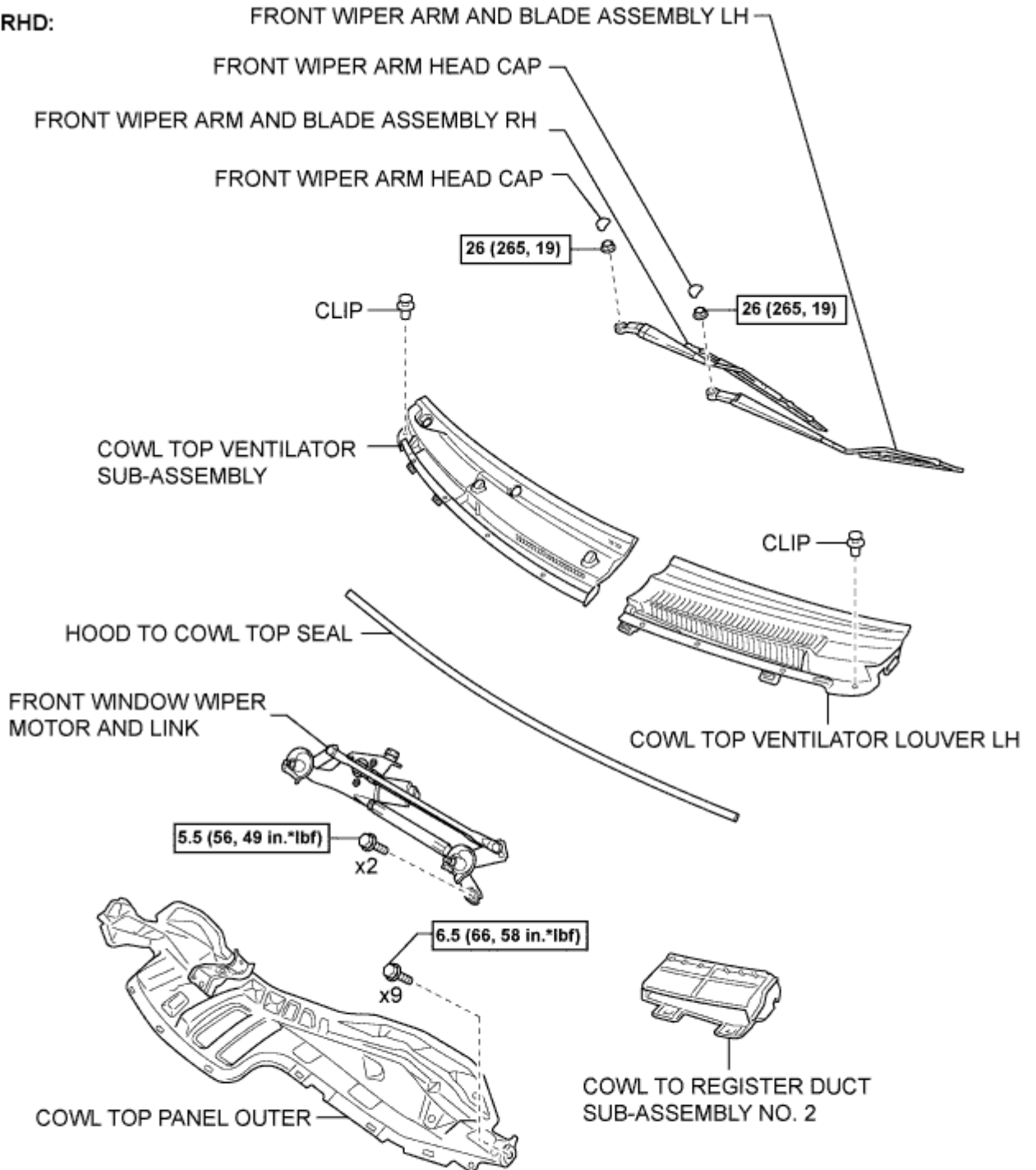

N*m (kgf*cm, ft.*lbf) : Specified torque

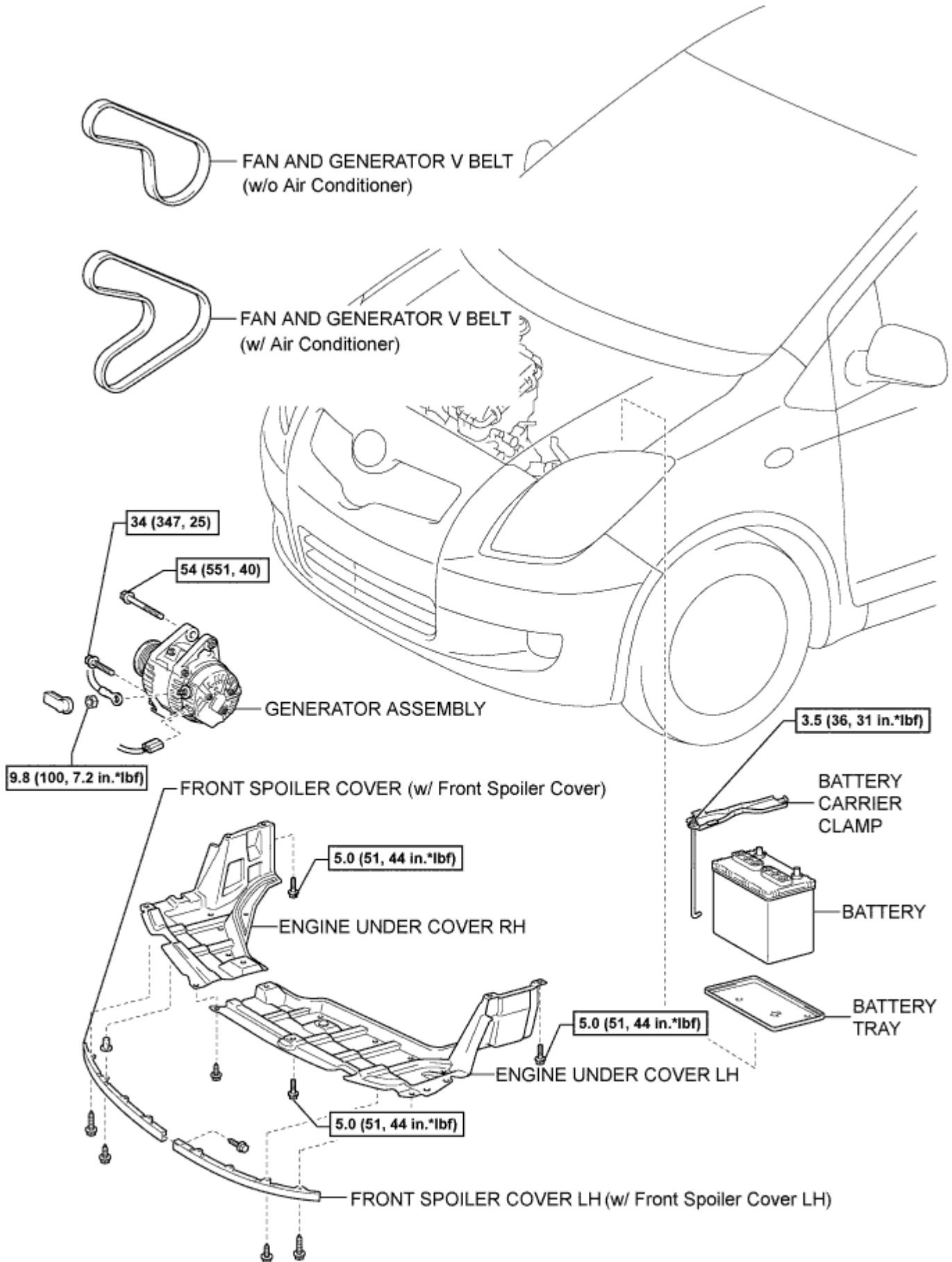

N*m (kgf*cm, ft.*lbf) : Specified torque

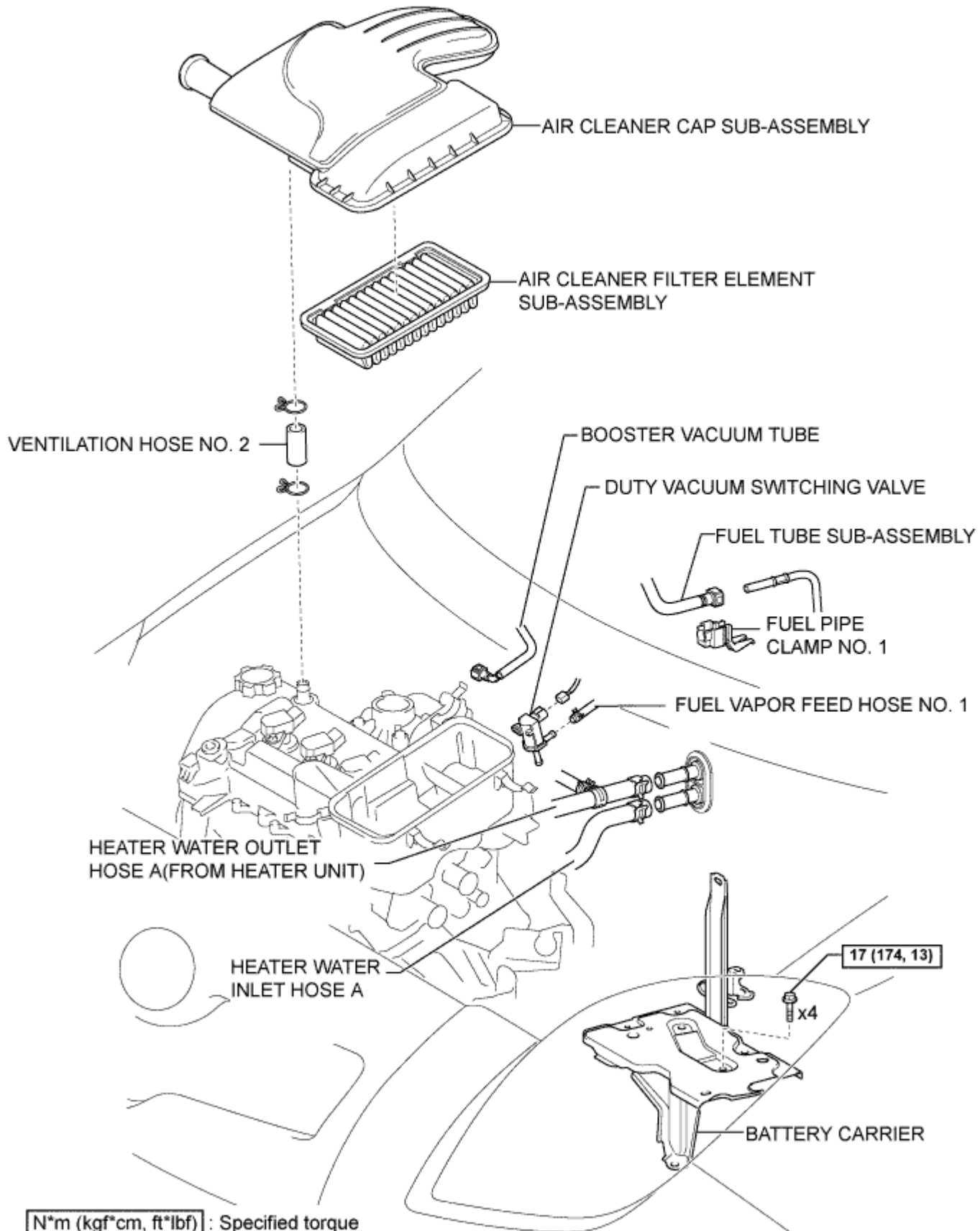

N*m (kgf*cm, ft*lbf) : Specified torque

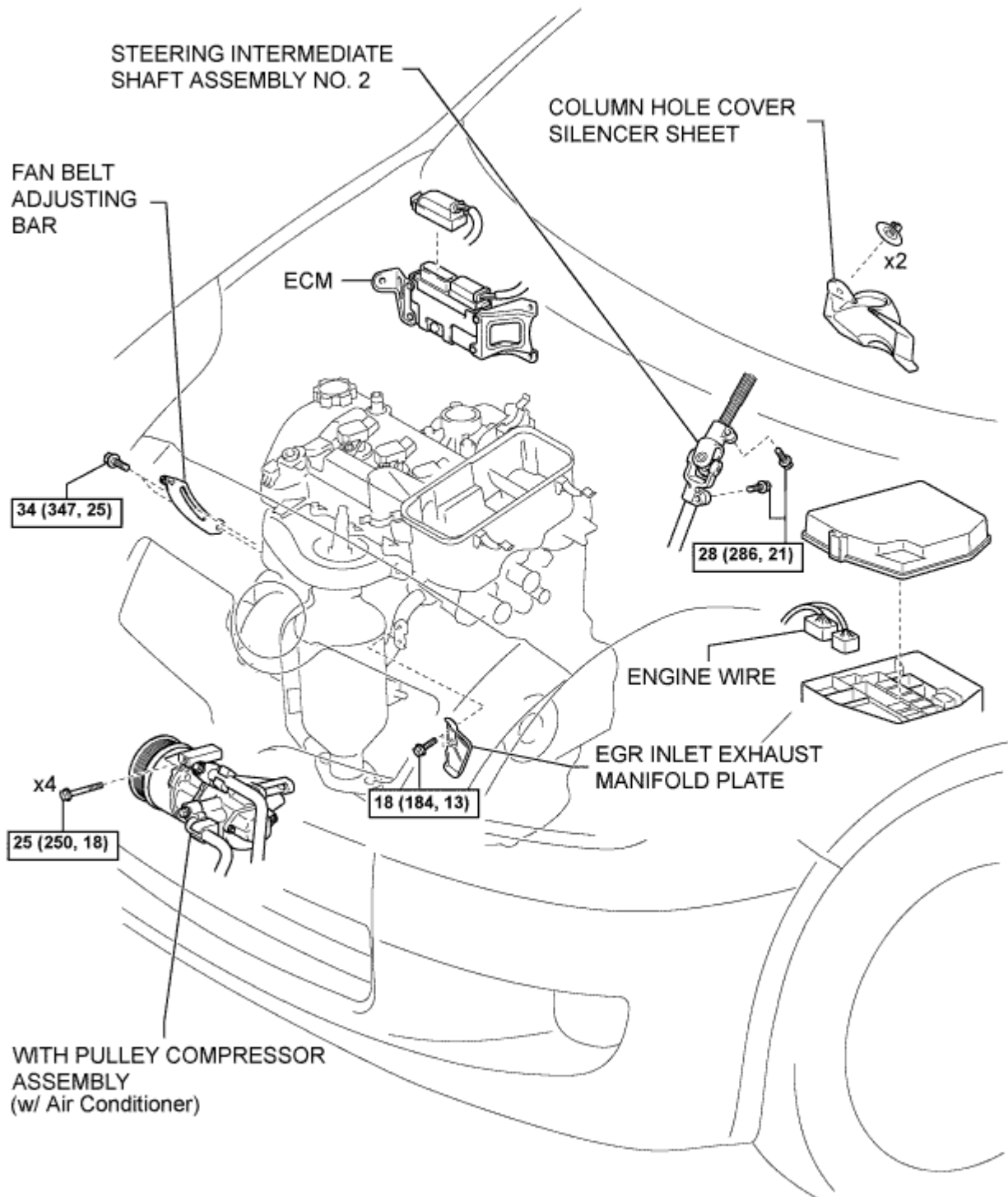

N*m (kgf*cm, ft*lbf) : Specified torque

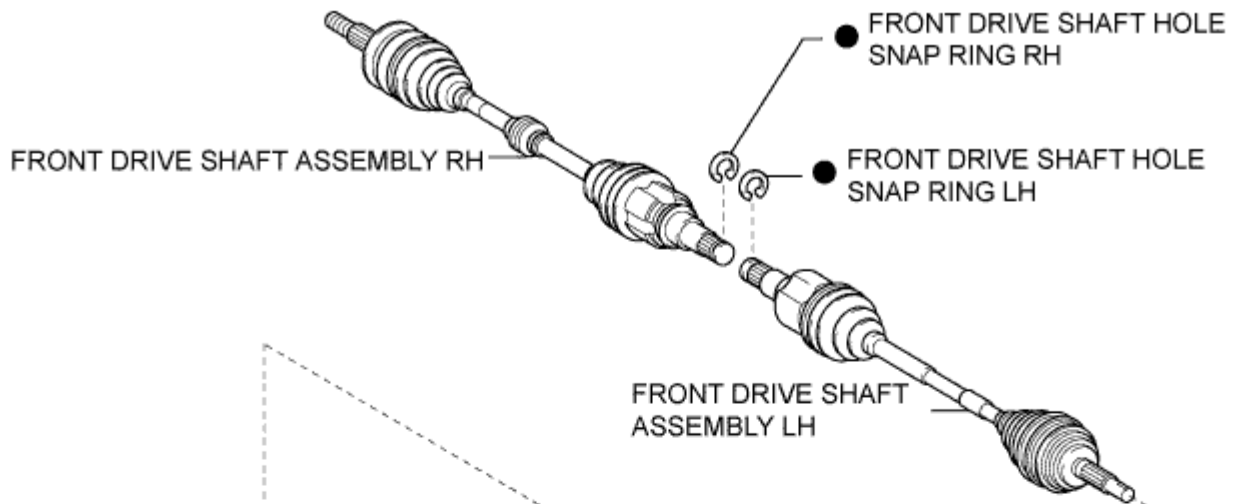

FRONT STABILIZER LINK ASSEMBLY LH

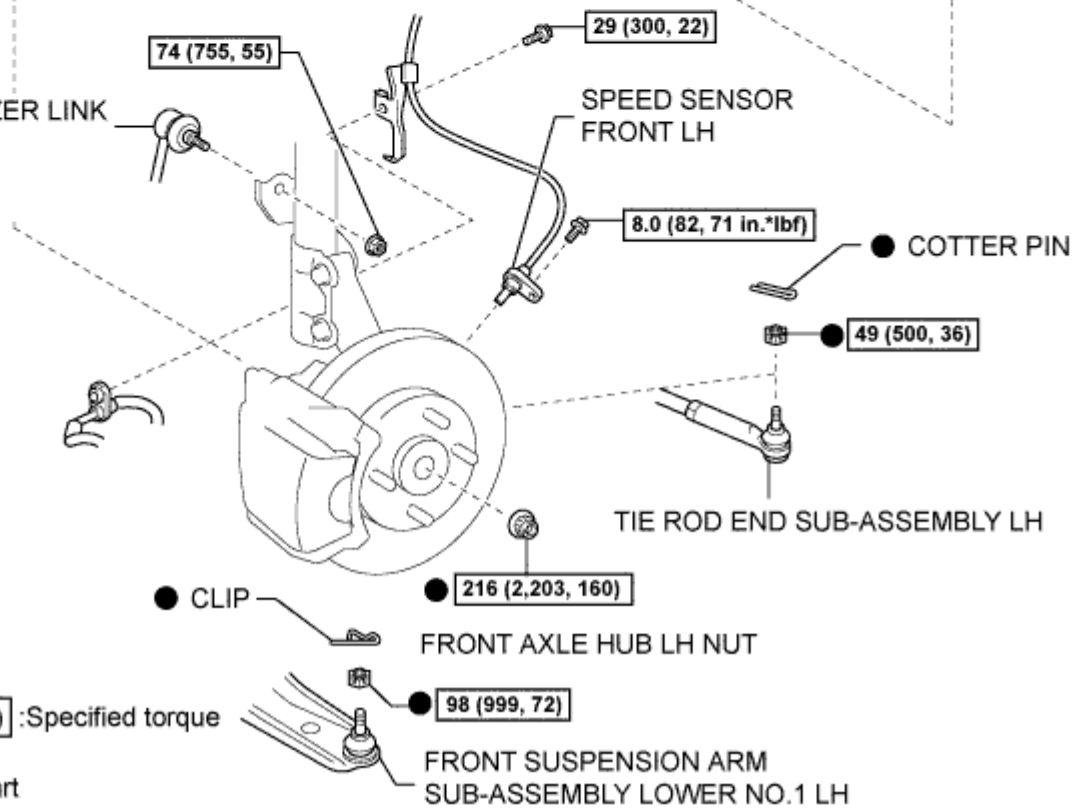

N*m (kgf*cm, ft*lbf) : Specified torque

● Non-reusable part

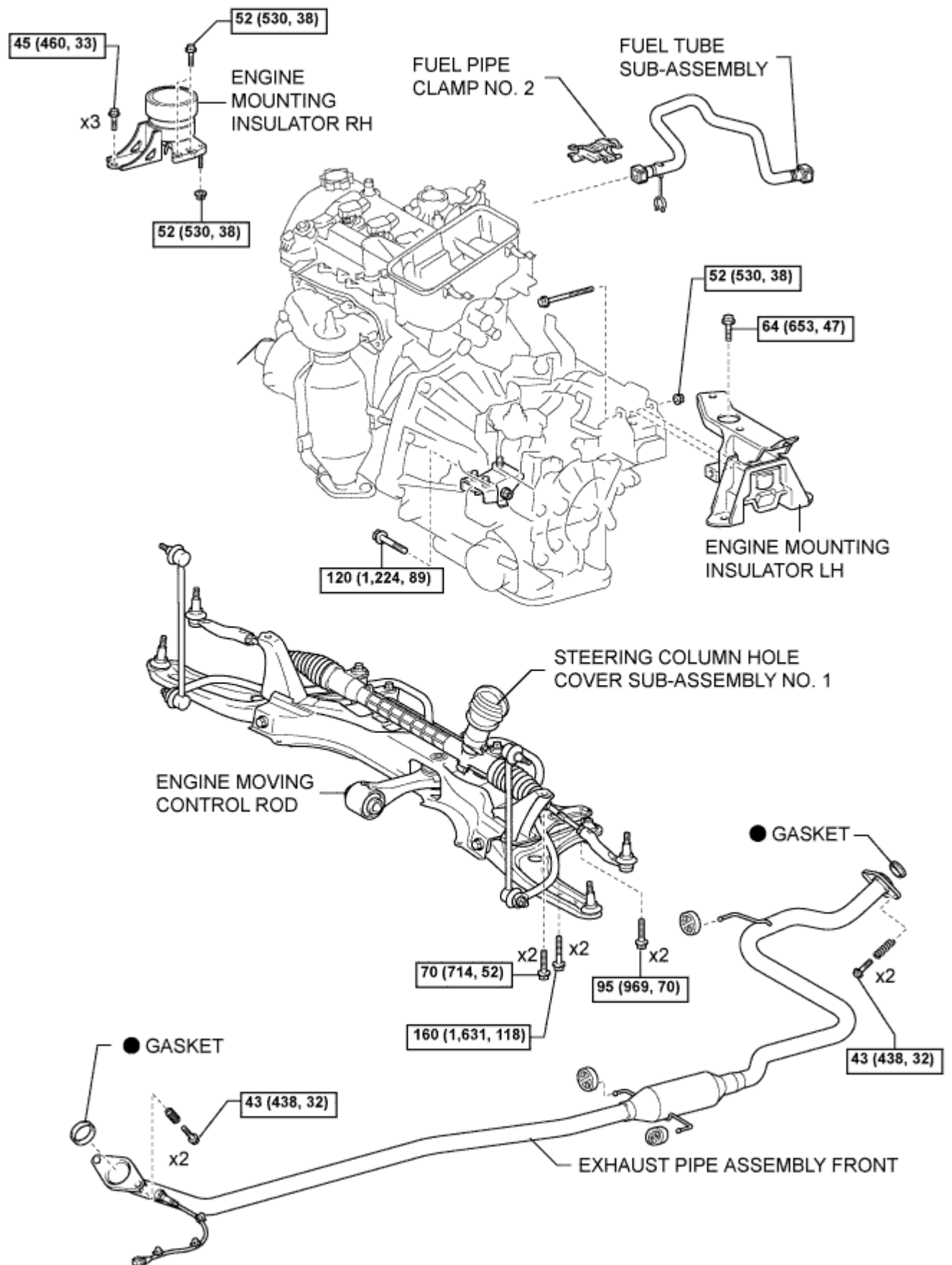

N*m (kgf*cm, ft*lbf) : Specified torque

● Non-reusable part

for Manual Transaxle:

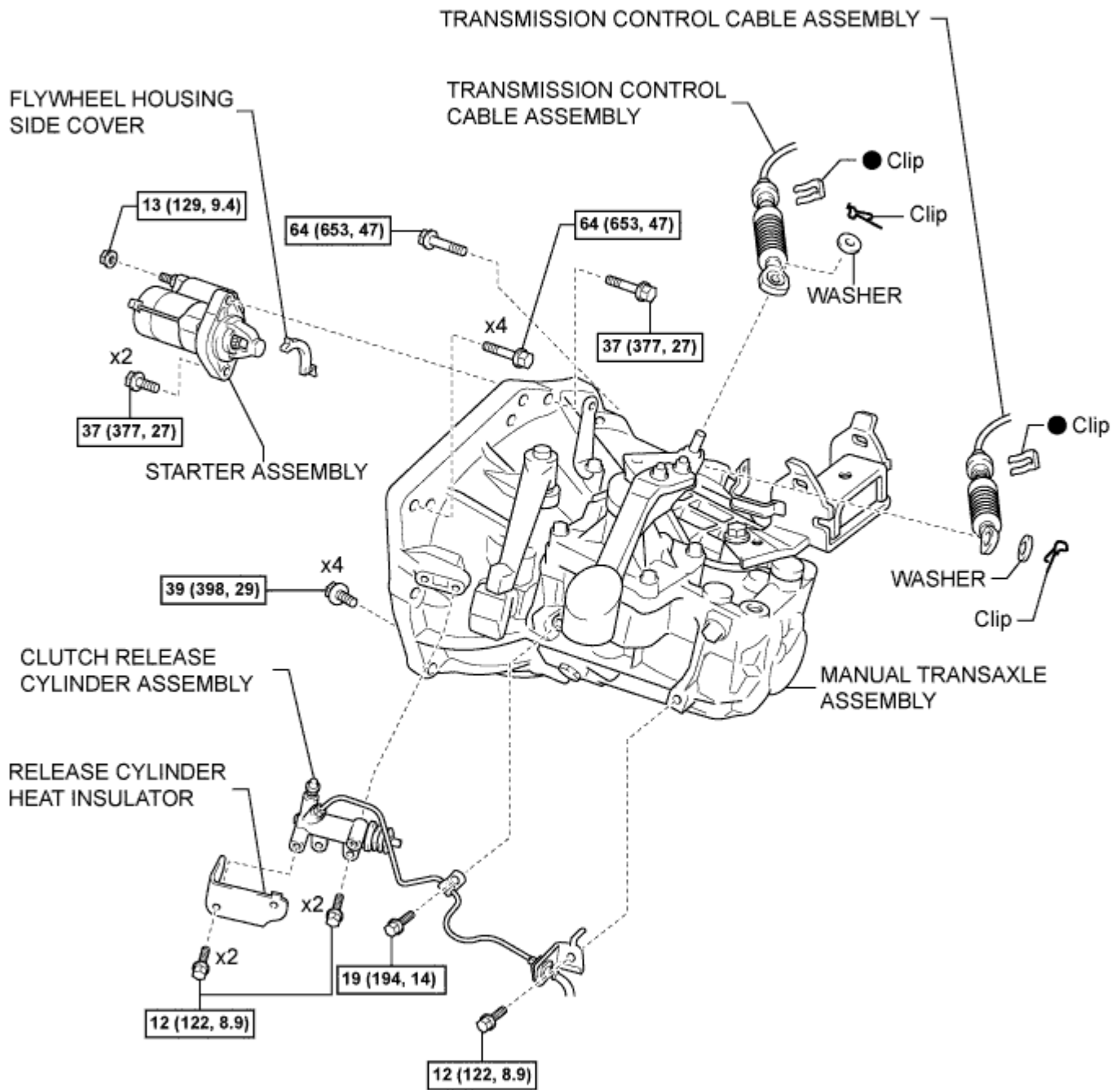

N*m (kgf*cm, ft.*lbf) : Specified torque

● Non-reusable part

for Manual Transaxle:

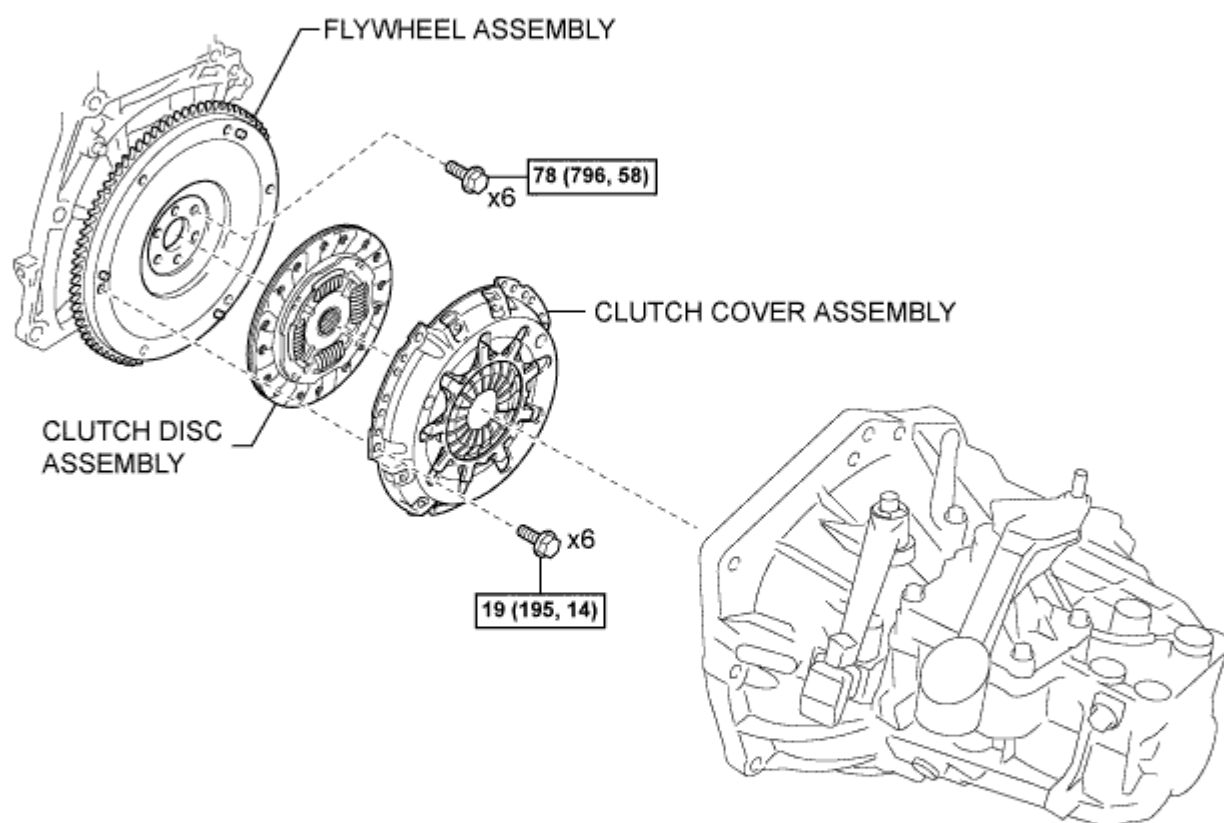

N*m (kgf*cm, ft.*lbf) : Specified torque

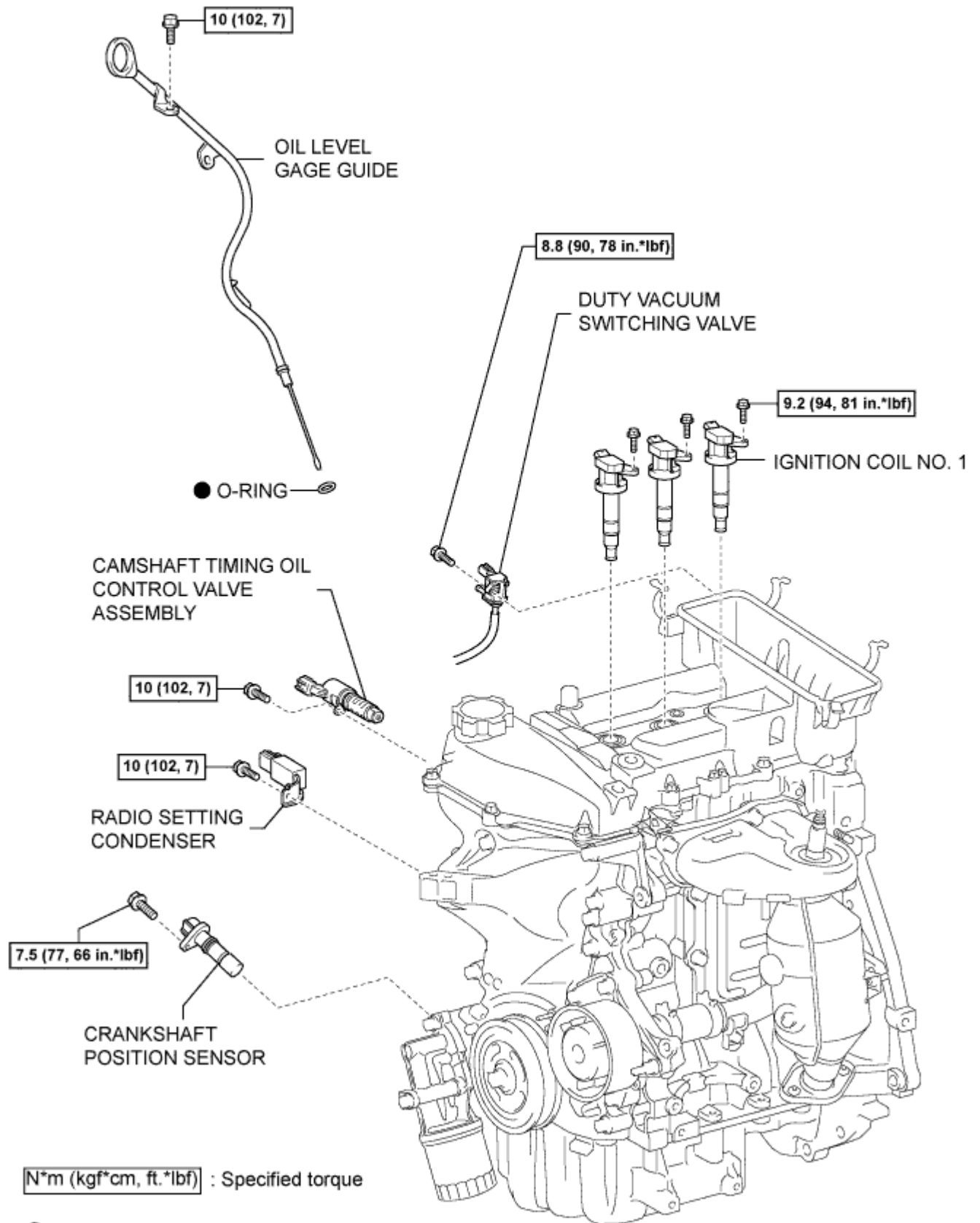

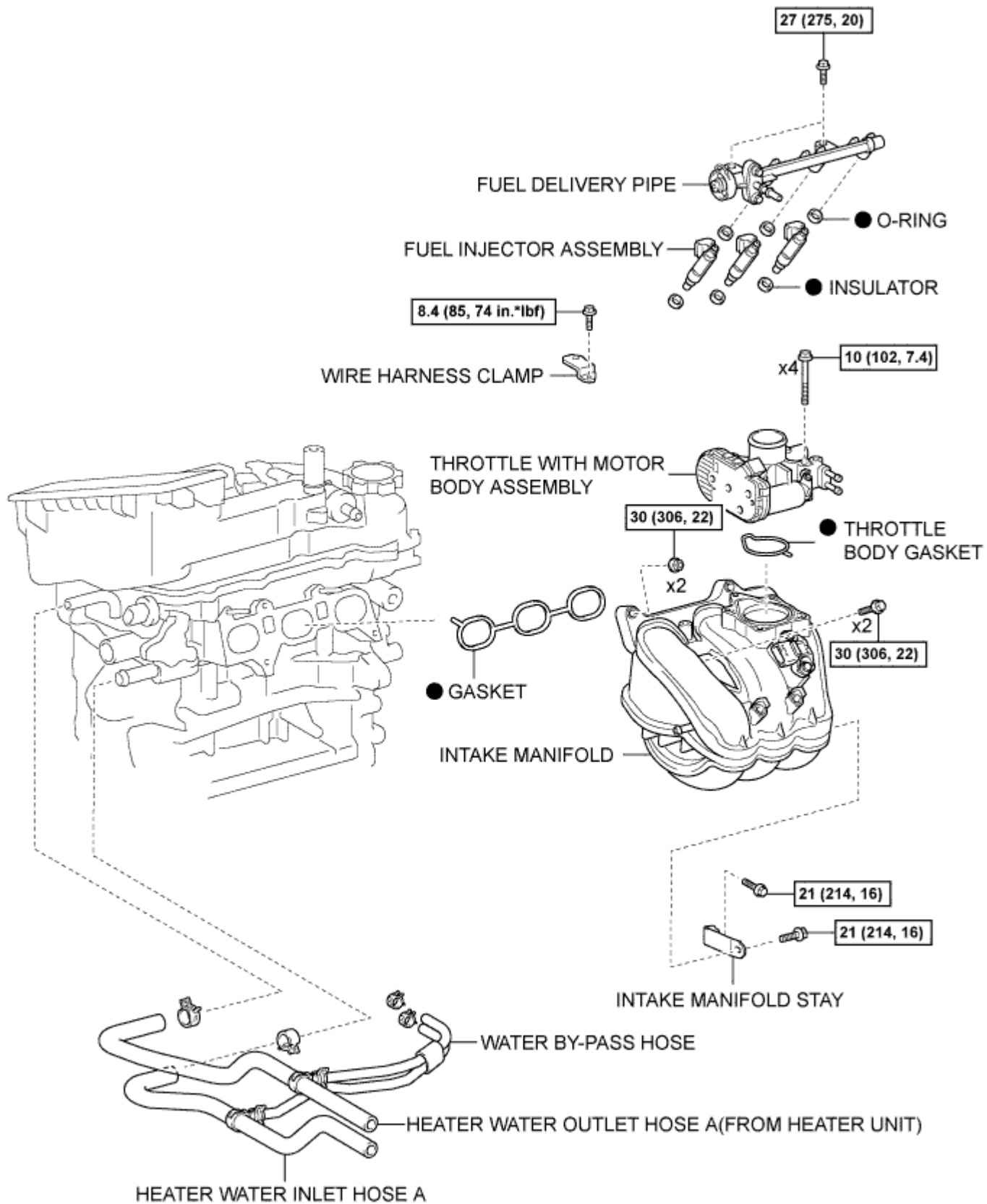

N*m (kgf*cm, ft.*lbf) : Specified torque

● Non-reusable part

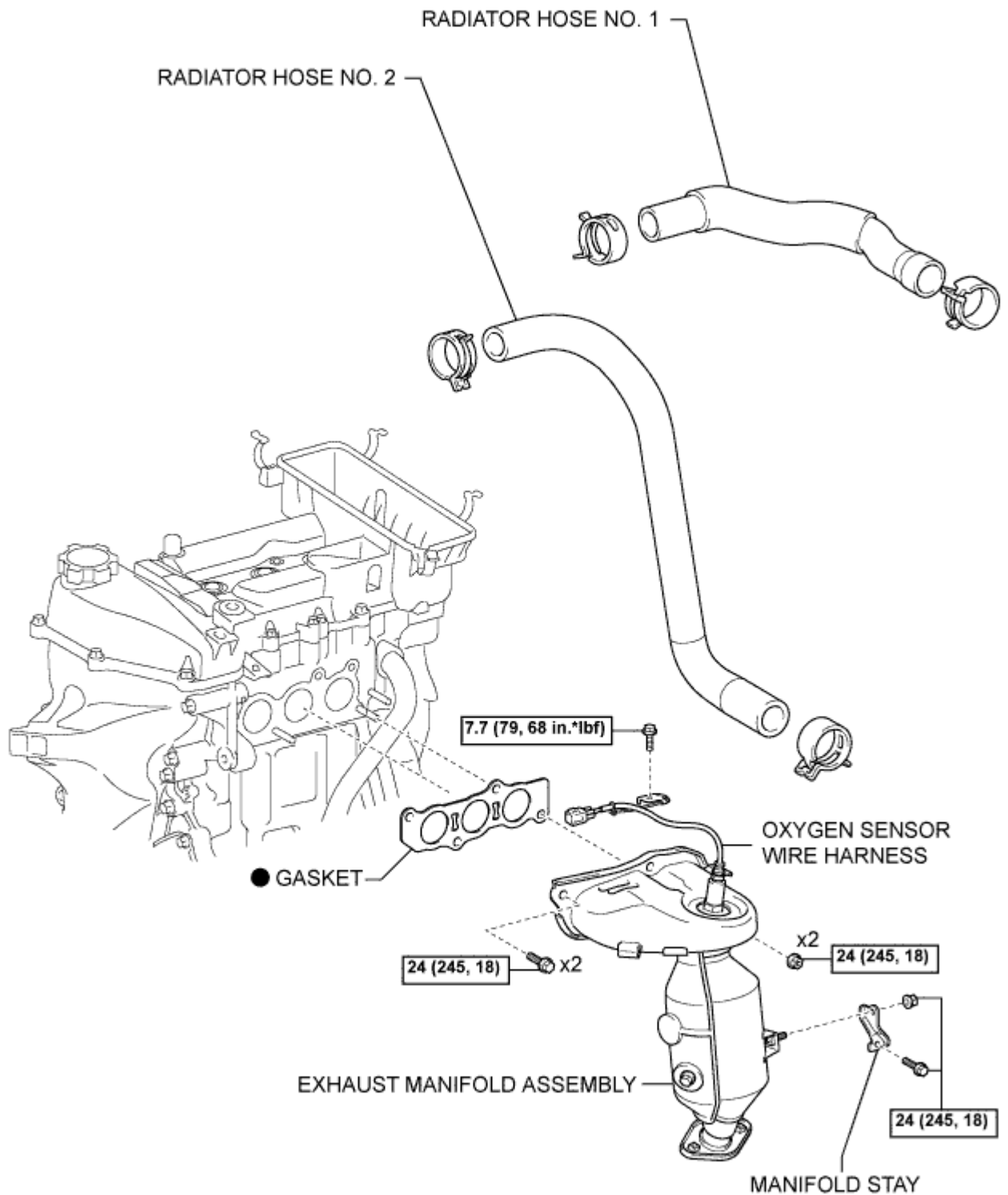

N*m (kgf*cm, ft*lbf) : Specified torque

● Non-reusable part

ENGINE ASSEMBLY > COMPONENTS

for LHD:

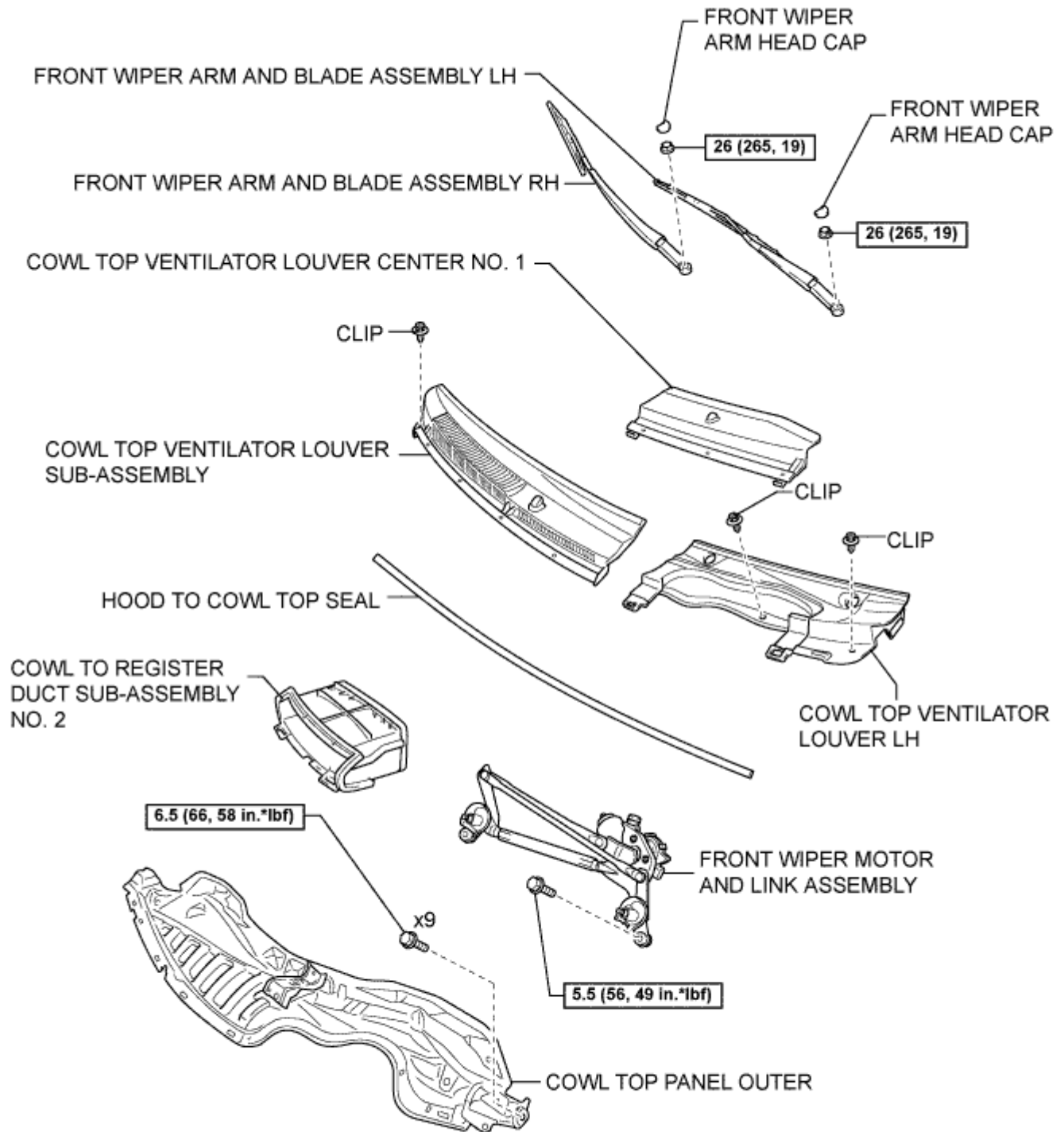

N*m (kgf*cm, ft*lbf) : Specified torque

for RHD:

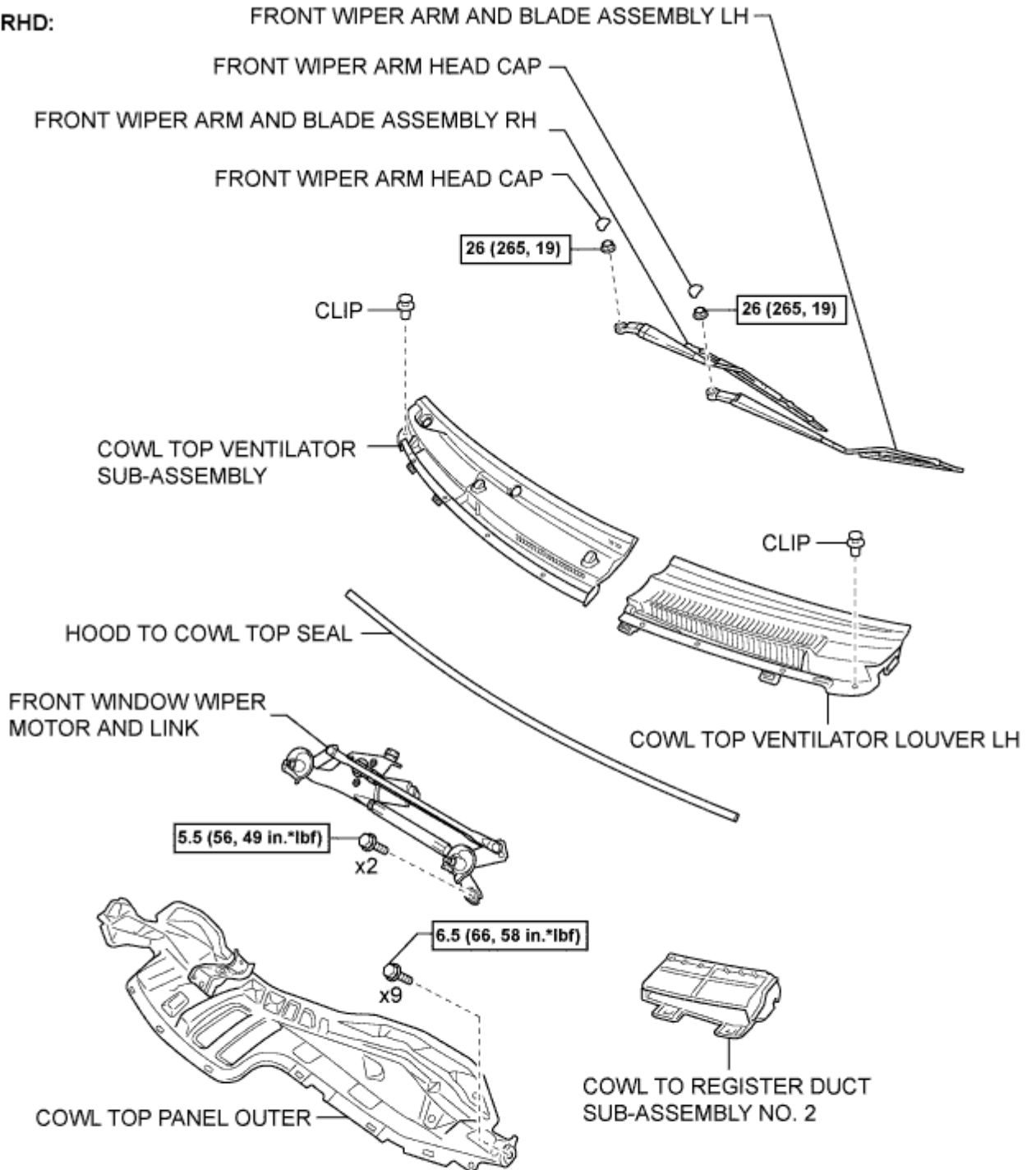

N*m (kgf*cm, ft.*lbf) : Specified torque

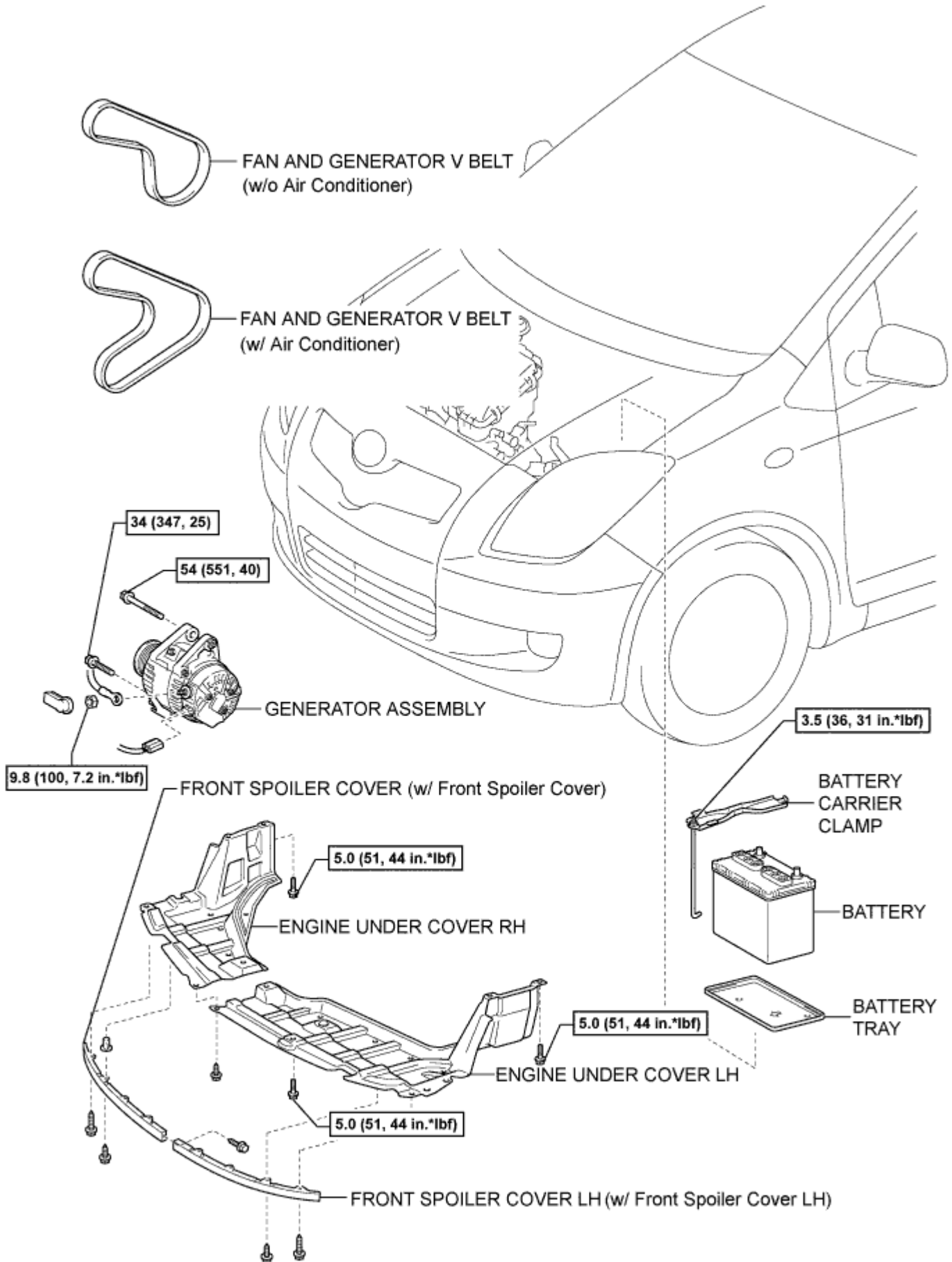

N*m (kgf*cm, ft.*lbf) : Specified torque

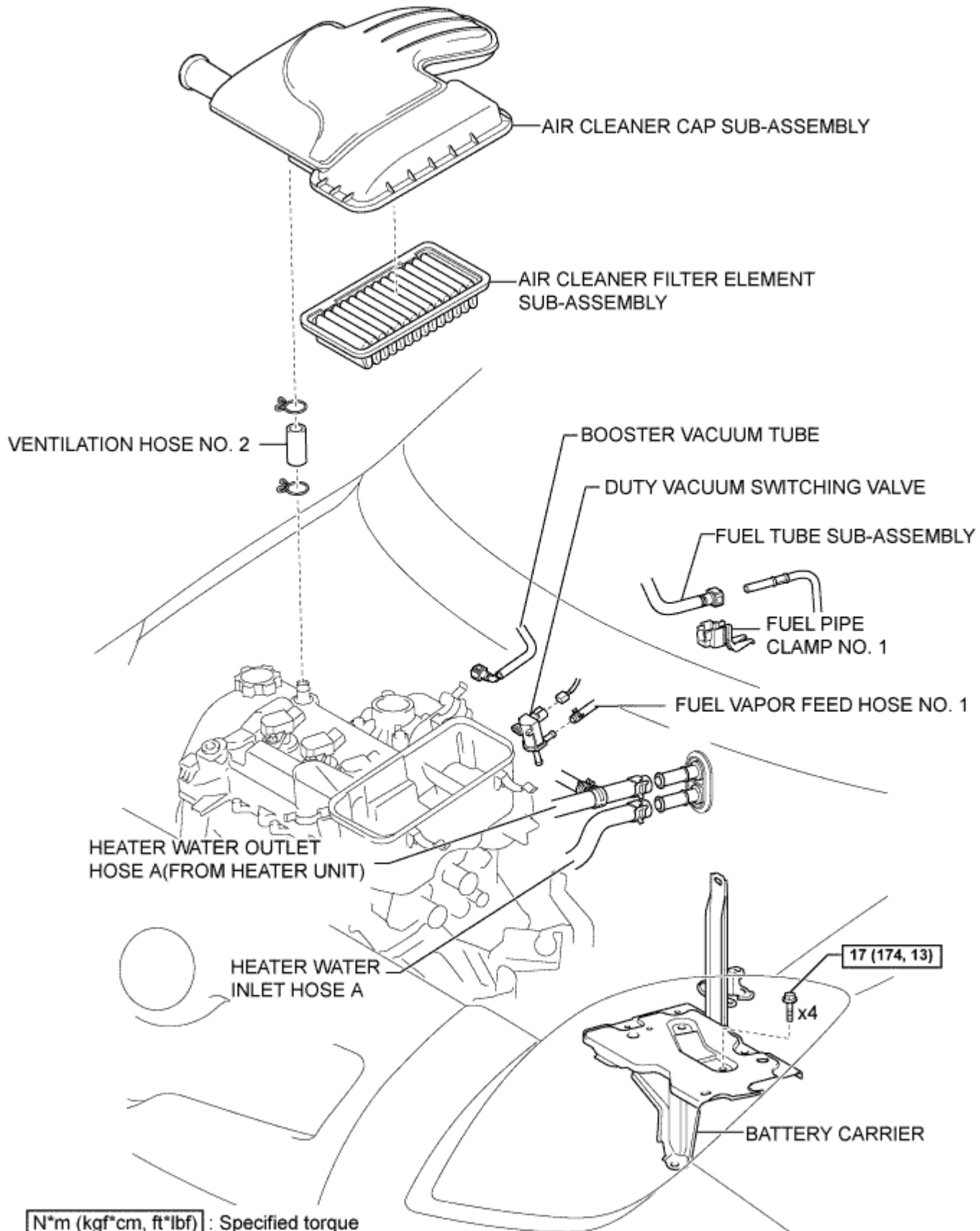

N*m (kgf*cm, ft*lbf) : Specified torque

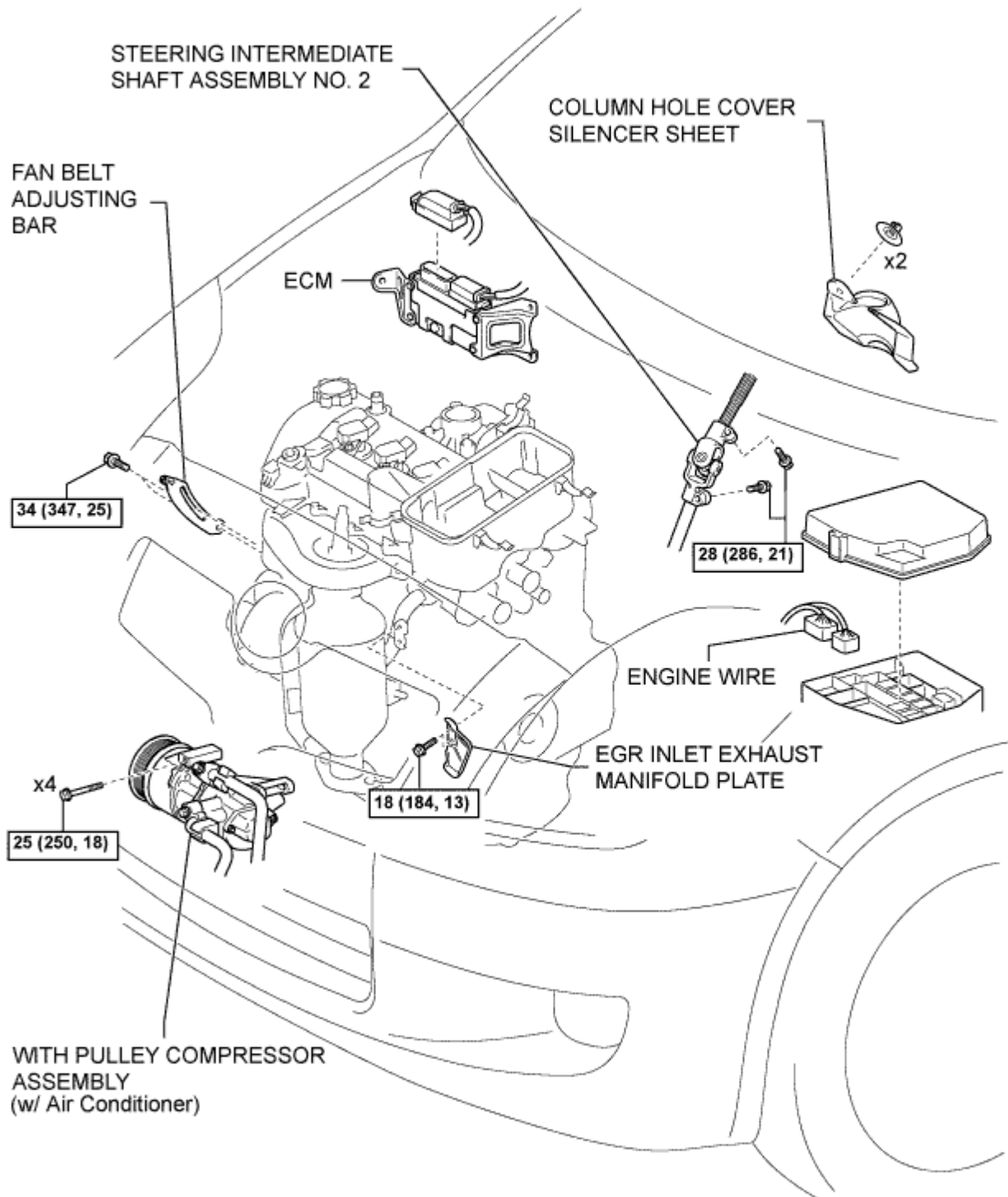

N*m (kgf*cm, ft*lbf) : Specified torque

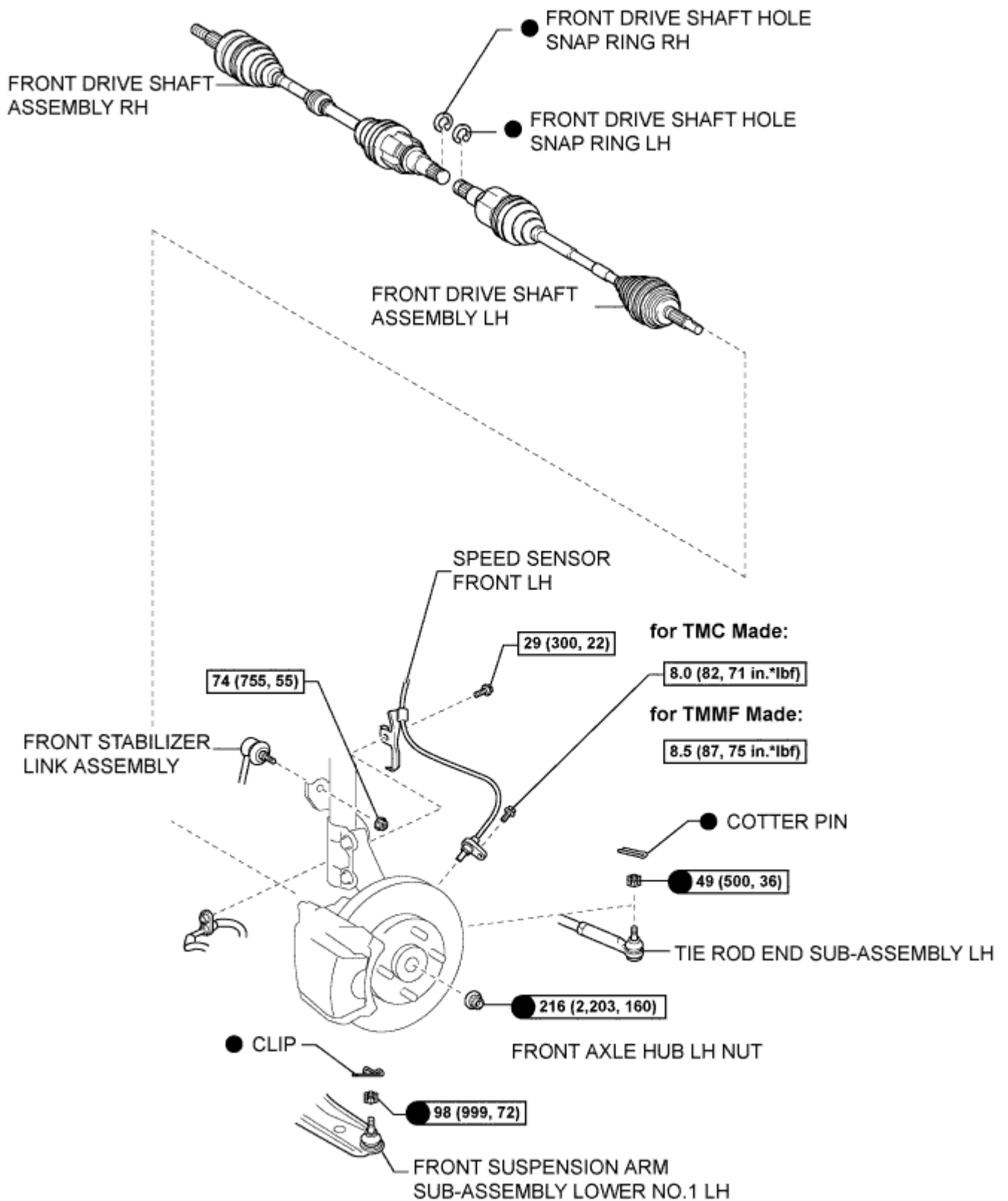

N*m (kgf*cm, ft*lbf) :Specified torque

● Non-reusable part

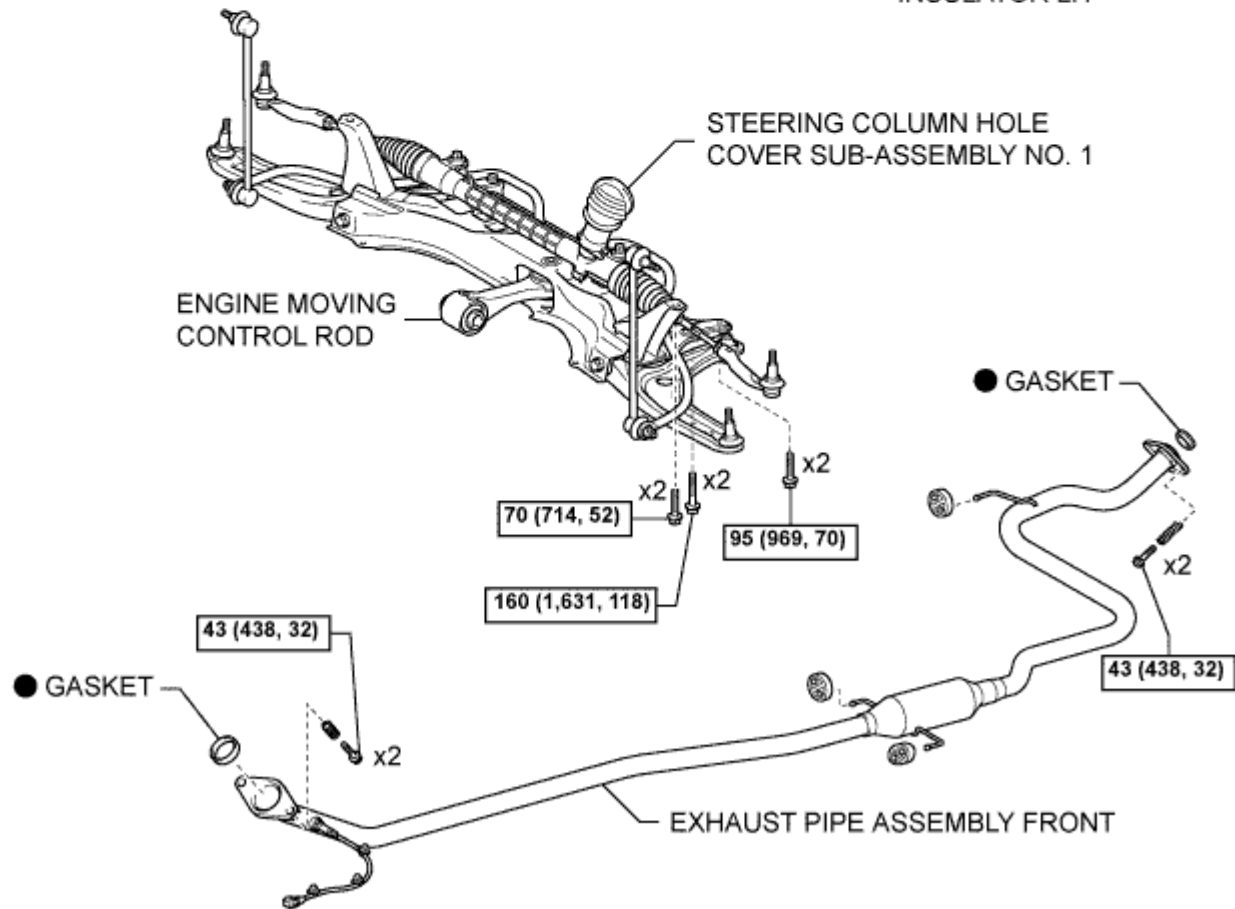
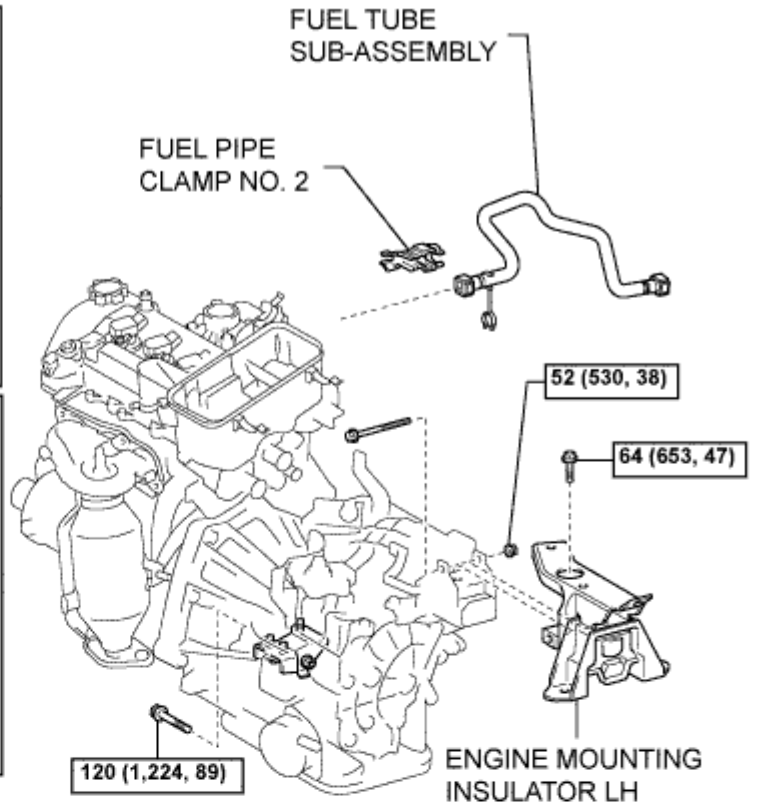
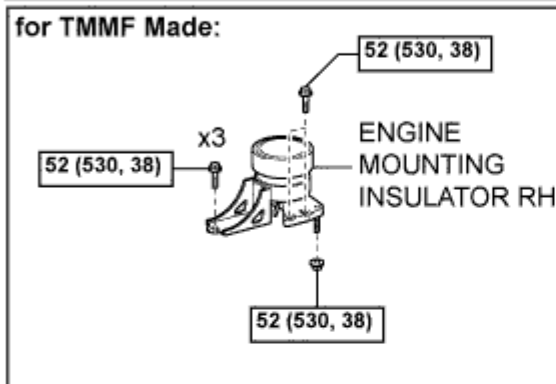
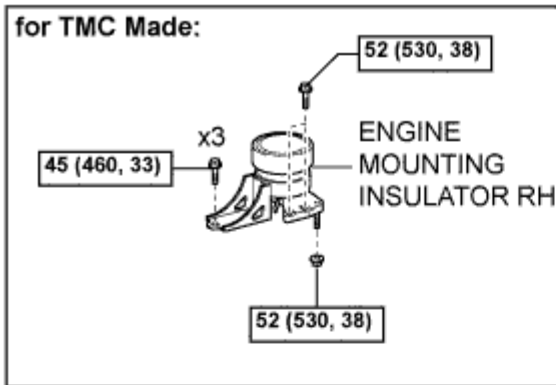

N*m (kgf*cm, ft*lbf) : Specified torque

● Non-reusable part

for Multi-mode Manual Transaxle:

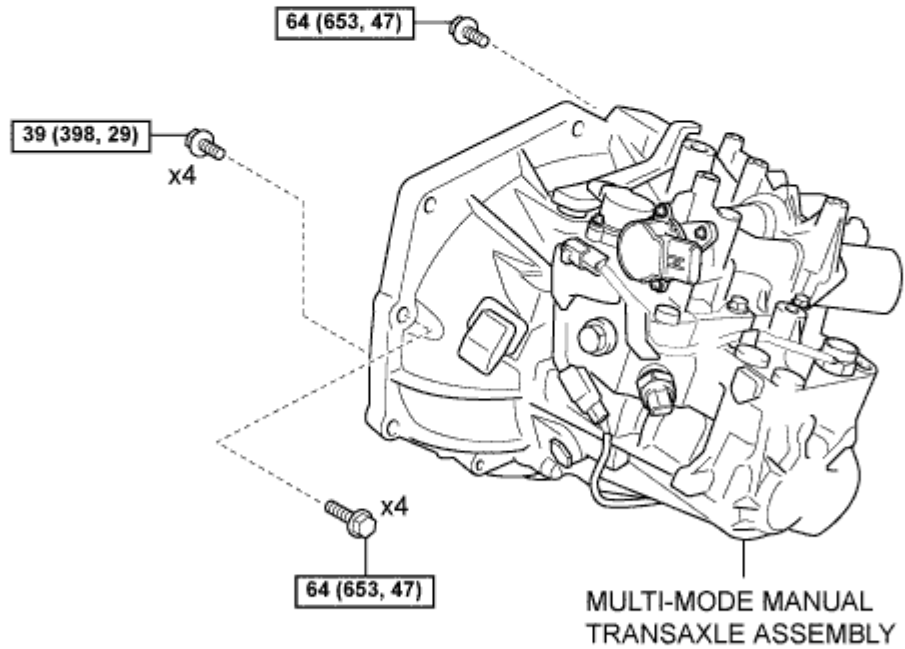
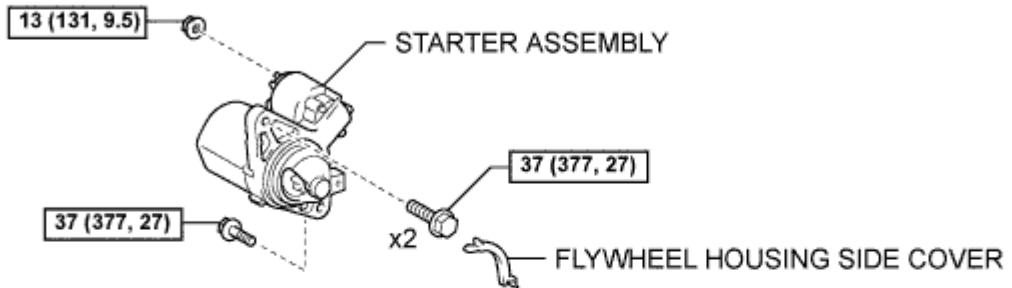

N*m (kgf*cm, ft*lb) : Specified torque

for Manual Transaxle:

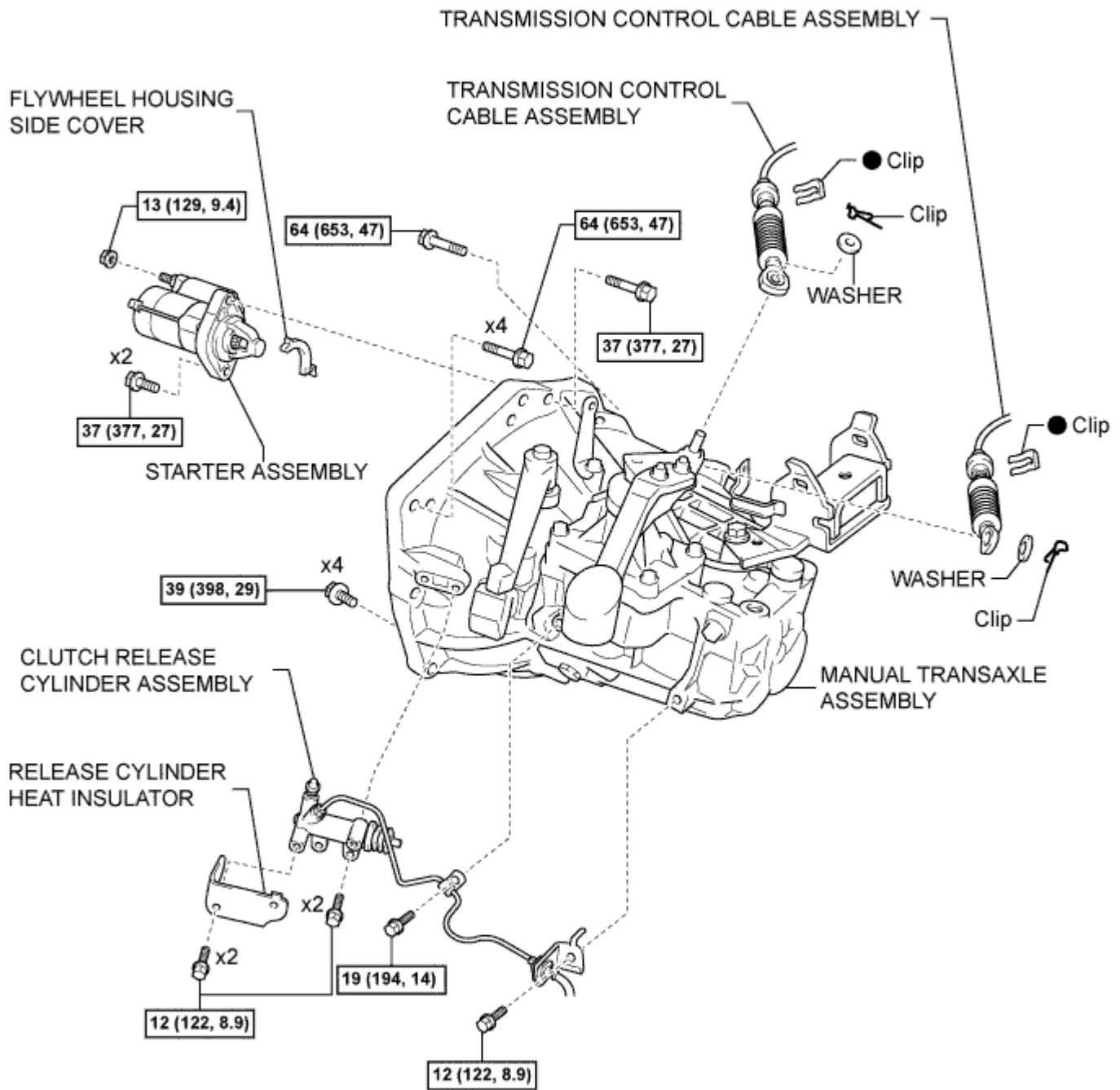

N*m (kgf*cm, ft.*lbf) : Specified torque

● Non-reusable part

for Multi-mode Manual Transaxle:

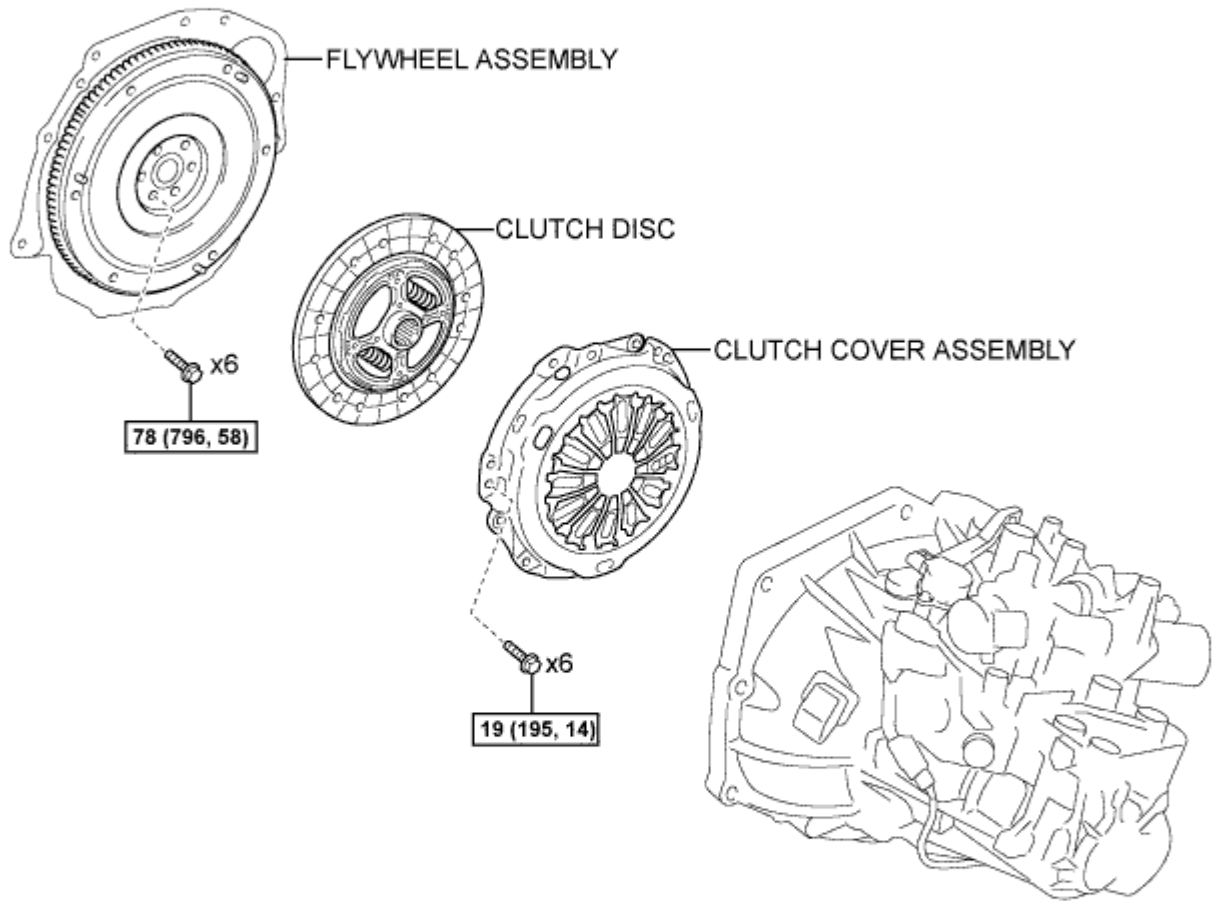

N*m (kgf*cm, ft.*lbf); Specified torque

for Manual Transaxle:

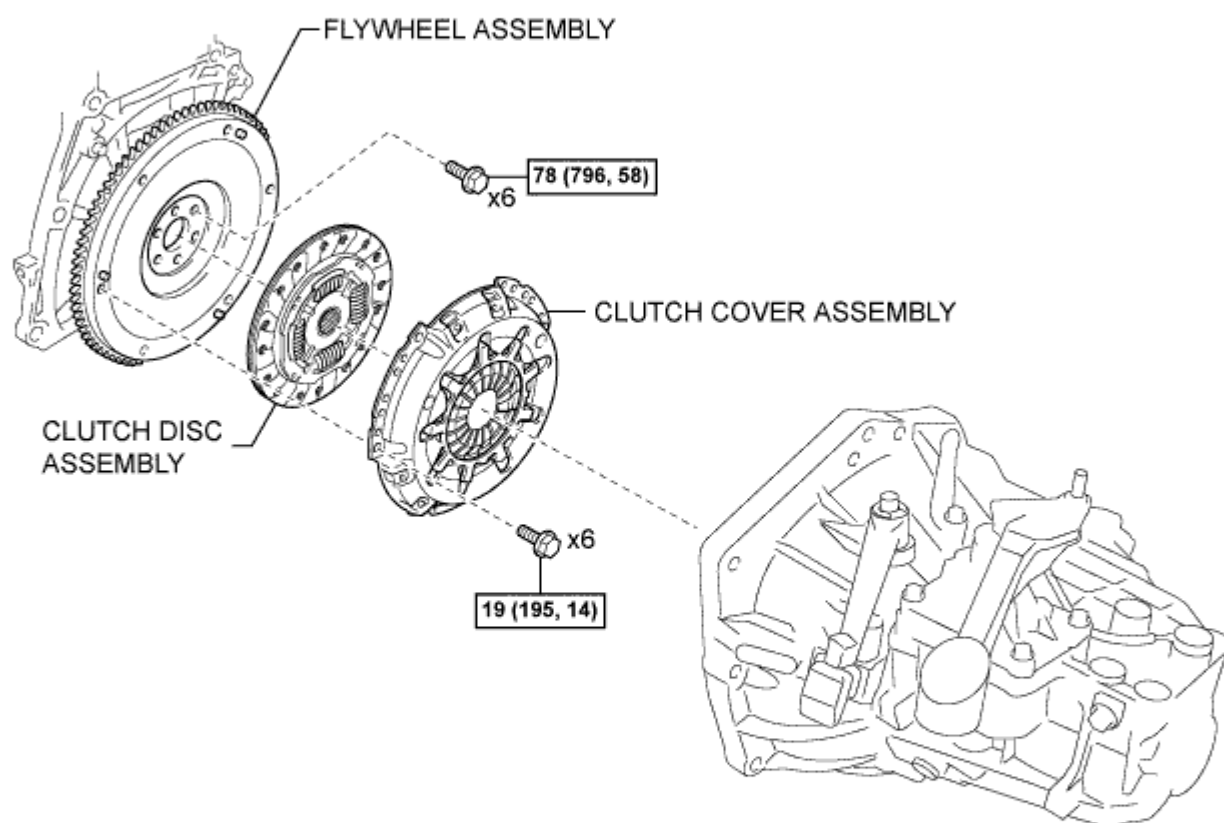

[N*m (kgf*cm, ft.*lbf)] : Specified torque

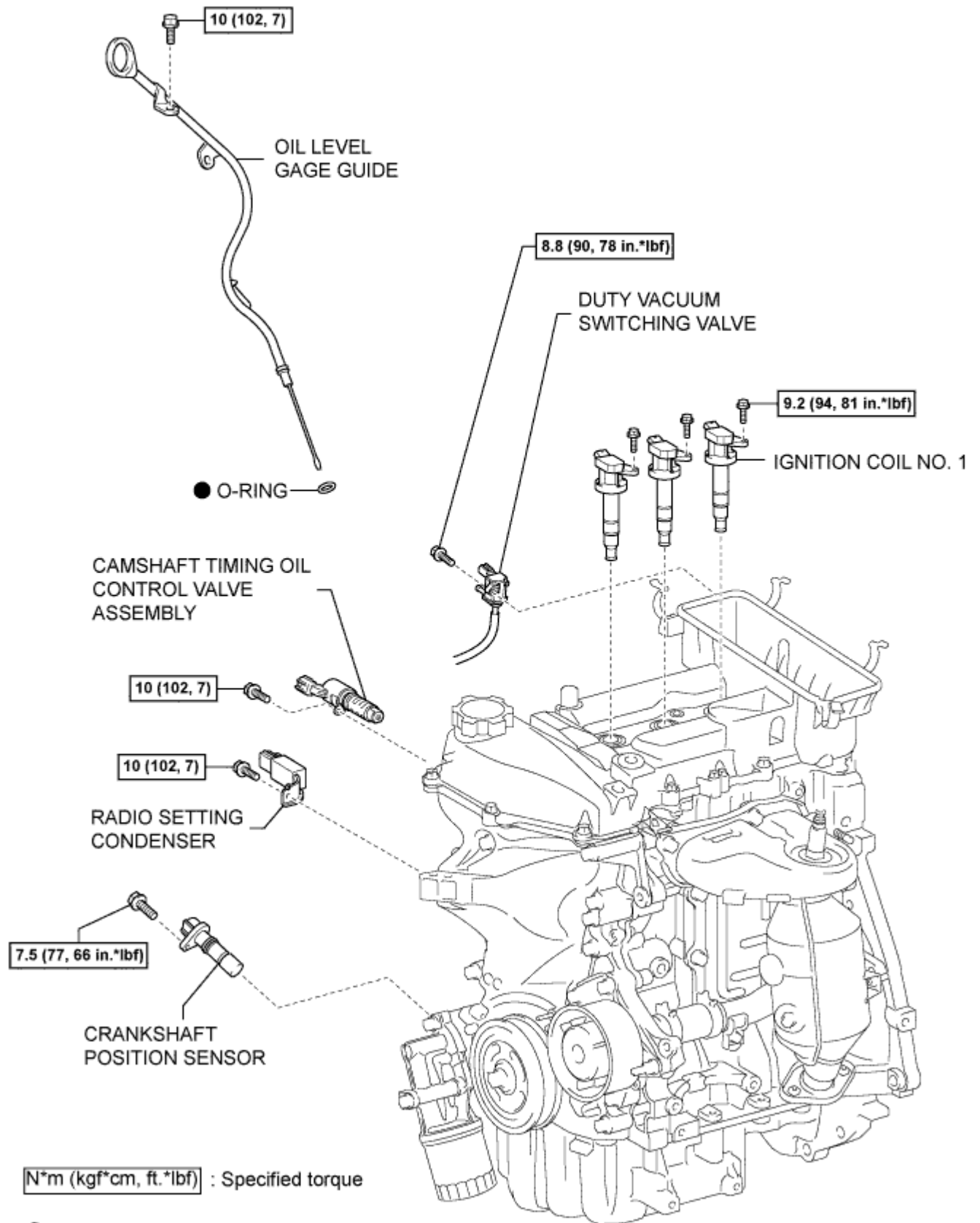

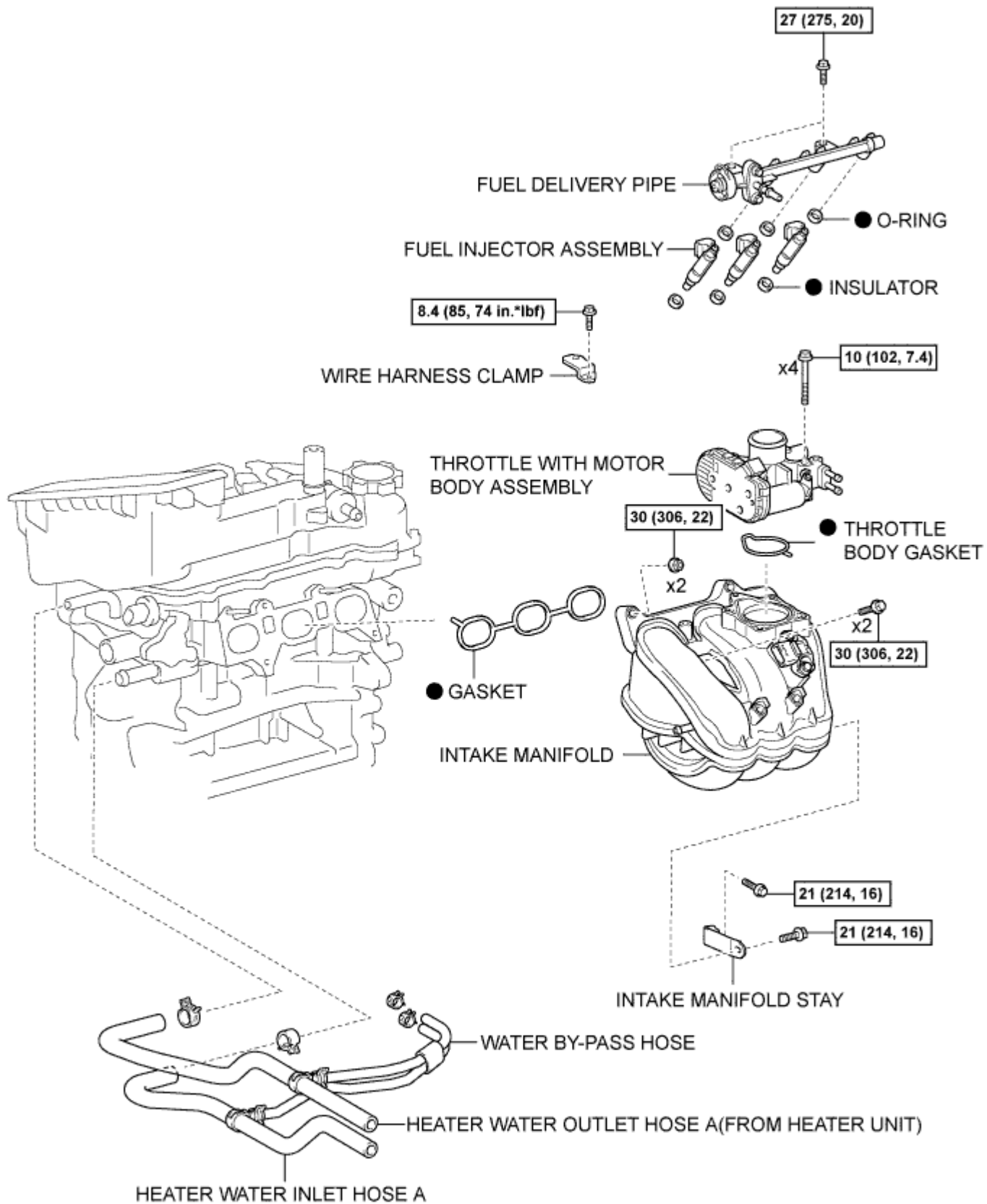

N*m (kgf*cm, ft.*lbf) : Specified torque

● Non-reusable part

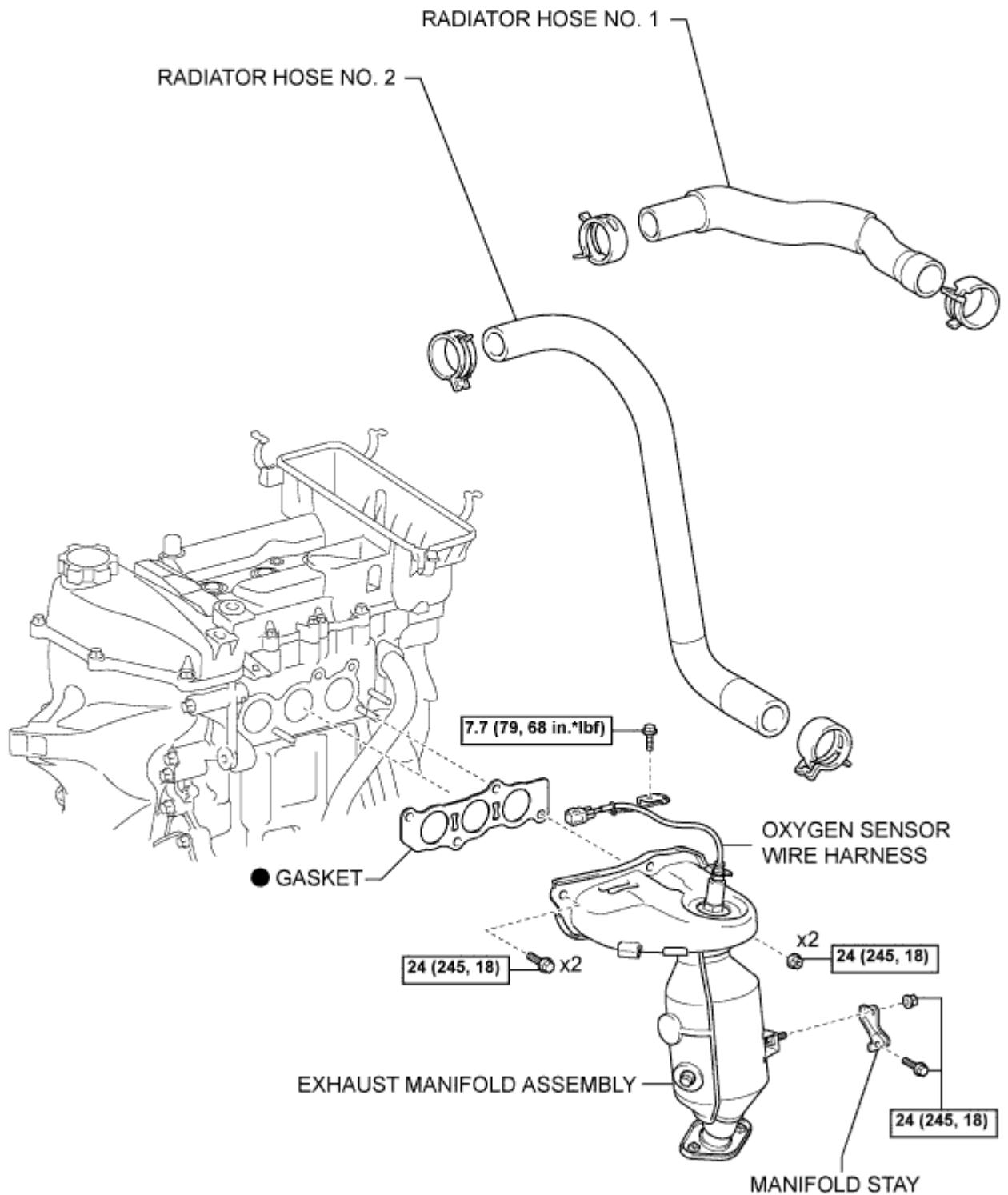

N*m (kgf*cm, ft*lbf) : Specified torque

● Non-reusable part

ENGINE ASSEMBLY > REMOVAL

1. DISCHARGE FUEL SYSTEM PRESSURE

0

2. REMOVE BATTERY

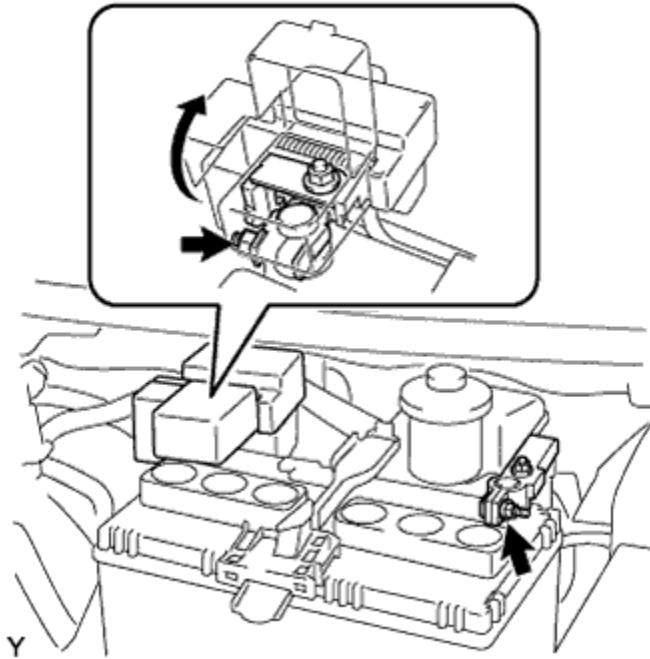

1. Disconnect the negative battery terminal.
2. Disconnect the positive battery terminal.

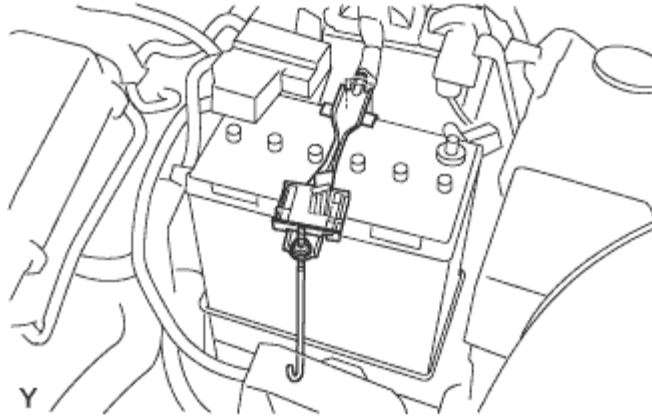

3. Loosen the nut, and remove the battery carrier clamp.
4. Remove the battery from the vehicle.

3. REMOVE BATTERY TRAY

4. REMOVE BATTERY CARRIER

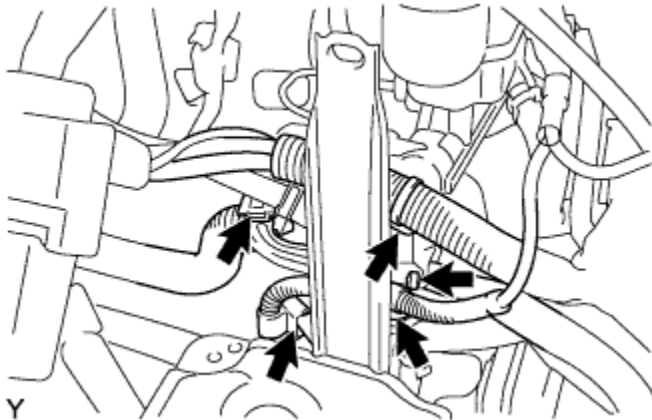

1. Disengage the 5 clamps, and separate the engine wire harness.

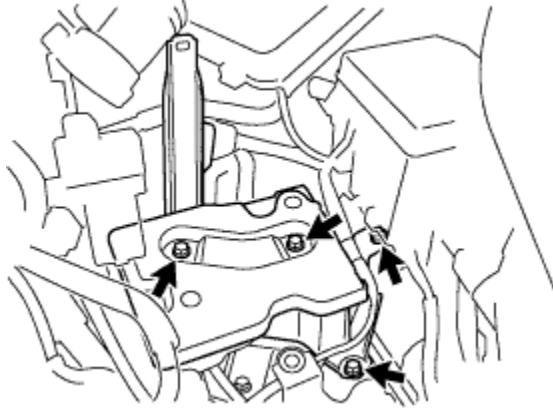

2. Remove the 4 bolts, and remove the battery carrier.

5. REMOVE FRONT SPOILER COVER LH (w/ Front Spoiler Cover LH)

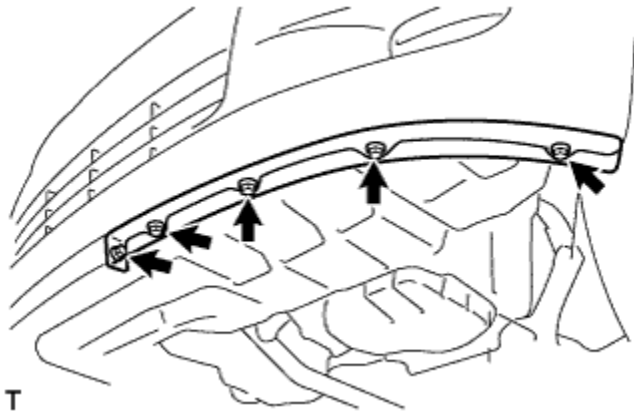

1. Remove the 5 screws and the front spoiler cover.

6. REMOVE FRONT SPOILER COVER (w/ Front Spoiler Cover)

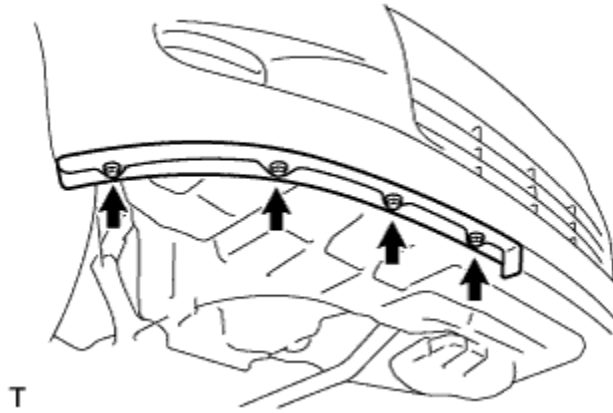

1. Remove the 4 screws and the front spoiler cover.

7. REMOVE ENGINE UNDER COVER LH

8. REMOVE ENGINE UNDER COVER RH

9. DRAIN ENGINE COOLANT

CAUTION:

To avoid the danger of being burned, do not remove the radiator cap sub-assembly while the engine and radiator assembly are still hot. Thermal expansion will cause hot engine coolant and steam to blow out from the radiator assembly.

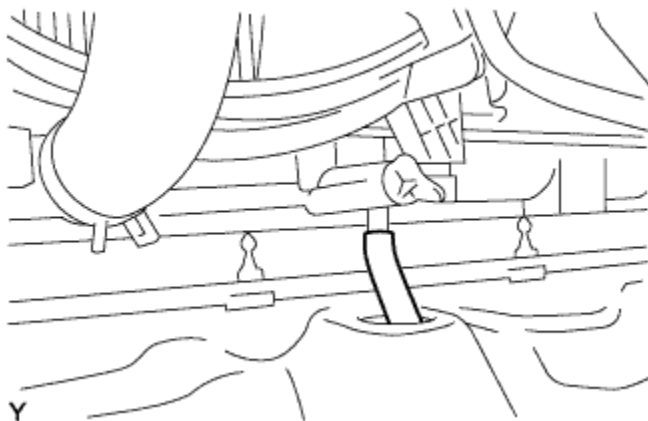

1. Install a vinyl hose onto the radiator side.
2. Loosen the radiator drain cock plug.
3. Remove the radiator cap sub-assembly.
4. Loosen the water drain plug, then drain the coolant.

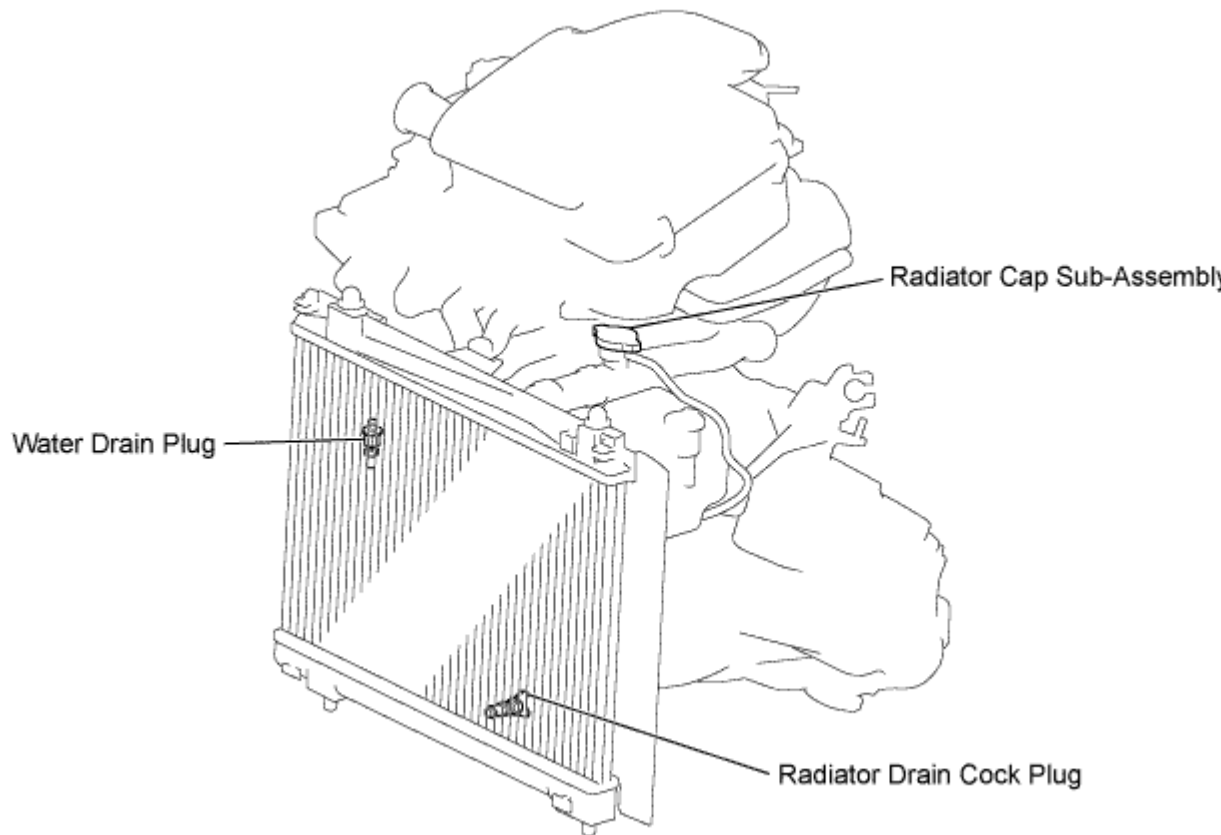

Y

10. DRAIN TRANSAXLE OIL

1. Remove the filler plug and gasket.
2. Remove the drain plug and gasket, and then drain the manual transaxle oil.
3. Install a new gasket and the drain plug.

Torque:

39 N*m { 400 kgf*cm , 29 ft.*lbf }

11. REMOVE EGR INLET EXHAUST MANIFOLD PLATE

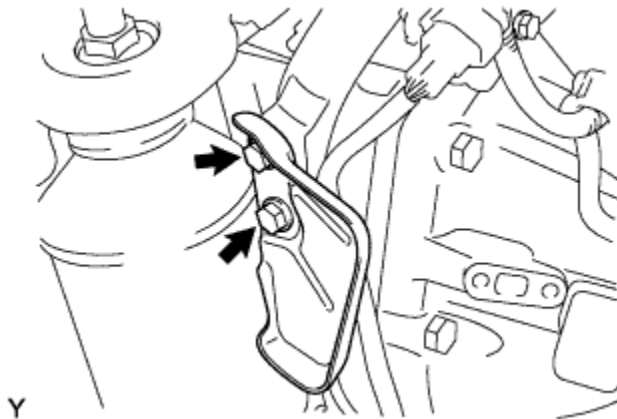

1. Remove the 2 bolts and the EGR inlet exhaust manifold plate.

12. REMOVE EXHAUST PIPE ASSEMBLY FRONT

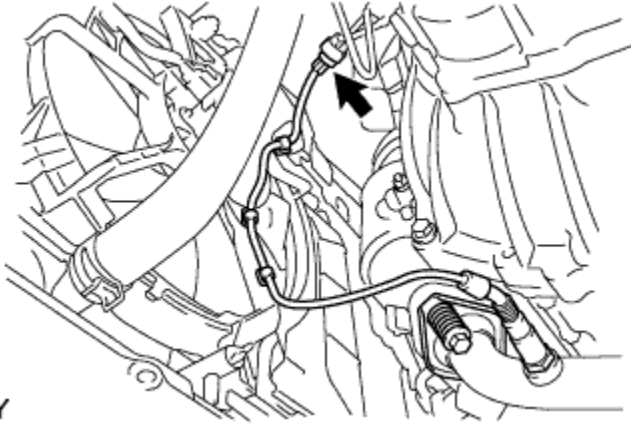

1. Disconnect the oxygen sensor connector, and disengage the 3 wire harness clamps.

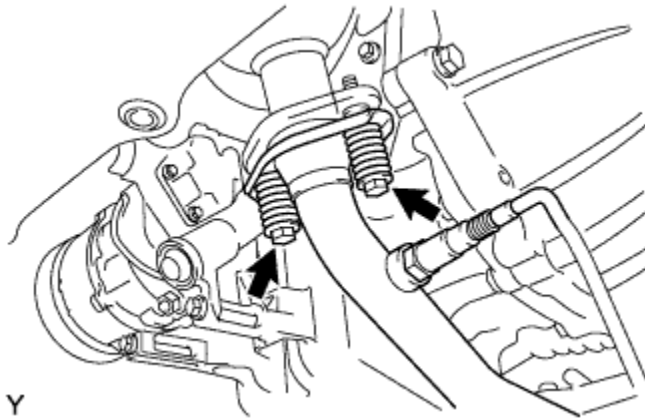

2. Remove the 2 bolts and compression springs, and separate the exhaust pipe front from the exhaust manifold.

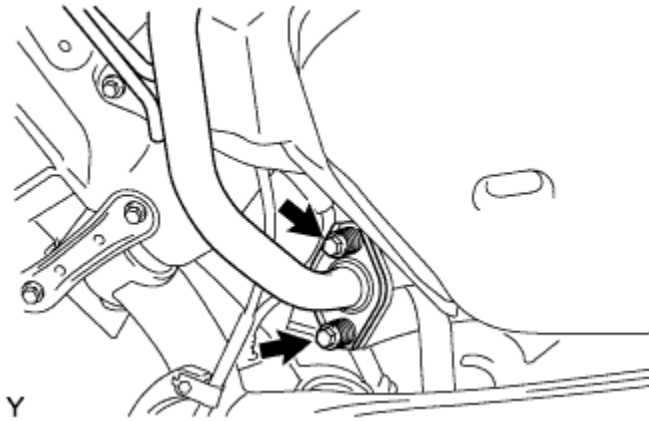

3. Remove the 2 bolts and compression springs, and separate the exhaust pipe front from the exhaust pipe tail.

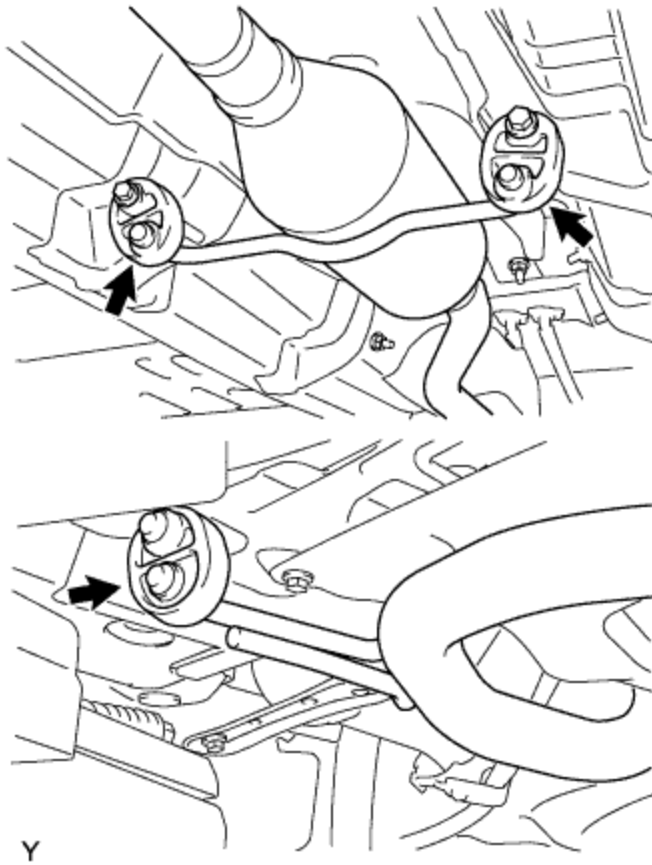

4. Remove the 3 supports, and remove the exhaust pipe front.

13. REMOVE FRONT WHEELS

14. REMOVE FRONT WIPER ARM HEAD CAP

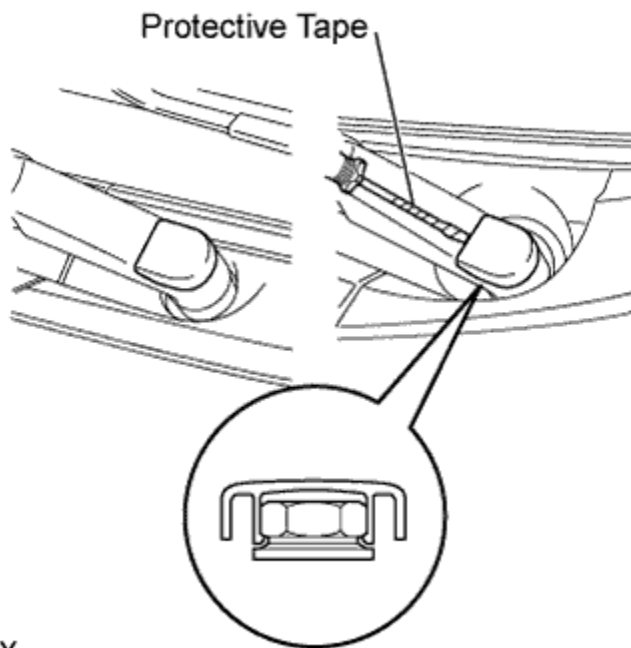

Y

1. Using a screwdriver with its tip wrapped in protective tape, disengage the claw and remove the 2 front wiper arm head caps.

15. REMOVE FRONT WIPER ARM AND BLADE ASSEMBLY LH

1. Operate the wiper, then stop the windshield wiper motor in the automatic stop position.

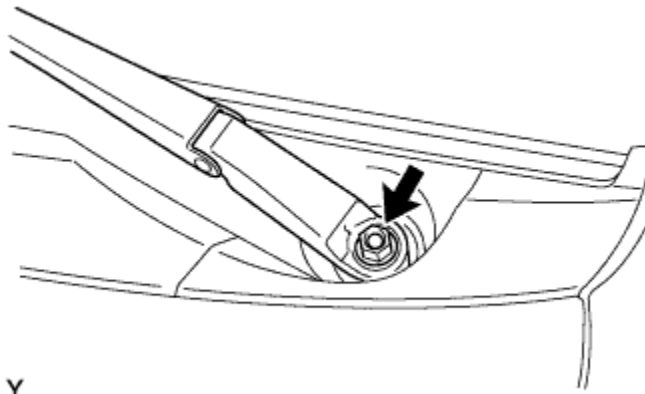

2. Remove the nut and front wiper arm.

16. REMOVE FRONT WIPER ARM AND BLADE ASSEMBLY RH

HINT:

Use the same procedure as for the LH side.

17. REMOVE HOOD TO COWL TOP SEAL

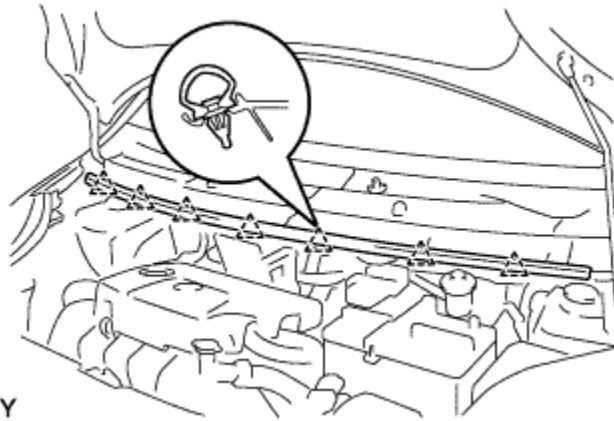

1. Disengage the 7 clips and remove the hood to cowl top seal.

18. REMOVE COWL TOP VENTILATOR LOUVER SUB-ASSEMBLY (for LHD)

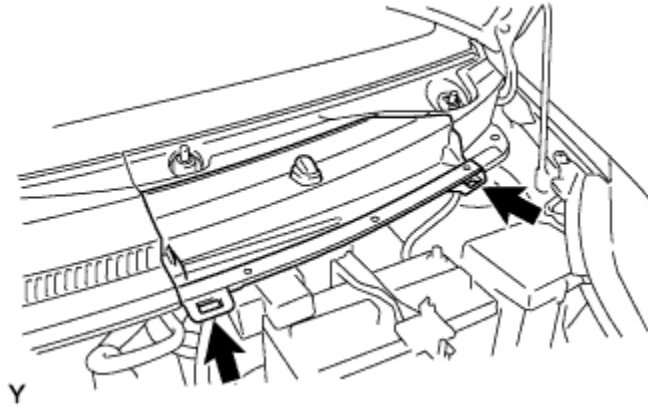

1. Disengage the 2 hooks and remove cowl top ventilator louver center No. 1.

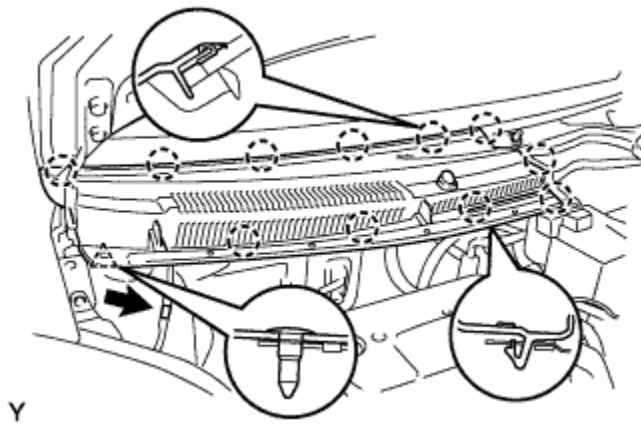

2. Disconnect the washer hose.
3. Disengage the 11 claws and clip.

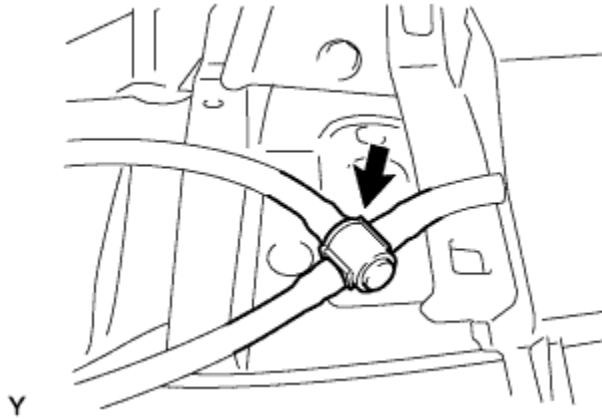

4. Disconnect the washer hose and remove the cowl top ventilator louver sub-assembly.

19. REMOVE COWL TOP VENTILATOR LOUVER LH (for LHD)

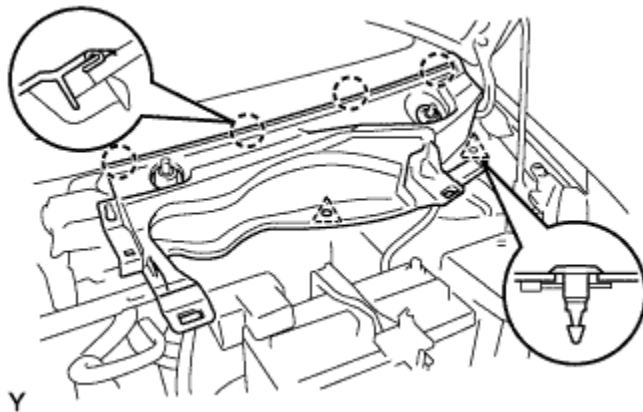

1. Remove the 2 clips.
2. Disengage the 4 claws and remove the cowl top ventilator louver LH.

20. REMOVE COWL TOP VENTILATOR LOUVER SUB-ASSEMBLY (for RHD)

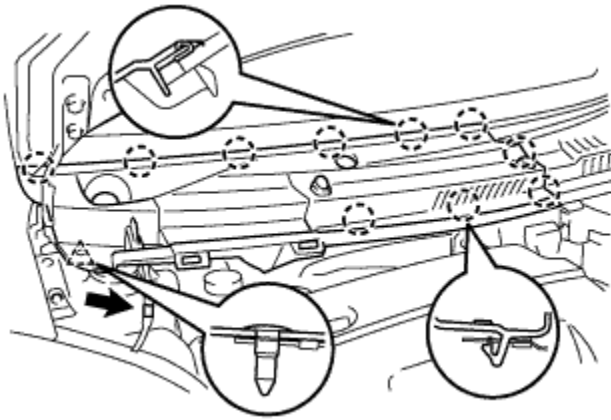

Y

1. Disconnect the washer hose.
2. Disengage the 10 claws and clip and remove the cowl top ventilator louver sub-assembly.

| |
|--|
| 21. REMOVE COWL TOP VENTILATOR LOUVER LH (for RHD) |
|--|

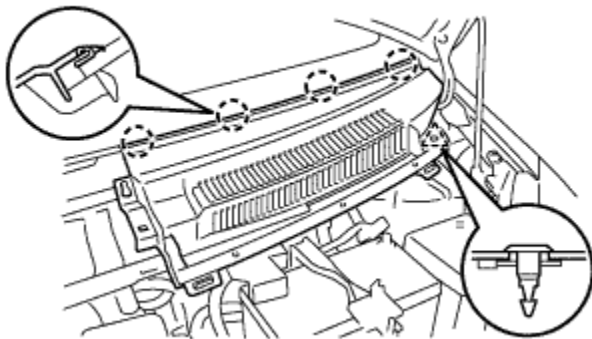

Y

1. Remove the clip.
2. Disengage the 4 claws and remove the cowl top ventilator louver LH.

22. REMOVE FRONT WIPER MOTOR AND LINK ASSEMBLY

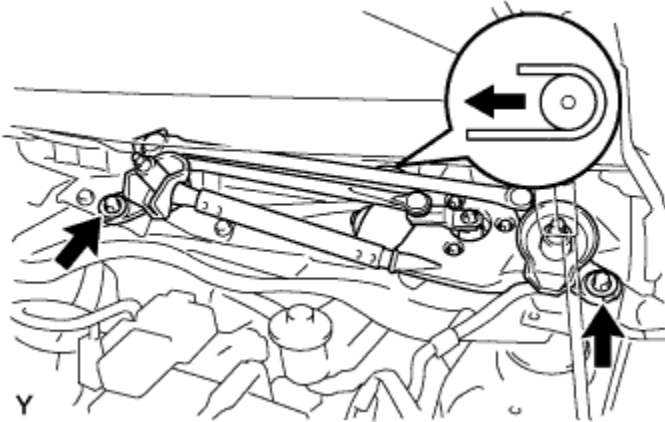

1. Remove the 2 bolts.
2. Slide the wiper link. Disengage the meshing of the rubber pin, then disconnect the connector and remove the front wiper motor and link.

23. REMOVE COWL TO REGISTER DUCT SUB-ASSEMBLY NO. 2

for LHD:

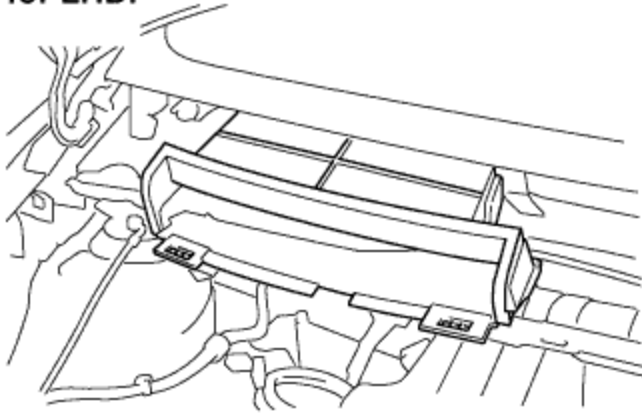

for RHD:

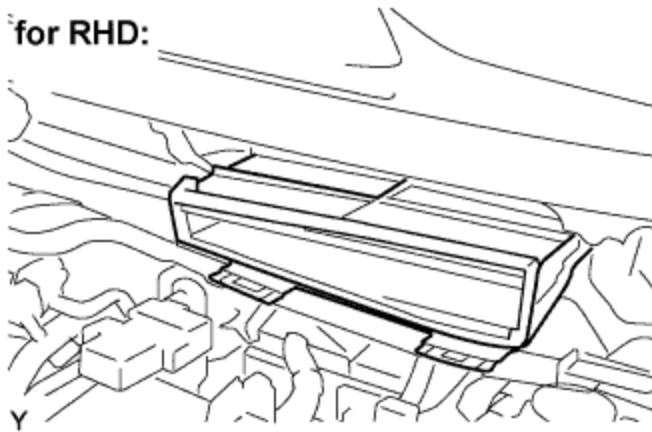

1. Disengage the claws, and remove the cowl to resistor duct No. 2.

24. REMOVE COWL TOP PANEL OUTER

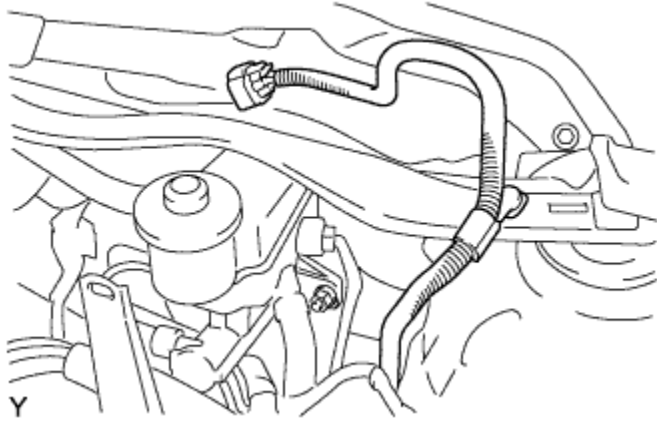

1. Disengage the clamp, and separate the wiper motor connector.

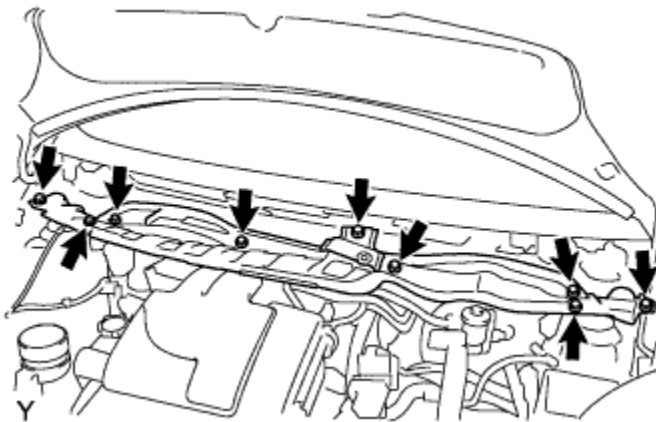

2. Remove the 9 bolts and the cowl top panel outer.

25. REMOVE AIR CLEANER CAP SUB-ASSEMBLY

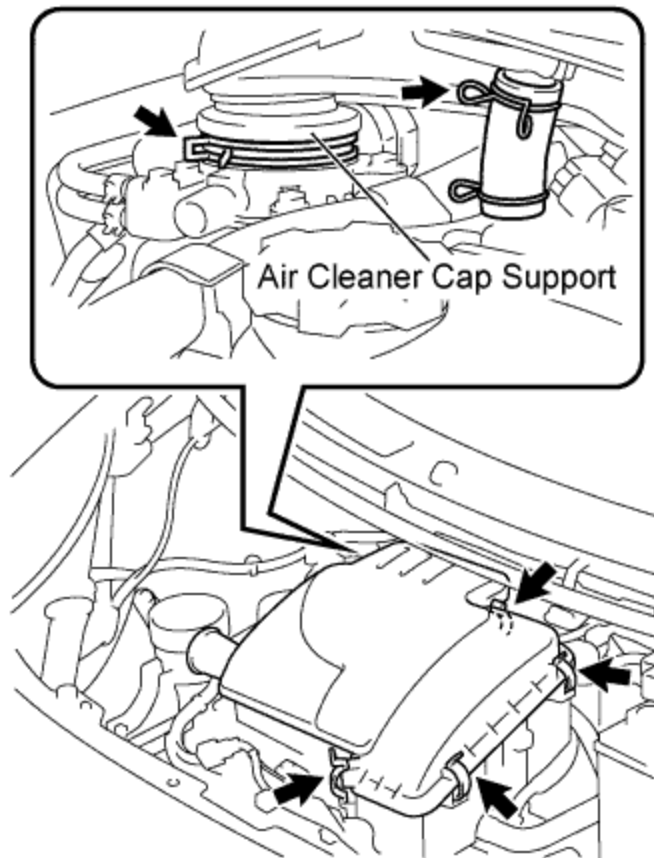

Y

1. Remove the 4 clamps.
2. Remove the 2 clamps and remove the air cleaner cap.

26. REMOVE AIR CLEANER FILTER ELEMENT SUB-ASSEMBLY

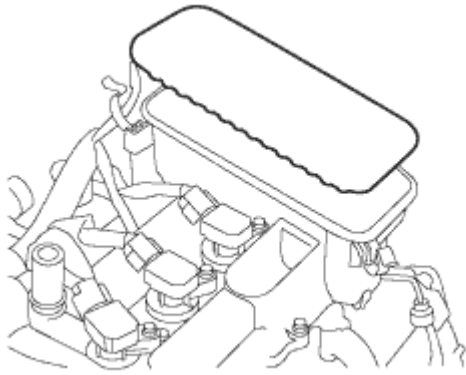

1. Remove the air cleaner filter element from the cylinder head cover.

27. REMOVE VENTILATION HOSE NO. 2

28. REMOVE FAN AND GENERATOR V BELT

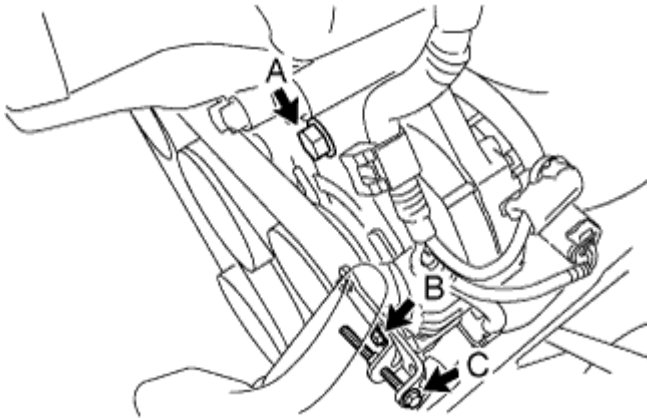

1. Loosen bolt A.
2. Loosen bolt B.
3. Loosen bolt C.
4. Release the drive belt tension and remove the fan and generator V belt.

29. REMOVE GENERATOR ASSEMBLY

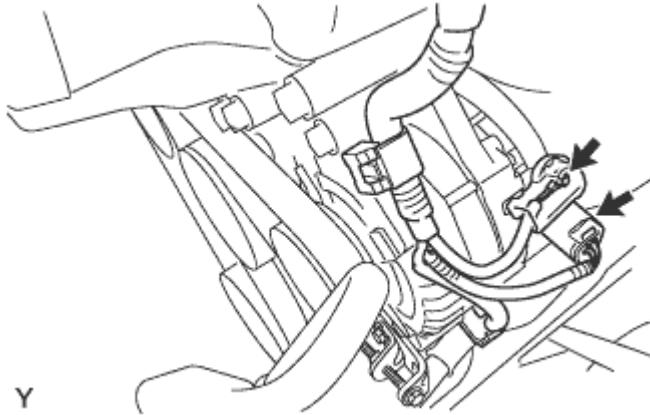

1. Disconnect the connector.
2. Remove the terminal cap.
3. Remove the nut and separate terminal B.
4. Disengage the 2 clamps and separate the wire harness.

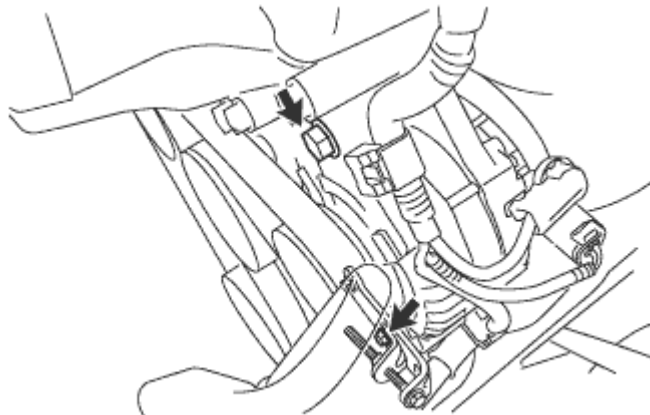

5. Remove the 2 bolts and the generator.

30. REMOVE FAN BELT ADJUSTING BAR

1. Remove the bolt and the fan belt adjusting bar.

31. DISCONNECT FUEL VAPOR FEED HOSE NO. 1



1. Disconnect the fuel vapor feed hose from the vacuum switching valve.

32. SEPARATE CLUTCH RELEASE CYLINDER ASSEMBLY

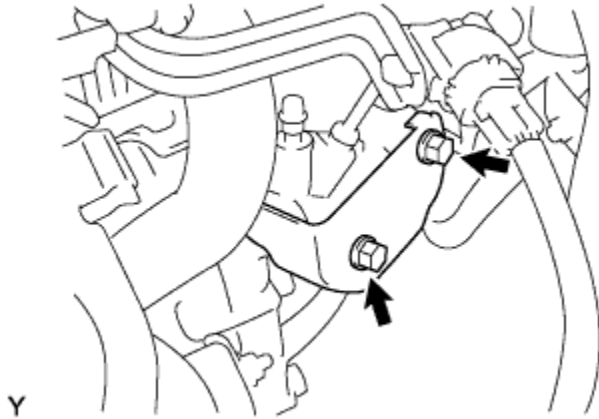

1. Remove the 2 bolts and the release cylinder heat insulator.

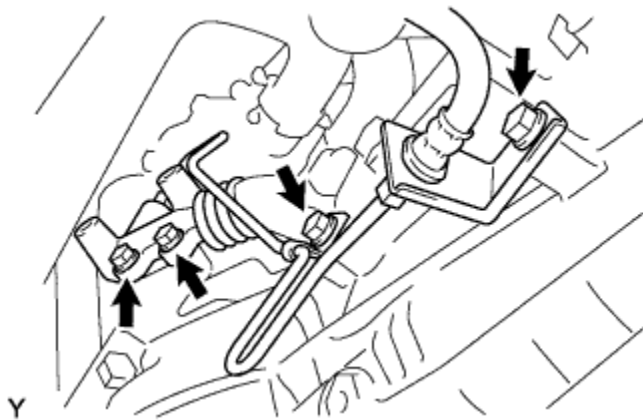

2. Remove the 4 bolts then separate the clutch release cylinder.

HINT:

Using a piece of rope or the equivalent, hang the clutch release cylinder so as not to apply excessive load to the clutch pipe.

33. SEPARATE TRANSMISSION CONTROL CABLE ASSEMBLY

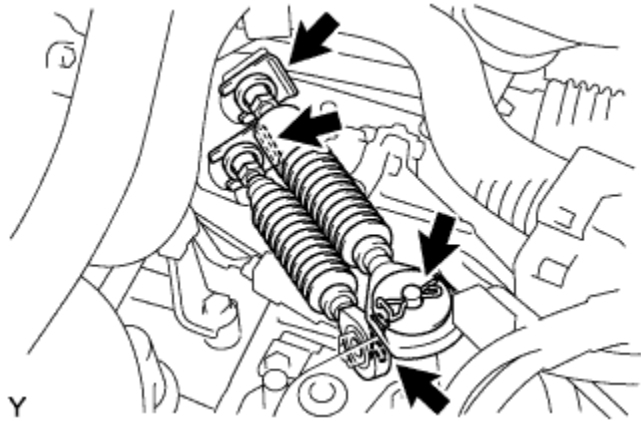

1. Remove the 2 clips and the 2 washers, and disconnect the 2 cables from the transaxle.
2. Remove the 2 clips and disconnect the 2 cables from the control cable bracket.

34. DISCONNECT BOOSTER VACUUM TUBE

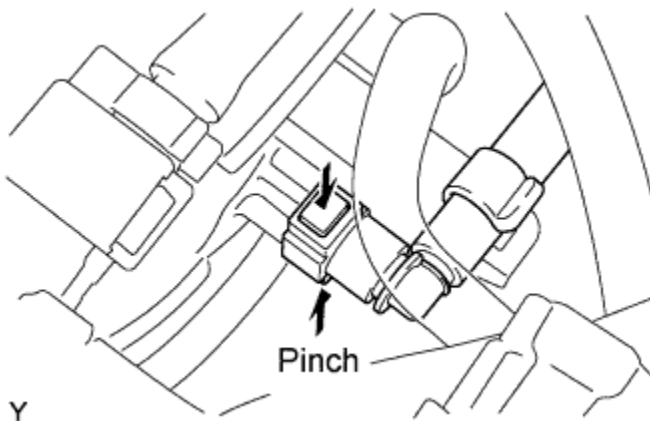

1. Pinch the retainer as illustrated, then pull the vacuum hose connector out of the pipe.

35. DISCONNECT RADIATOR HOSE NO. 1

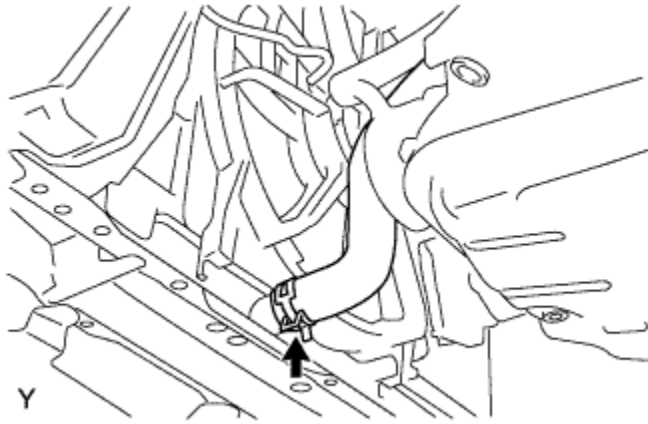

36. DISCONNECT RADIATOR HOSE NO. 2

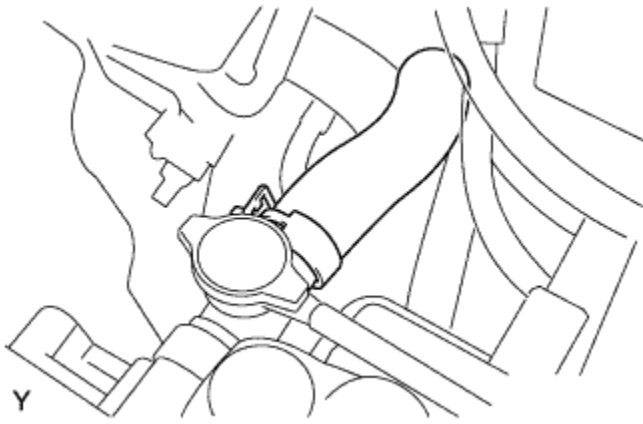

37. DISCONNECT HEATER WATER OUTLET HOSE A(FROM HEATER UNIT)

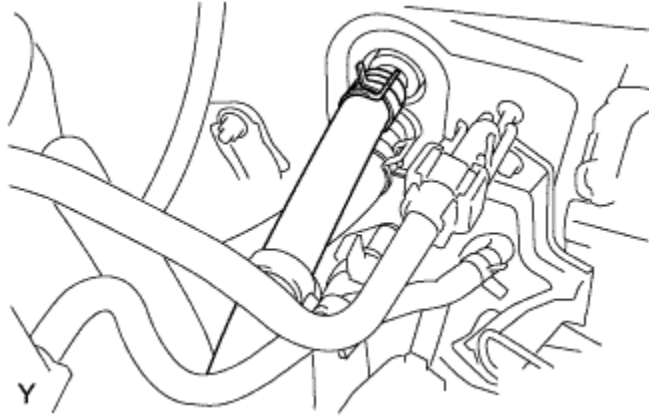

38. DISCONNECT HEATER WATER INLET HOSE A

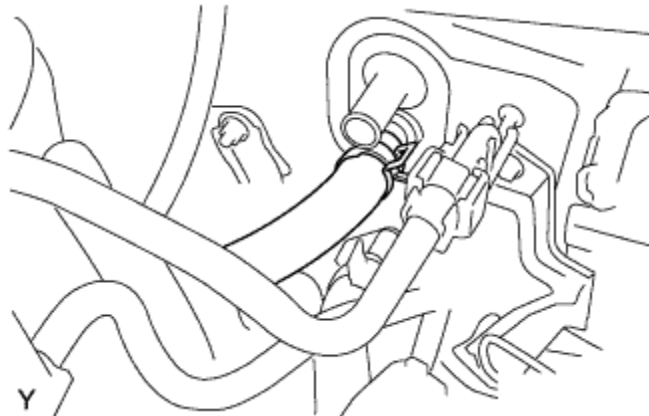

39. SEPARATE FUEL TUBE SUB-ASSEMBLY

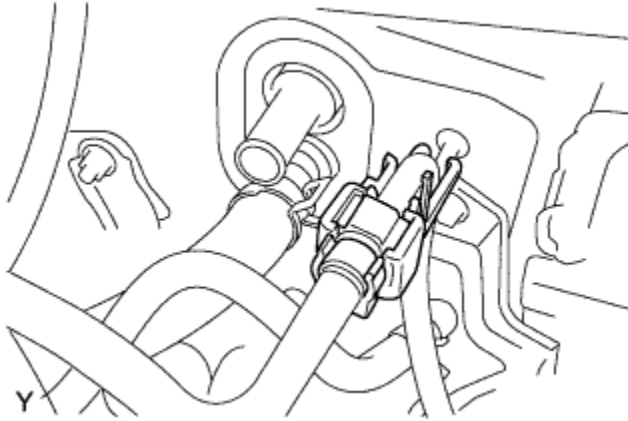

1. Remove the fuel pipe clamp No. 1.

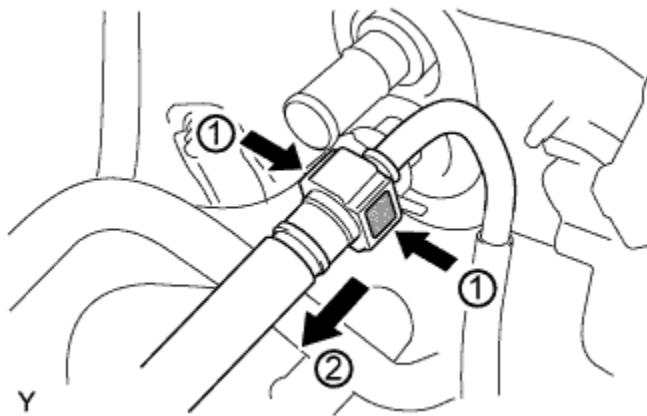

2. Pinch the retainer as illustrated, then pull the fuel tube connector out of the pipe.

NOTICE:

- Remove any dirt and foreign matter from the fuel tube connector before performing this work.
- Do not allow any scratches or foreign matter onto the parts when disconnecting, as the fuel tube connector has the O-rings that seals the pipe.
- Perform this work by hand. Do not use any tools.
- Do not forcibly bend, twist or turn the nylon tube.
- Protect the disconnected part by covering it with a vinyl bag after disconnecting the fuel tube.
- If the fuel tube connector and pipe are stuck, push and pull to release them.

40. REMOVE FRONT AXLE SHAFT LH NUT

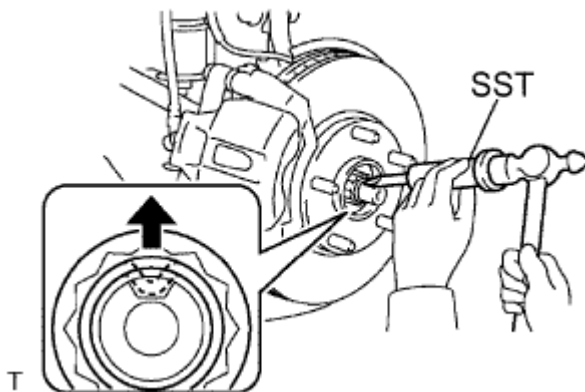

1. Using SST and a hammer, release the staked part of the axle hub nut.

SST
09930-00010

NOTICE:

- Insert SST into the groove with the flat surface facing up.
- Do not damage the tip of SST using grinders.
- Completely unstake the staked part before removing the axle hub nut.
- Do not damage the threads of the drive shaft.

2. Using a 30 mm socket wrench, remove the axle hub nut.

41. REMOVE FRONT AXLE SHAFT RH NUT

HINT:

The removal procedure for the RH side is the same as that for the LH side.

42. SEPARATE SPEED SENSOR FRONT LH

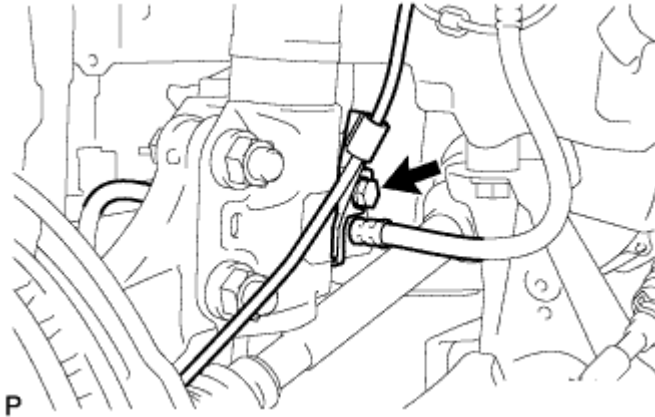

1. Remove the bolt and separate the speed sensor and flexible hose.

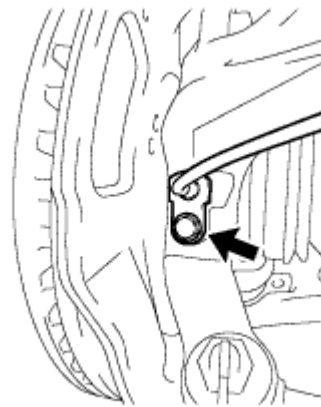

2. Remove the bolt and separate the speed sensor from the steering knuckle.

NOTICE:

- Keep the speed sensor tip and installation portion free of foreign matter.
- Remove the speed sensor without turning it from its original installation angle.

43. SEPARATE SPEED SENSOR FRONT RH

HINT:

The separation procedure for the RH side is the same as that for the LH side.

44. SEPARATE FRONT SUSPENSION ARM SUB-ASSEMBLY LOWER NO. 1 LH

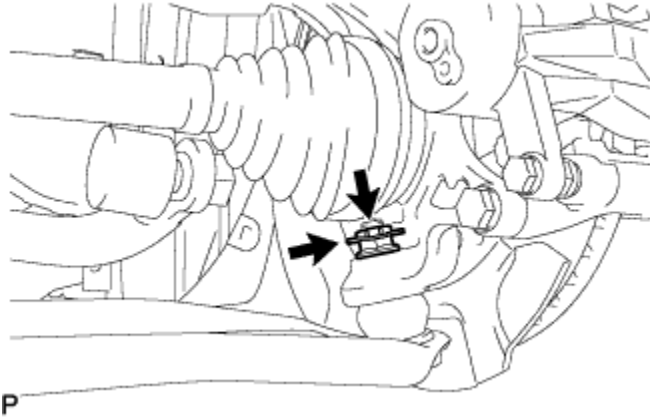

1. Remove the clip and castle nut.

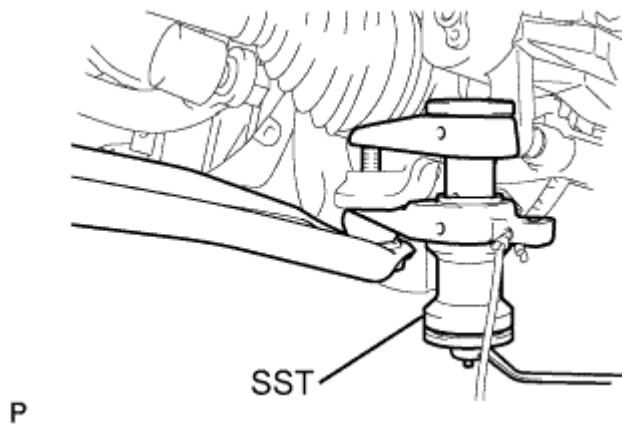

2. Using SST, separate the lower arm.

SST
09628-00011
NOTICE:

- Do not damage the lower ball joint dust cover.
- Suspend SST with a piece of string or the equivalent.

45. SEPARATE FRONT SUSPENSION ARM SUB-ASSEMBLY LOWER NO. 1 RH

HINT:

The separation procedure for the RH side is the same as that for the LH side.

46. SEPARATE TIE ROD END SUB-ASSEMBLY LH

1. Remove the cotter pin and castle nut.

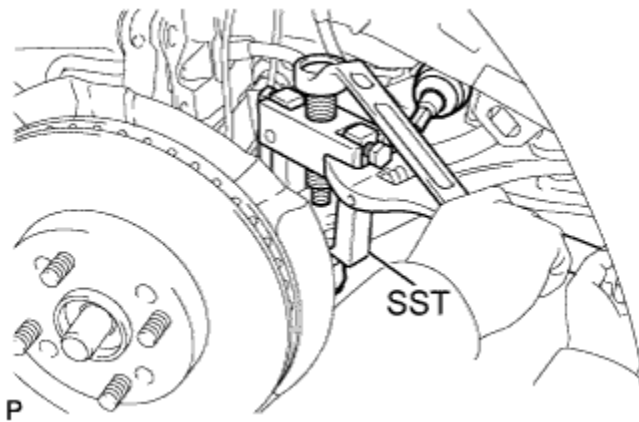

2. Using SST, separate the tie rod end from the steering knuckle.

SST

09628-62011

NOTICE:

Do not damage the tie rod end dust cover.

47. SEPARATE TIE ROD END SUB-ASSEMBLY RH

HINT:

The separation procedure for the RH side is the same as that for the LH side.

48. SEPARATE FRONT STABILIZER LINK ASSEMBLY LH

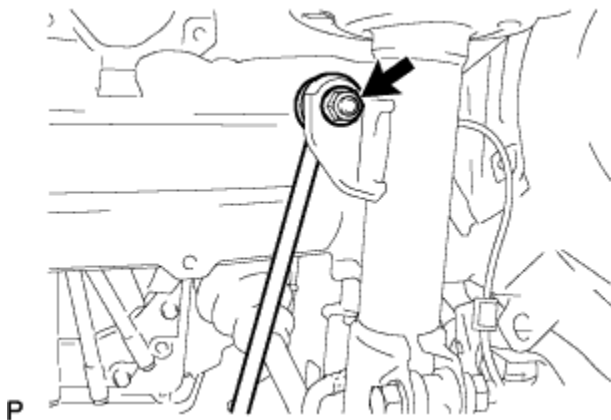

1. Remove the nut and separate the stabilizer link from the shock absorber.

HINT:

If the ball joint turns together with the nut, use a socket hexagon wrench 6 to hold the stud.

49. SEPARATE FRONT STABILIZER LINK ASSEMBLY RH

HINT:

The separation procedure for the RH side is the same as that for the LH side.

50. SEPARATE FRONT AXLE ASSEMBLY LH

1. Using a plastic hammer, tap the end of the drive shaft and disengage the fitting between the drive shaft and front axle.

HINT:

If it is difficult to disengage the fitting, tap the end of the drive shaft with a brass bar and hammer.

2. Push the front axle out of the vehicle to remove the drive shaft from the front axle.

NOTICE:

- Do not push the front axle further out of the vehicle than is necessary.
- Do not damage the outboard joint boot.

- Do not damage the speed sensor rotor.
- Suspend the drive shaft with a piece of string or the equivalent.

51. SEPARATE FRONT AXLE ASSEMBLY RH

HINT:

The separation procedure for the RH side is the same as that for the LH side.

52. REMOVE FRONT DRIVE SHAFT ASSEMBLY LH

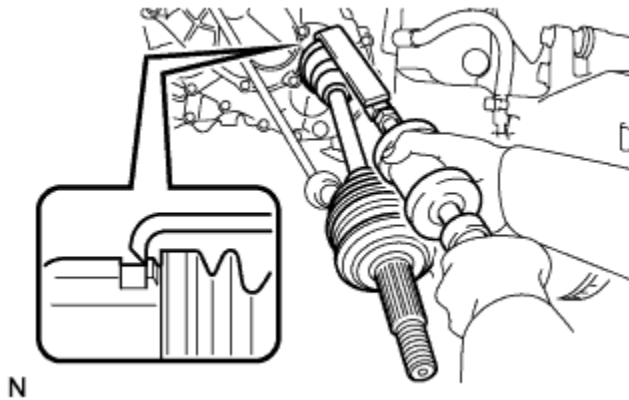

1. Using SST, remove the drive shaft.

SST

09520-01010

09520-24010 (09520-32040)

NOTICE:

- Do not damage the oil seal.
- Do not damage the inboard joint boot.
- Do not drop the drive shaft.

53. REMOVE FRONT DRIVE SHAFT ASSEMBLY RH

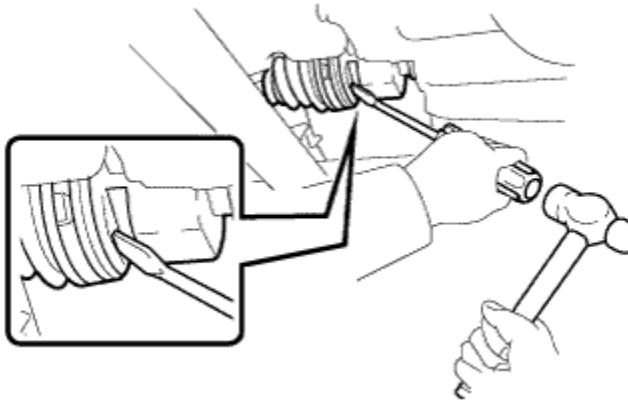

1. Using a screwdriver and hammer, remove the drive shaft.

NOTICE:

- Do not damage the oil seal.
- Do not damage the inboard joint boot.
- Do not drop the drive shaft.

54. REMOVE COLUMN HOLE COVER SILENCER SHEET

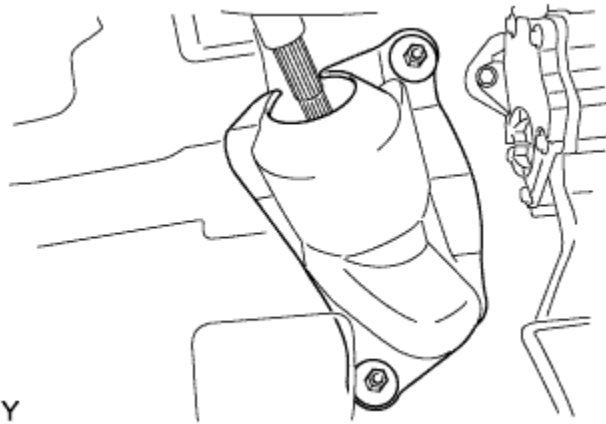

1. Remove the 2 clips and the column hole cover silencer sheet.

55. SEPARATE STEERING INTERMEDIATE SHAFT ASSEMBLY NO. 2

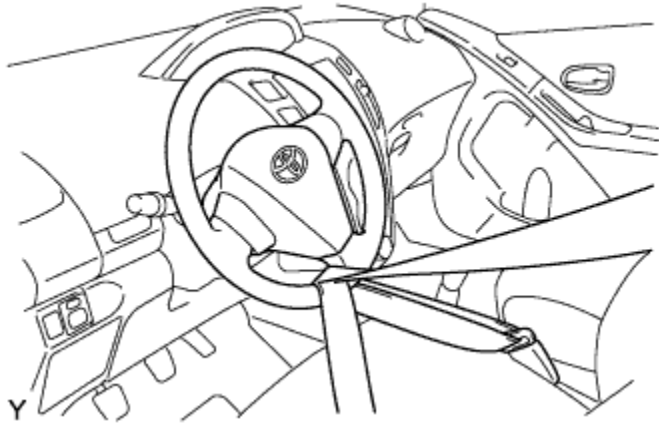

1. Hold the steering wheel with the seatbelt to avoid steering wheel rotation and damage to the spiral cable.

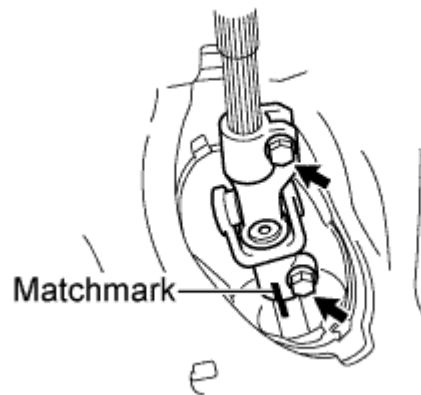

2. Put a matchmark on the sliding yoke and the intermediate shaft.
3. Loosen the 2 bolts to separate the sliding yoke.

56. REMOVE STEERING COLUMN HOLE COVER SUB-ASSEMBLY NO. 1

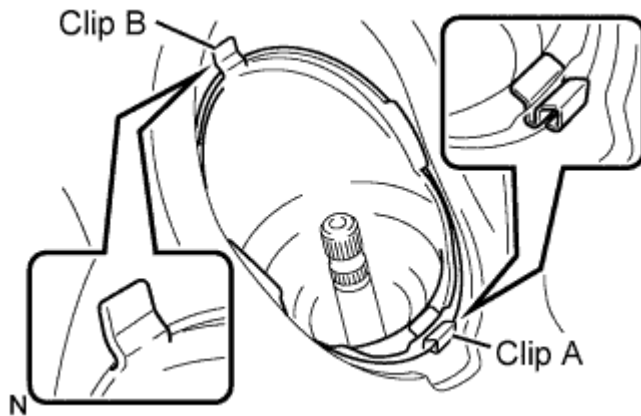

1. Remove the clip A and separate the steering column hole cover from the body.

NOTICE:
Do not damage clip B.

57. SEPARATE ECM

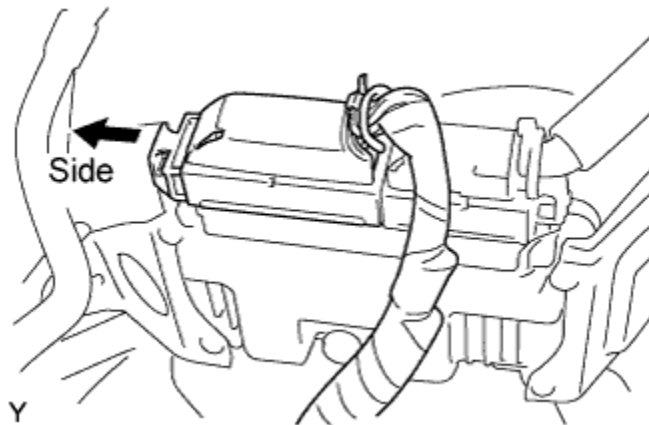

1. Move the pinch in the direction shown in the illustration and separate the connector.

58. SEPARATE ENGINE WIRE

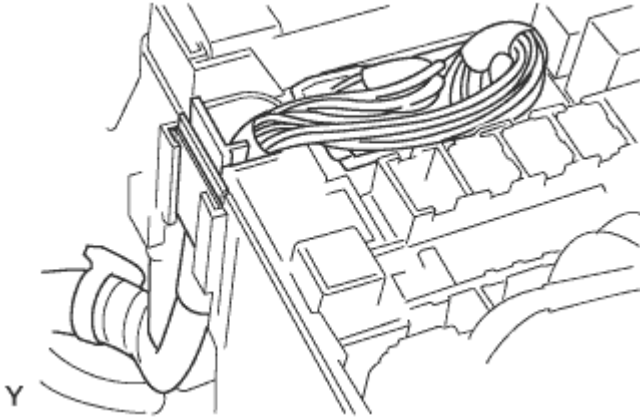

1. Remove the engine room relay block cover.
2. Disconnect the 2 connectors and disengage the wire harness clamp.

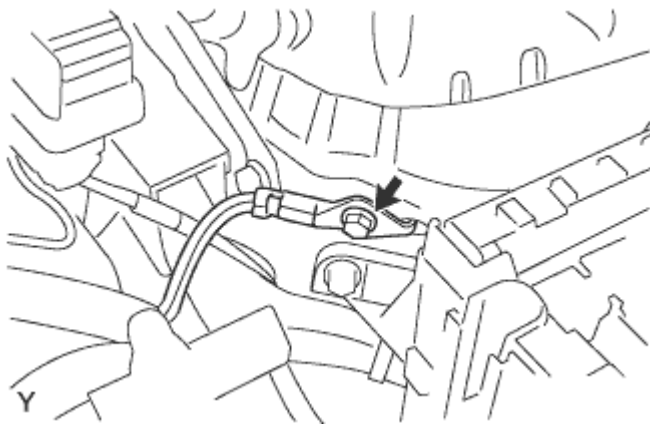

3. Remove the bolt and separate the earth wire.
4. Check that the engine wire harness is disconnected between the body and engine

59. SEPARATE WITH PULLEY COMPRESSOR ASSEMBLY (w/ Air Conditioning System)

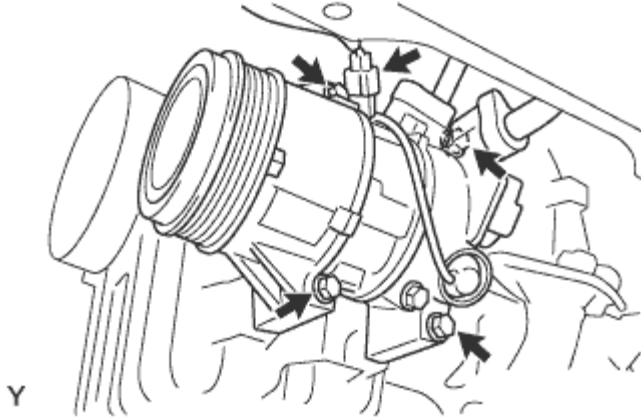

1. Disconnect the connector.
2. Remove the 4 bolts and separate the compressor.

HINT:

Secure the compressor and hoses off to the side instead of discharging the A/C system.

60. REMOVE ENGINE ASSEMBLY WITH TRANSAXLE

1. Set the engine lifter under the engine assembly with transaxle.

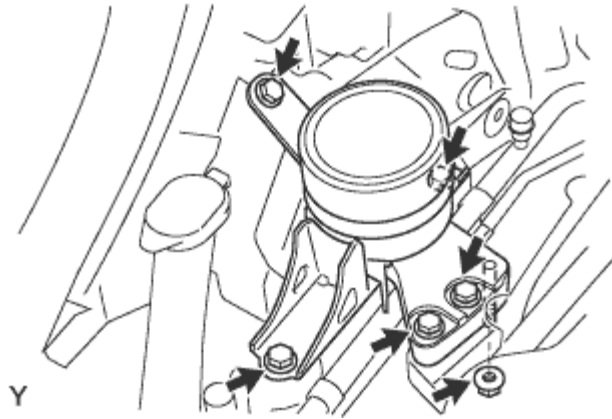

2. Remove the 5 bolts and the nut, then remove the engine mounting insulator RH.

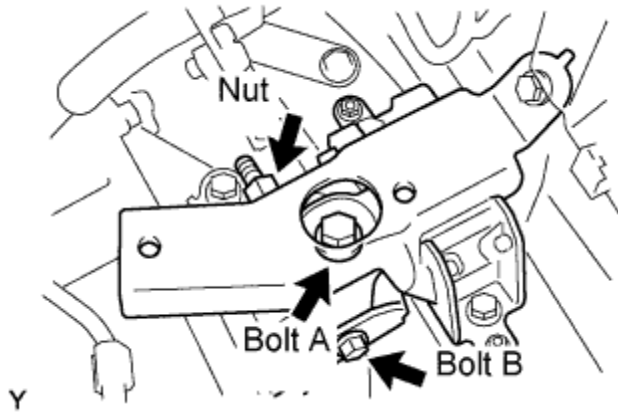

3. Remove bolt A from the engine mounting insulator LH.
4. Remove bolt B and the nut, and separate the engine mounting insulator LH.

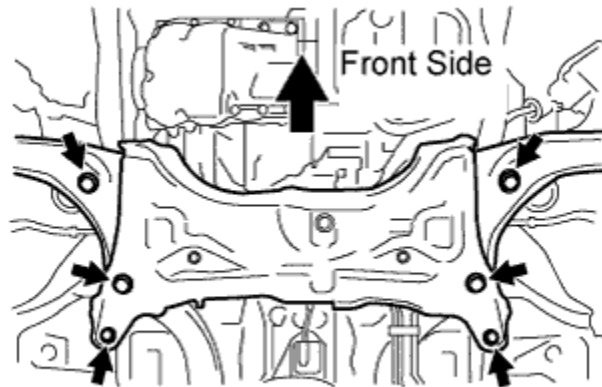

5. Remove the 6 bolts and the engine assembly with transaxle and front suspension member.

61. SUPPORT ENGINE ASSEMBLY WITH TRANSAXLE

1. Remove the bolt and separate wire harness clamp.

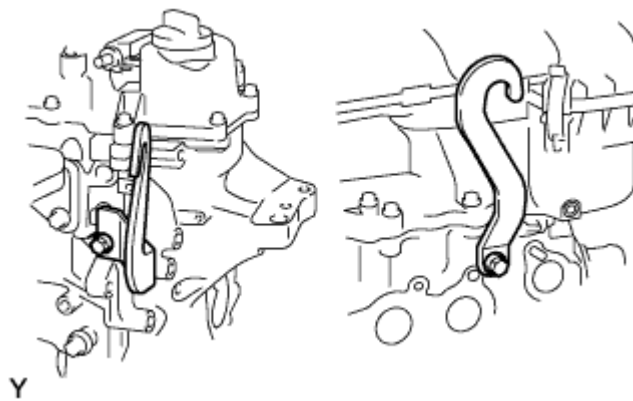

2. Install the engine hanger with the bolt.

Part No.:

No. 1 engine hanger:

12281 - 40030

No. 2 engine hanger:

12282 - 40010

Bolt:
91671 - 80820
Torque:
28 N*m { 286 kgf*cm , 21 ft.*lbf }

3. Attach the engine sling device to the engine hangers.

62. REMOVE FLYWHEEL HOUSING SIDE COVER (for 0.8 kW Type)

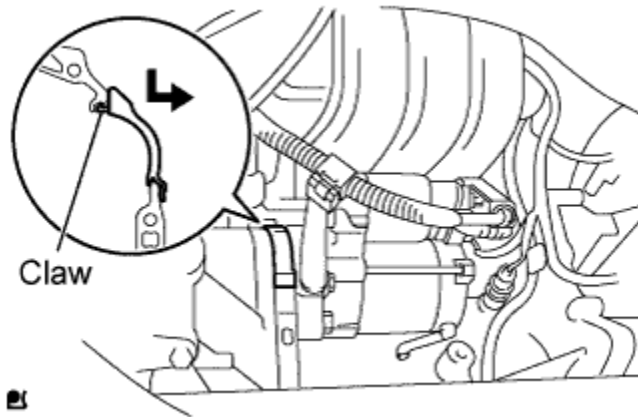

1. Disengage the claw while pushing it downward and remove the flywheel housing side cover.

63. REMOVE FLYWHEEL HOUSING SIDE COVER (for 1.0 kW Type)

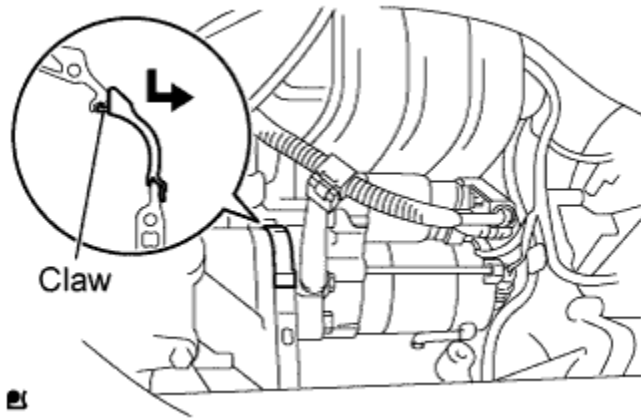

1. Disengage the claw while pushing it downward and remove the flywheel housing side cover.

64. REMOVE STARTER ASSEMBLY (for 0.8 kW Type)

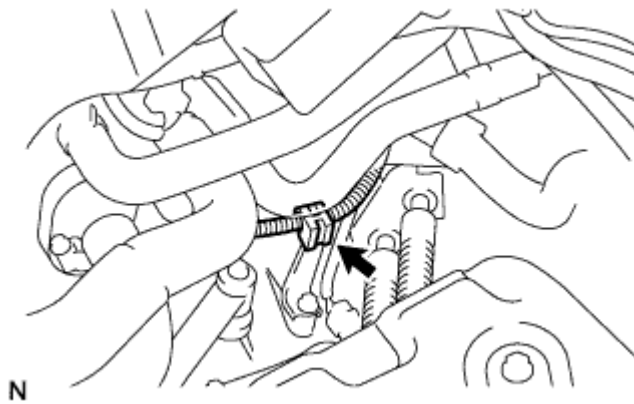

1. Separate the harness clamp.

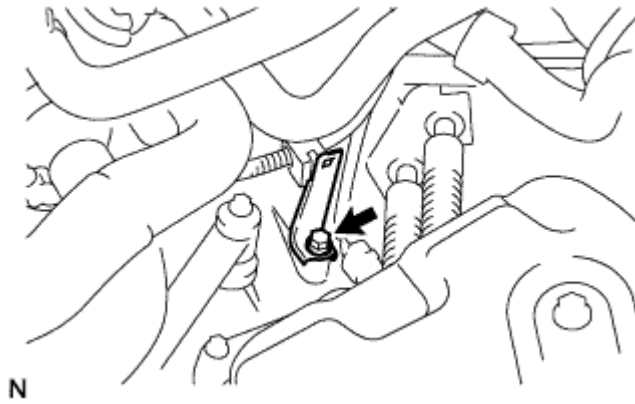

2. Remove the bolt and remove the wire harness bracket.

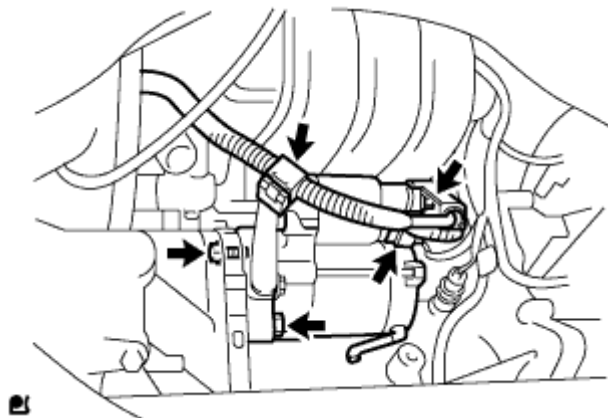

3. Remove the terminal cap.
4. Separate the harness clamp.
5. Remove the nut and disconnect terminal 30.
6. Disconnect the connector.
7. Remove the 2 bolts and remove the starter assembly.

| |
|---|
| 65. REMOVE STARTER ASSEMBLY (for 1.0 kW Type) |
|---|

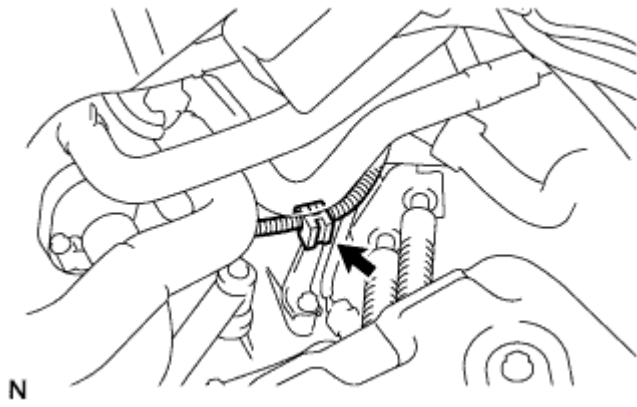

1. Separate the harness clamp.

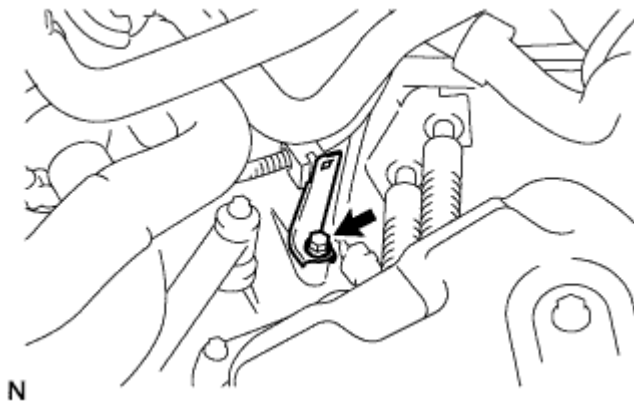

2. Remove the bolt and remove the wire harness bracket.

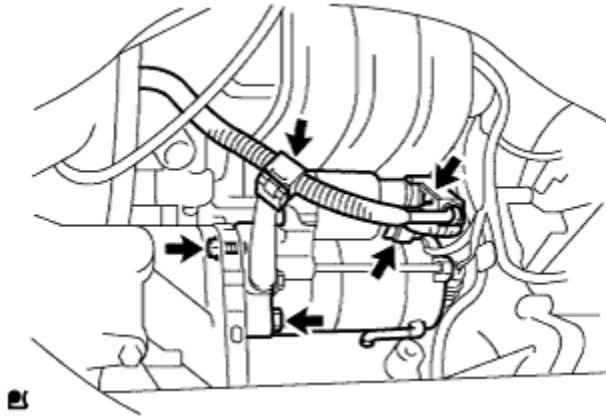

3. Remove the terminal cap.
4. Separate the harness clamp.
5. Remove the nut and disconnect terminal 30.
6. Disconnect the connector.
7. Remove the 2 bolts and remove the starter assembly.

66. SEPARATE ENGINE MOVING CONTROL ROD

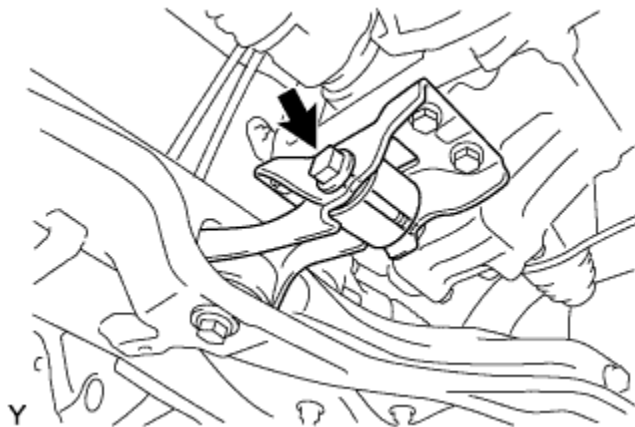

1. Remove the bolt and separate the engine moving control rod.

67. REMOVE MANUAL TRANSAXLE ASSEMBLY

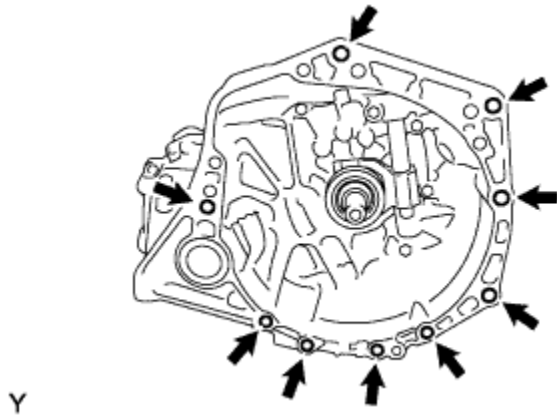

Y

1. Remove the 9 bolts and manual transaxle.

68. REMOVE CLUTCH COVER ASSEMBLY

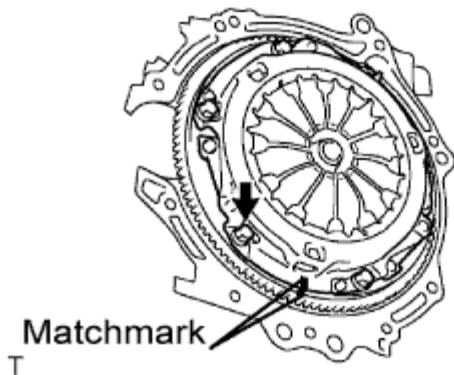

1. Align the matchmark on the clutch cover with the one on the flywheel.
2. Loosen each set bolt by one turn at a time until the spring tension is released.

3. Remove the set bolts and the clutch cover.

NOTICE:

Do not drop the clutch disc.

69. REMOVE CLUTCH DISC ASSEMBLY

NOTICE:

Keep the lining part of the clutch disc and the surfaces of the pressure plate and flywheel free of oil and foreign matter.

70. REMOVE FLYWHEEL ASSEMBLY

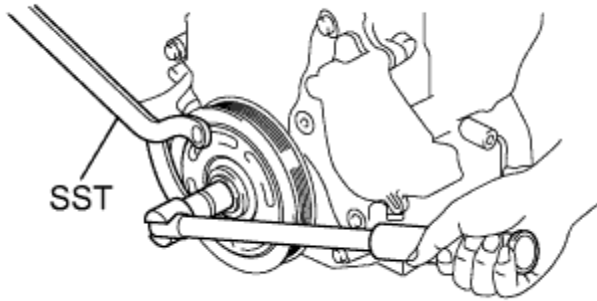

Y

1. Hold the crankshaft with SST.

SST

09960-10010 (09962-01000, 09963-01000)

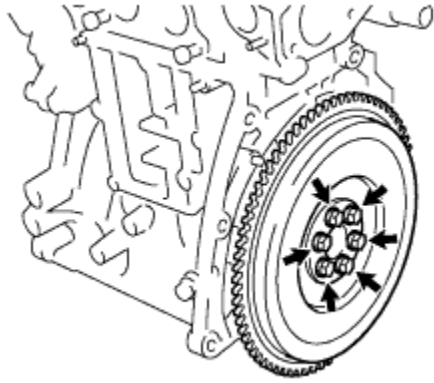

N

2. Remove the 6 bolts and the flywheel.

71. REMOVE IGNITION COIL NO. 1

1. Disconnect the 3 connectors.

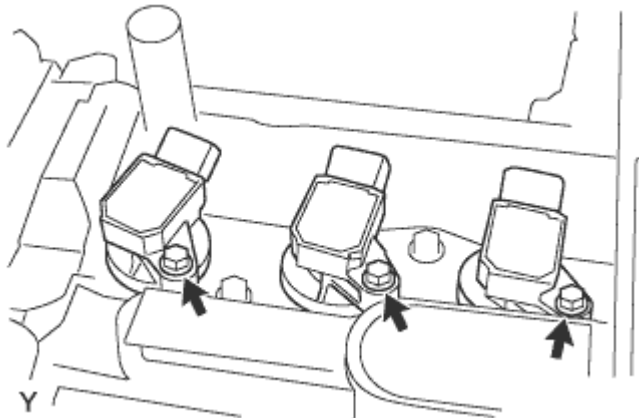

2. Remove the 3 bolts and 3 ignition coils.

72. REMOVE DUTY VACUUM SWITCHING VALVE

1. Disconnect the connector.

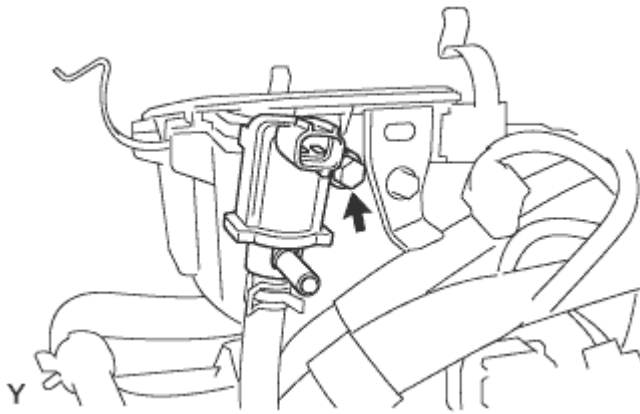

2. Remove the bolt and the duty vacuum switching valve.

73. REMOVE MANIFOLD STAY

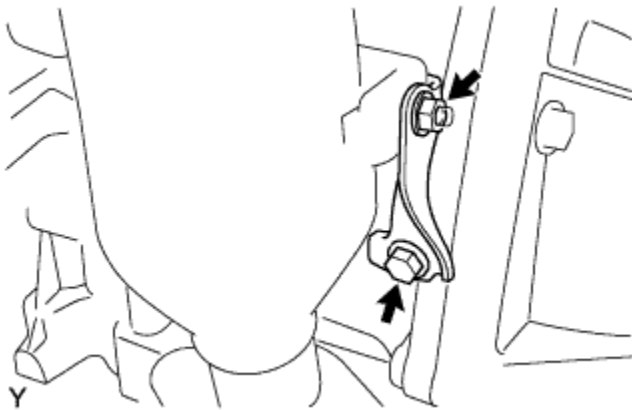

1. Remove the bolt and nut, and remove the manifold stay.

74. REMOVE EXHAUST MANIFOLD ASSEMBLY

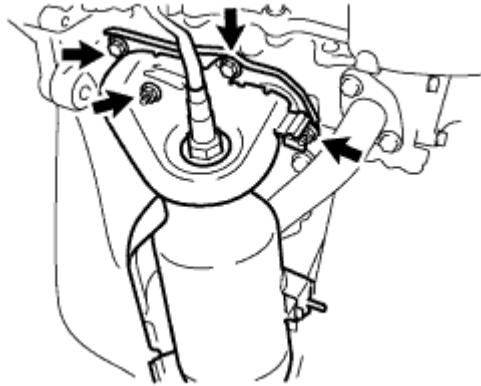

1. Remove the 2 bolts and 2 nuts.
2. Remove the exhaust manifold and gasket.

75. REMOVE THROTTLE WITH MOTOR BODY ASSEMBLY

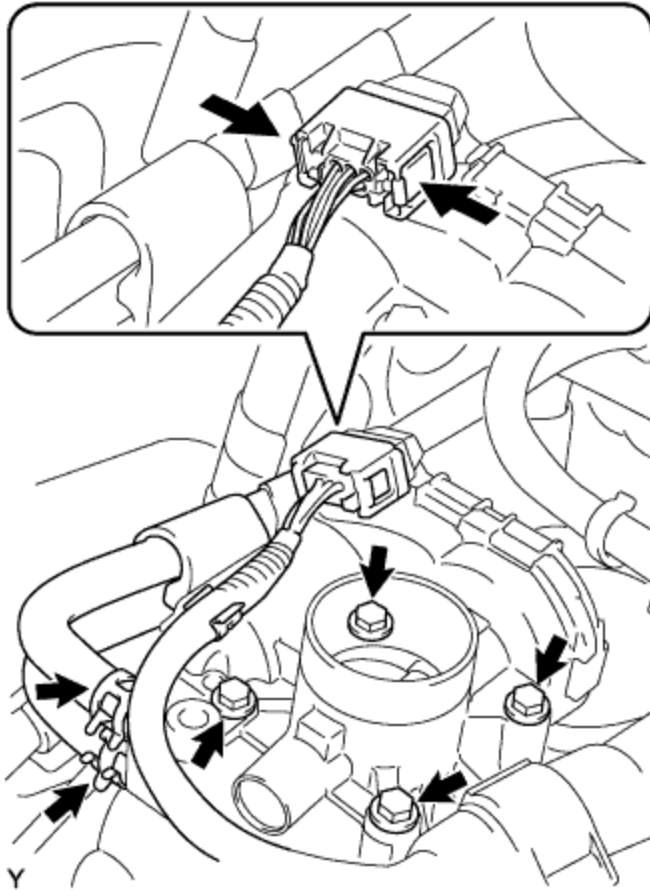

1. Pinch the connector as illustrated, then disconnect the connector.
2. Disconnect the 2 water by-pass hoses.
3. Remove the 4 bolts and the throttle body.

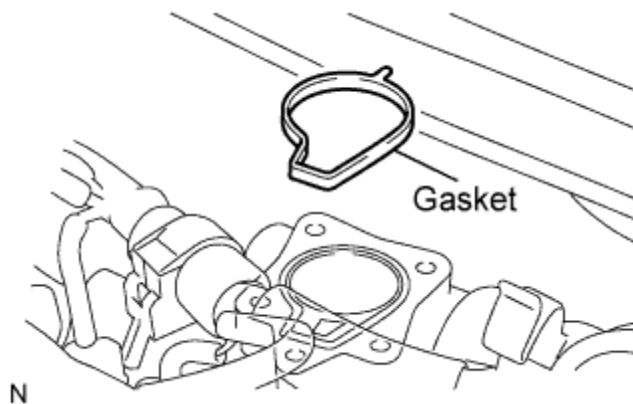

4. Remove the throttle body gasket.

76. REMOVE INTAKE MANIFOLD STAY



1. Remove the 2 bolts and the intake manifold stay.

77. REMOVE INTAKE MANIFOLD

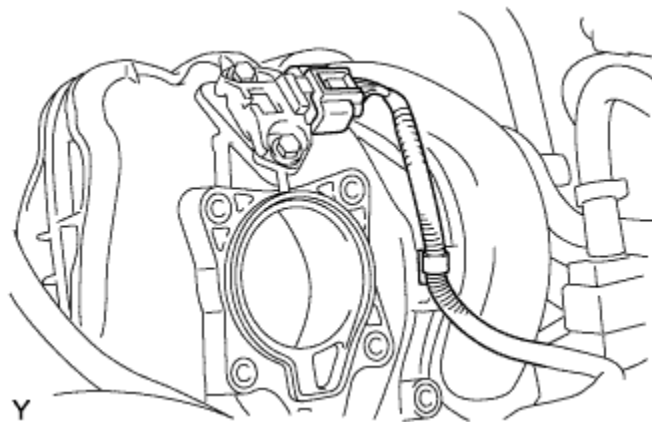

1. Disconnect the manifold absolute pressure sensor connector.

2. Separate the wire harness.

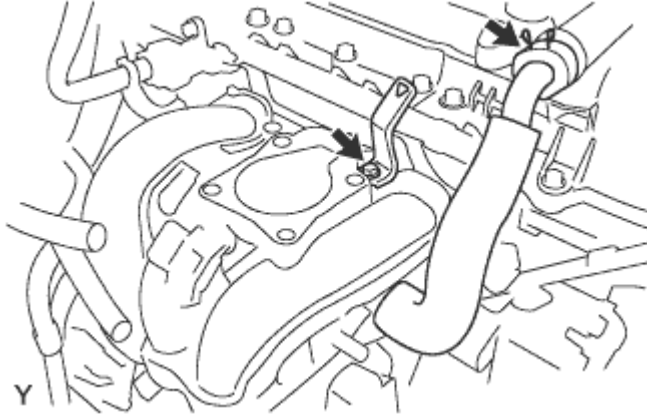

3. Remove the bolt and wire harness clamp.
4. Disconnect the ventilation hose.

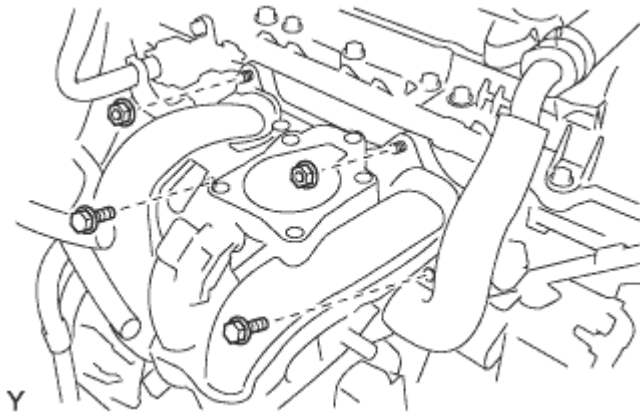

5. Remove the 2 bolts and 2 nuts.

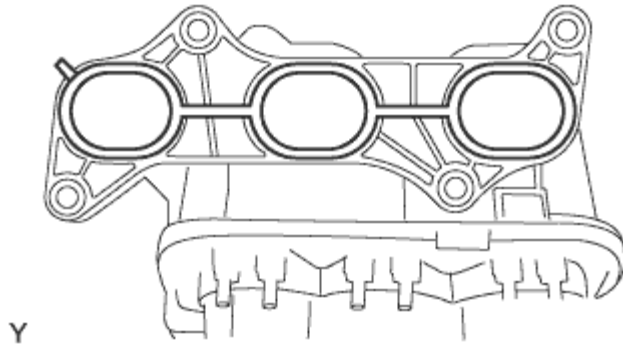

6. Remove the intake manifold and gasket.

78. REMOVE FUEL DELIVERY PIPE

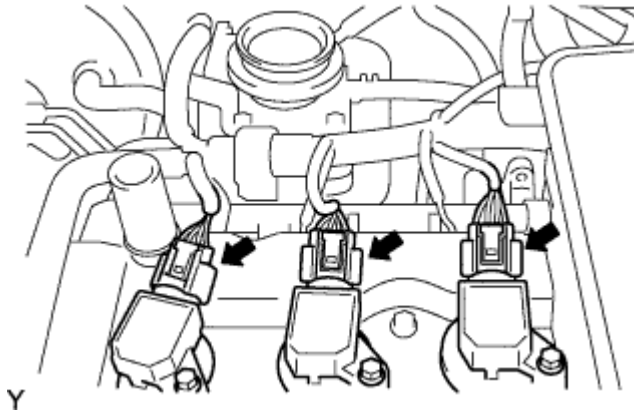

1. Disconnect the 3 ignition coil connectors.

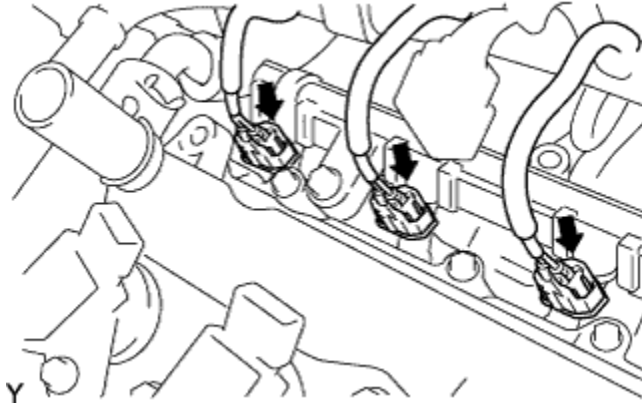

2. Disconnect the 3 injector connectors.

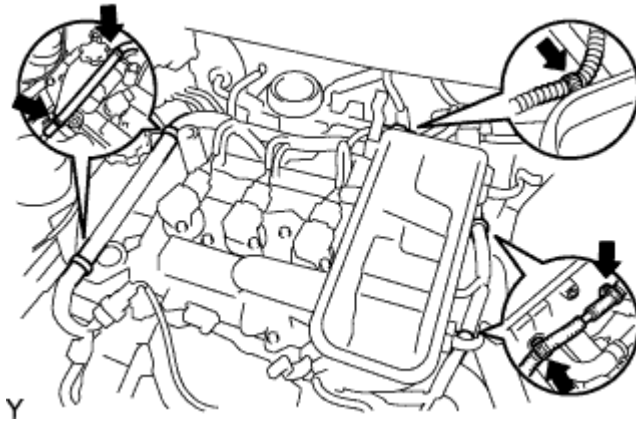

3. Disengage the 5 clamps, and separate the engine wire harness from the cylinder head cover.

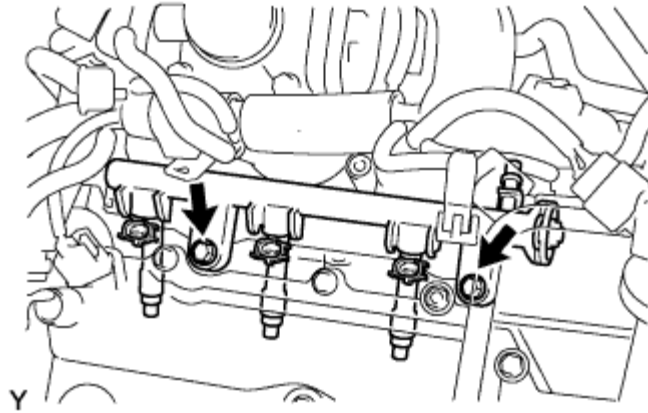

4. Remove the 2 bolts and delivery pipe together with the 3 injectors.

NOTICE:

Do not drop the injectors when removing the delivery pipe.

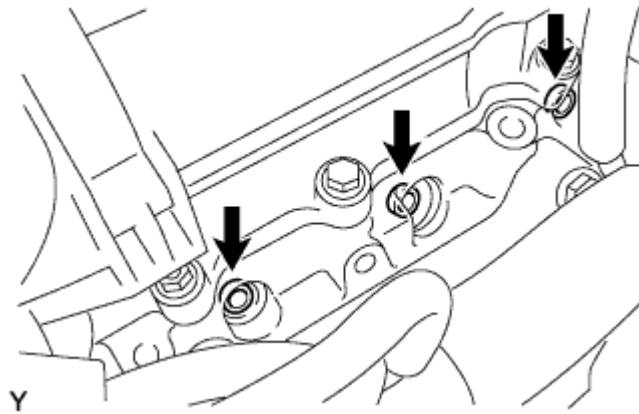

5. Remove the 3 injector vibration insulators from the cylinder head.

| |
|-----------------------------------|
| 79. REMOVE FUEL INJECTOR ASSEMBLY |
|-----------------------------------|

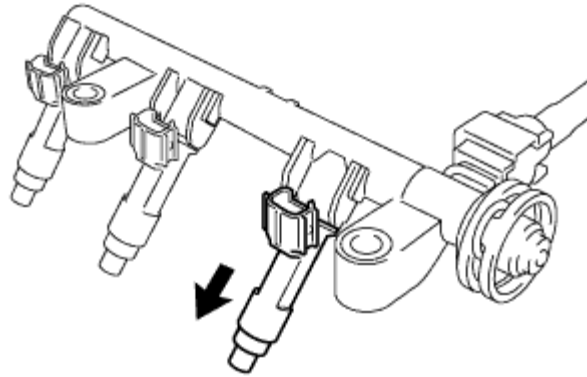

Y

1. Pull the 3 injectors out of the fuel delivery pipe.

80. REMOVE RADIO SETTING CONDENSER

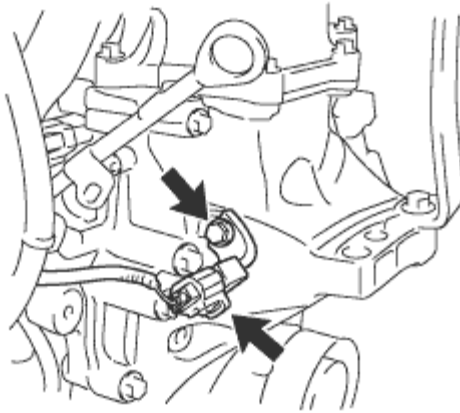

Y

1. Disconnect the connector.
2. Remove the bolt and radio setting condenser.

81. REMOVE KNOCK SENSOR

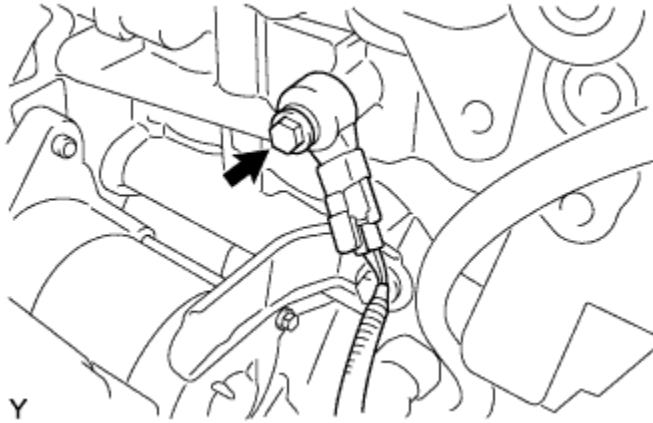

1. Disconnect the connector.
2. Remove the bolt and knock sensor.

82. REMOVE ENGINE WIRE

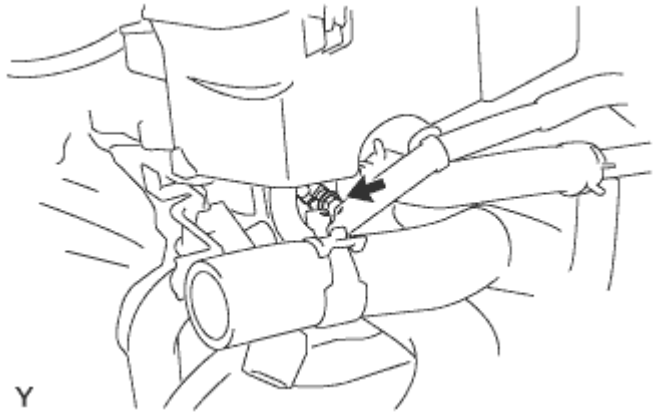

1. Remove the bolt and separate the engine wire harness.
2. Separate the wire harness clamps and remove the engine wire.

83. REMOVE HEATER WATER OUTLET HOSE A(FROM HEATER UNIT)

84. REMOVE HEATER WATER INLET HOSE A

85. REMOVE RADIATOR HOSE NO. 1

86. REMOVE RADIATOR HOSE NO. 2

ENGINE ASSEMBLY > REMOVAL

1. CLUTCH POSITION ADJUSTMENT (for Multi-Mode Manual Transaxle)

()

2. DISCHARGE FUEL SYSTEM PRESSURE

()

3. REMOVE BATTERY

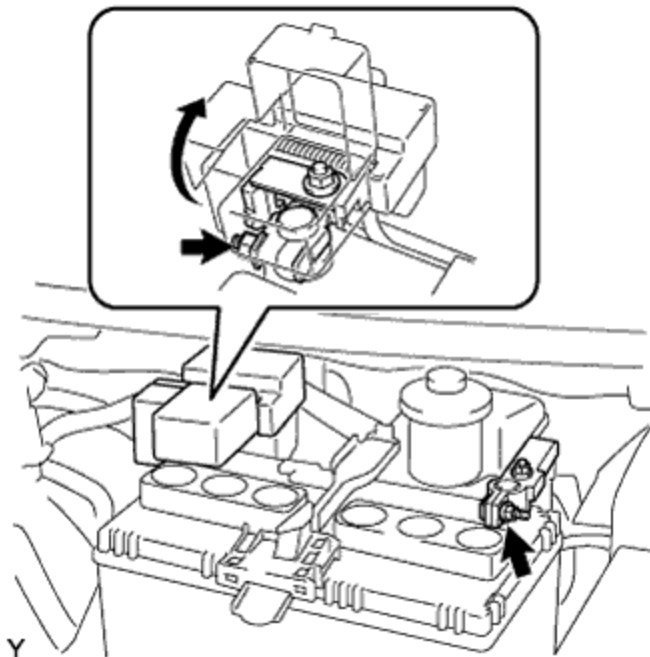

1. Disconnect the negative battery terminal.
2. Disconnect the positive battery terminal.

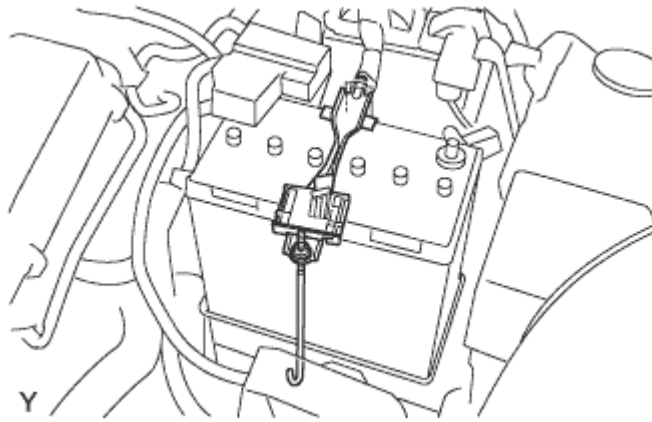

3. Loosen the nut, and remove the battery carrier clamp.
4. Remove the battery from the vehicle.

4. REMOVE BATTERY TRAY

5. REMOVE BATTERY CARRIER

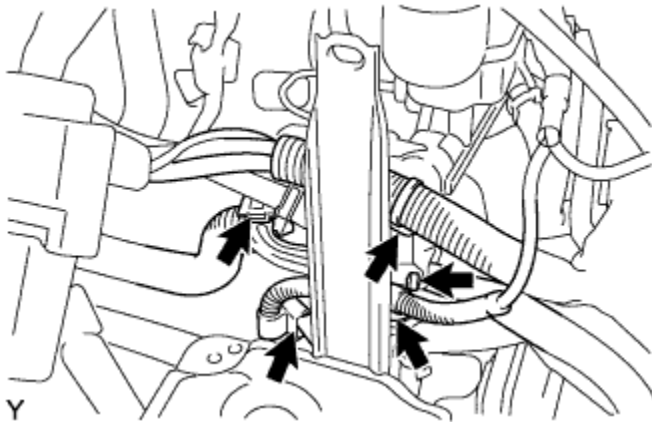

1. Disengage the 5 clamps, and separate the engine wire harness.

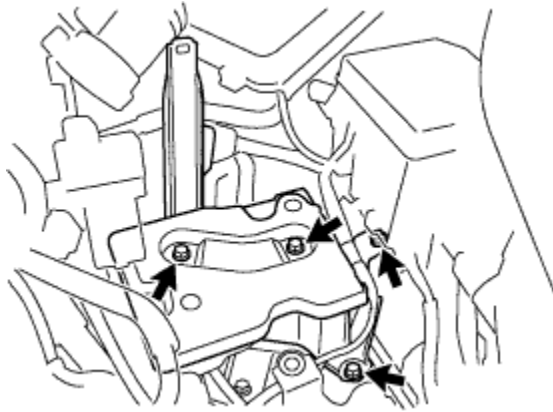

2. Remove the 4 bolts, and remove the battery carrier.

6. REMOVE FRONT SPOILER COVER LH (w/ Front Spoiler Cover LH)

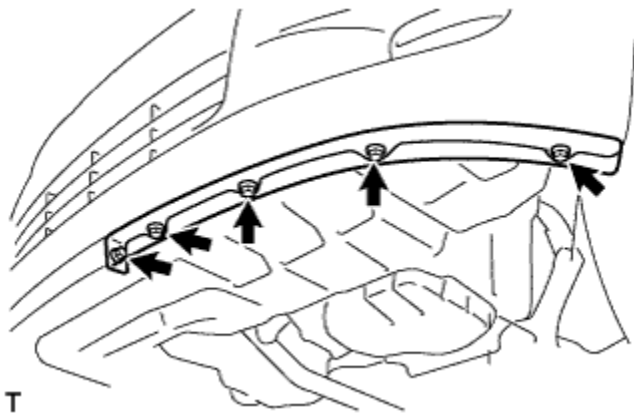

1. Remove the 5 screws and the front spoiler cover.

7. REMOVE FRONT SPOILER COVER (w/ Front Spoiler Cover)

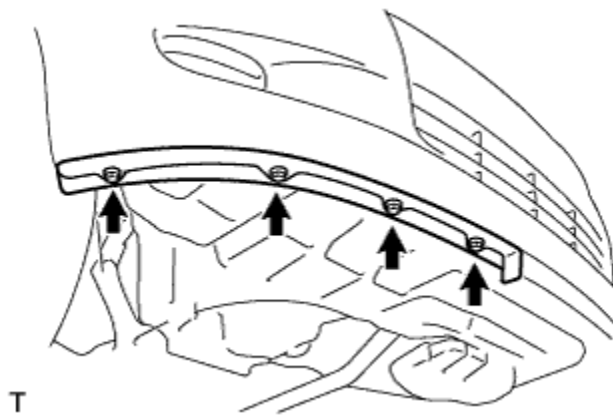

1. Remove the 4 screws and the front spoiler cover.

8. REMOVE ENGINE UNDER COVER LH

9. REMOVE ENGINE UNDER COVER RH

10. DRAIN ENGINE COOLANT

CAUTION:

To avoid the danger of being burned, do not remove the radiator cap sub-assembly while the engine and radiator assembly are still hot. Thermal expansion will cause hot engine coolant and steam to blow out from the radiator assembly.

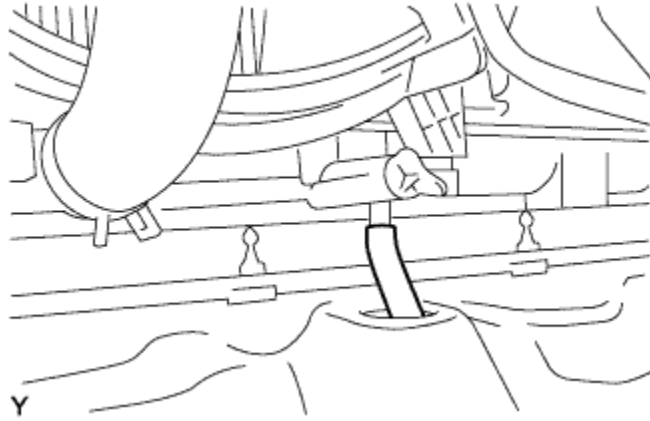

1. Install a vinyl hose onto the radiator side.
2. Loosen the radiator drain cock plug.
3. Remove the radiator cap sub-assembly.

4. Loosen the water drain plug, then drain the coolant.

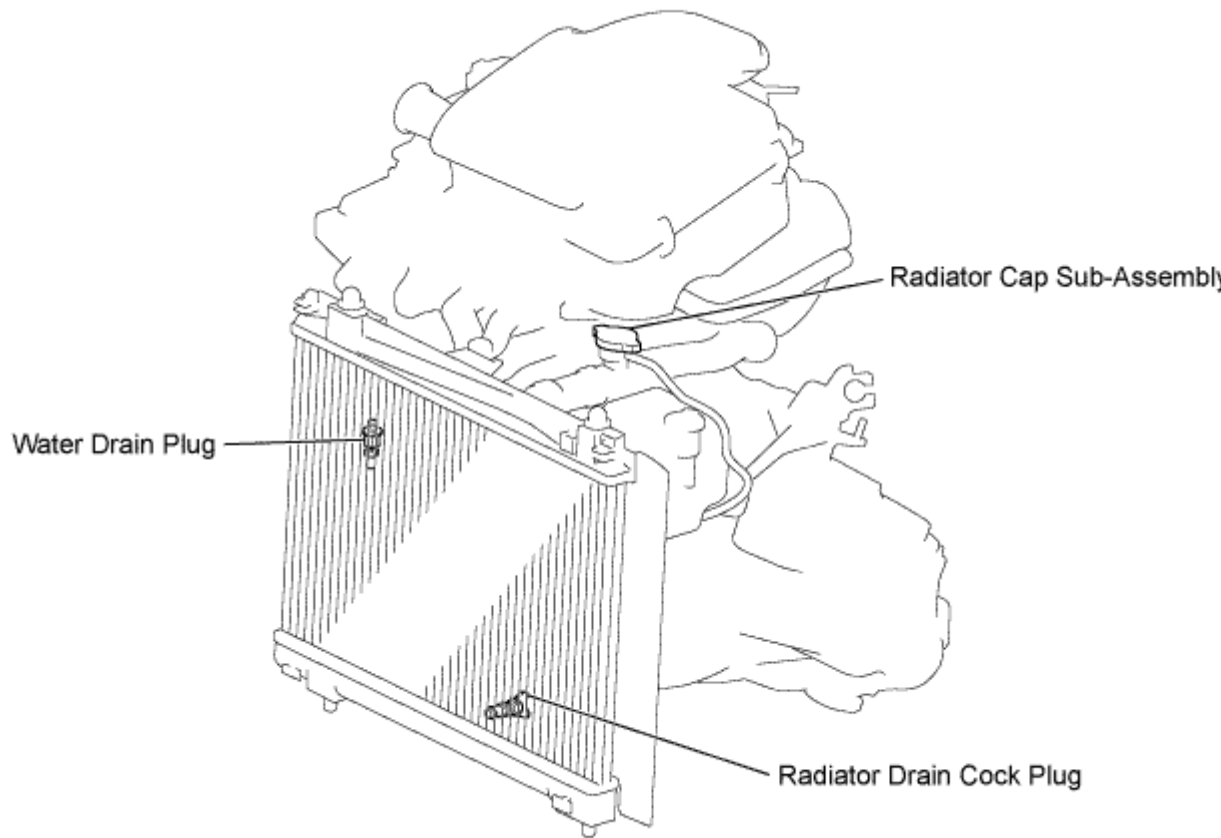

Y

11. DRAIN TRANSAXLE OIL (for Manual Transaxle)

1. Remove the filler plug and gasket.
2. Remove the drain plug and gasket, and then drain the manual transaxle oil.
3. Install a new gasket and the drain plug.

Torque:
39 N*m { 400 kgf*cm , 29 ft.*lbf }

12. DRAIN TRANSAXLE OIL (for Multi-Mode Manual Transaxle)

1. Remove the filler plug and the gasket.
2. Remove the drain plug and gasket and drain the transaxle oil.
3. Install a new gasket and the drain plug.

Torque:

39 N*m { 400 kgf*cm , 29 ft.*lbf }

13. REMOVE EGR INLET EXHAUST MANIFOLD PLATE

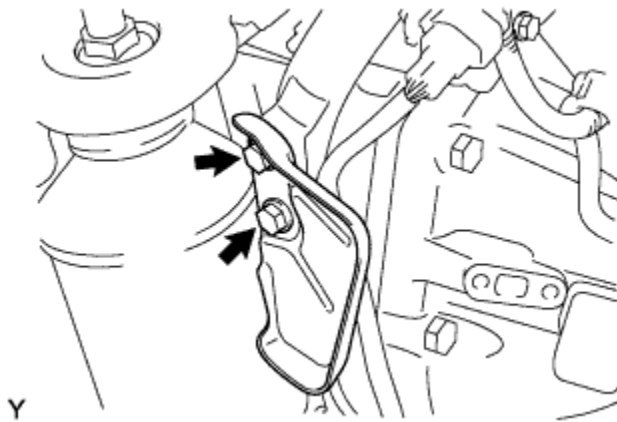

1. Remove the 2 bolts and the EGR inlet exhaust manifold plate.

14. REMOVE EXHAUST PIPE ASSEMBLY FRONT

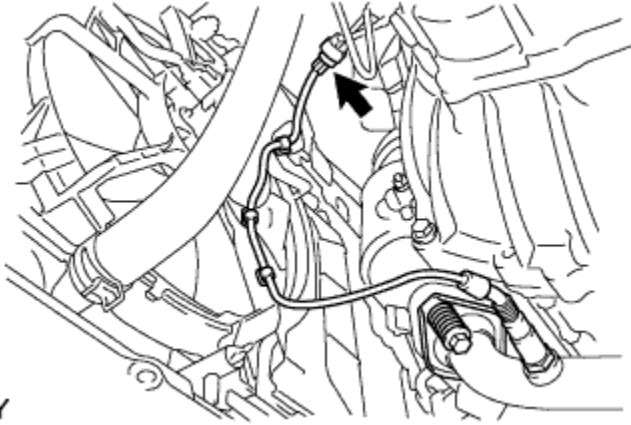

1. Disconnect the oxygen sensor connector, and disengage the 3 wire harness clamps.

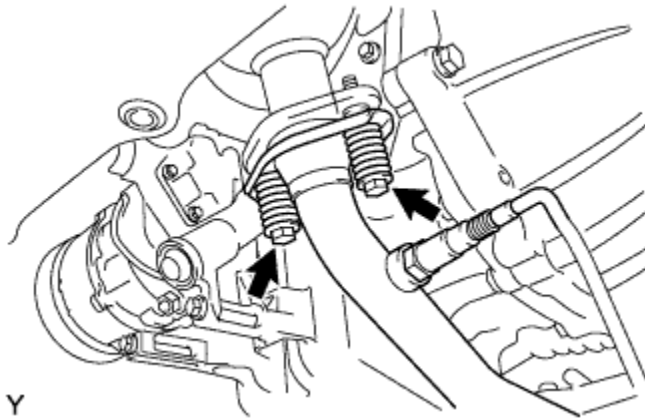

2. Remove the 2 bolts and compression springs, and separate the exhaust pipe front from the exhaust manifold.

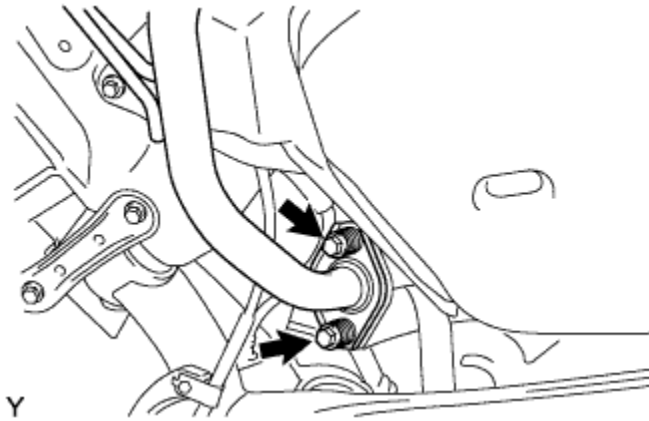

3. Remove the 2 bolts and compression springs, and separate the exhaust pipe front from the exhaust pipe tail.

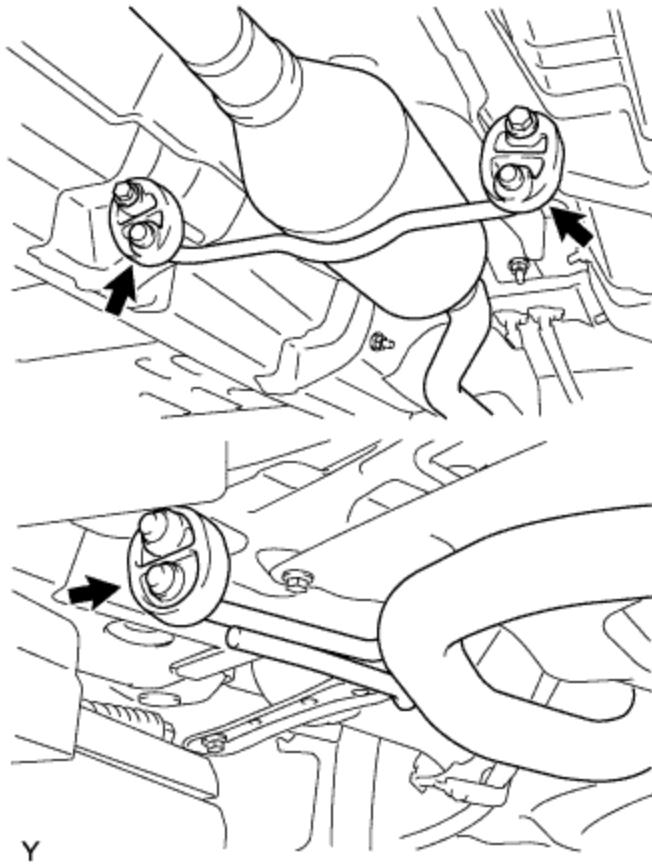

4. Remove the 3 supports, and remove the exhaust pipe front.

15. REMOVE FRONT WHEELS

16. REMOVE FRONT WIPER ARM HEAD CAP

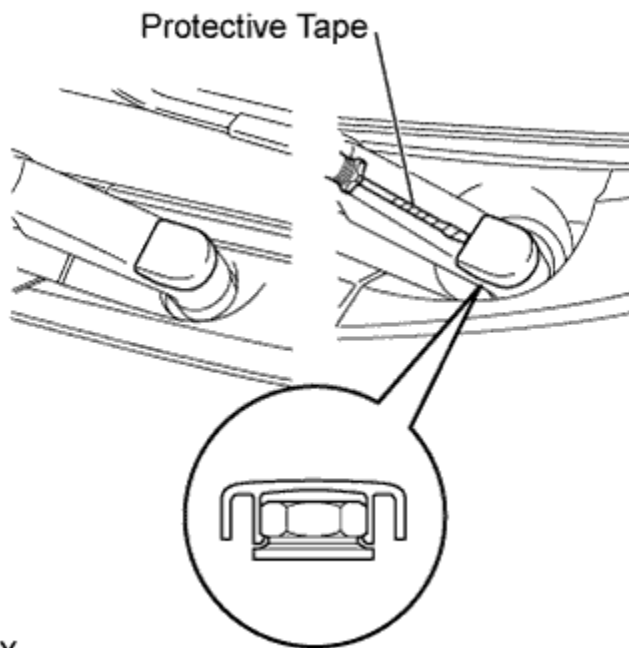

Y

1. Using a screwdriver with its tip wrapped in protective tape, disengage the claw and remove the 2 front wiper arm head caps.

17. REMOVE FRONT WIPER ARM AND BLADE ASSEMBLY LH

1. Operate the wiper, then stop the windshield wiper motor in the automatic stop position.

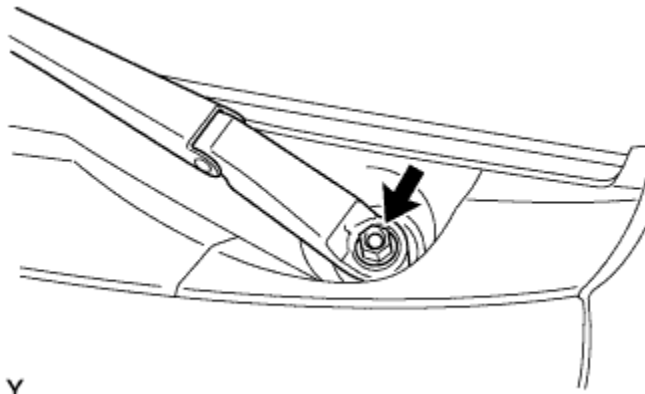

2. Remove the nut and front wiper arm.

18. REMOVE FRONT WIPER ARM AND BLADE ASSEMBLY RH

HINT:

Use the same procedure as for the LH side.

19. REMOVE HOOD TO COWL TOP SEAL

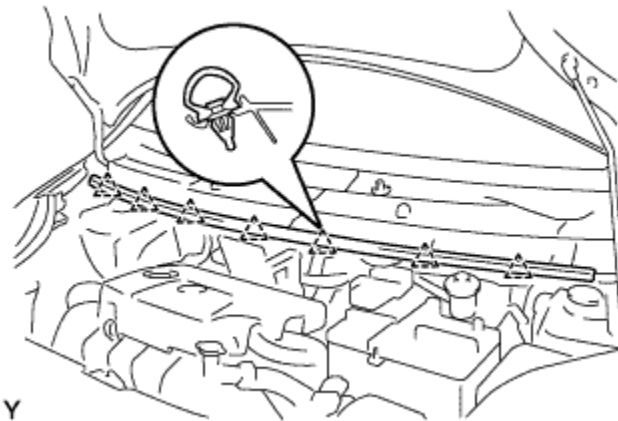

1. Disengage the 7 clips and remove the hood to cowl top seal.

20. REMOVE COWL TOP VENTILATOR LOUVER SUB-ASSEMBLY (for LHD)

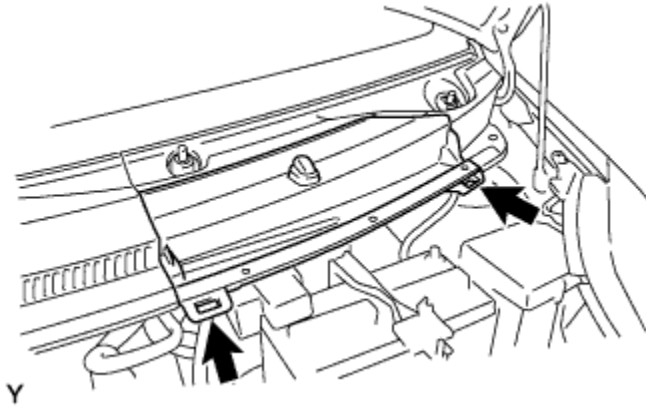

1. Disengage the 2 hooks and remove cowl top ventilator louver center No. 1.

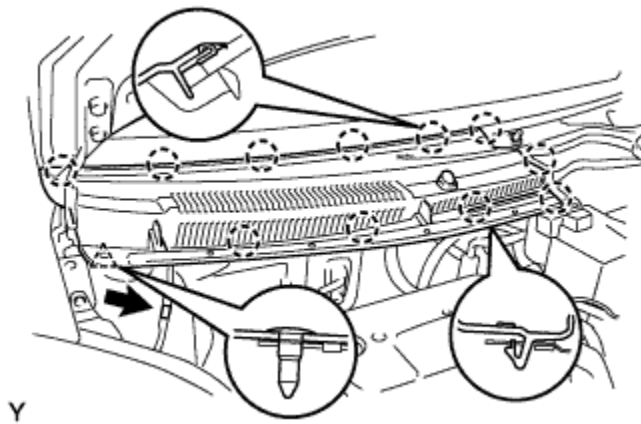

2. Disconnect the washer hose.
3. Disengage the 11 claws and clip.

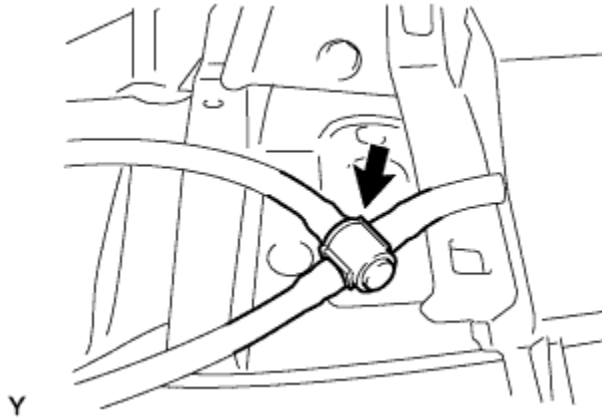

4. Disconnect the washer hose and remove the cowl top ventilator louver sub-assembly.

21. REMOVE COWL TOP VENTILATOR LOUVER LH (for LHD)

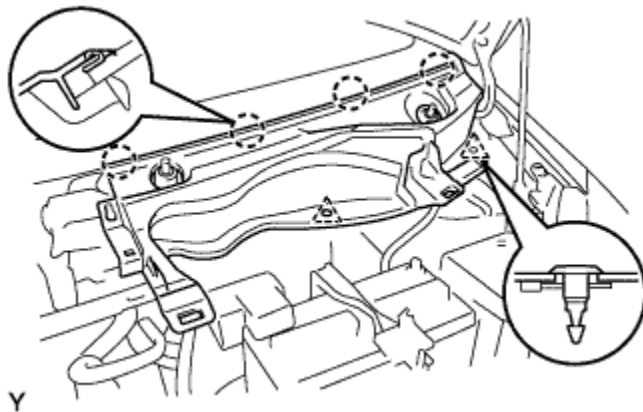

1. Remove the 2 clips.
2. Disengage the 4 claws and remove the cowl top ventilator louver LH.

22. REMOVE COWL TOP VENTILATOR LOUVER SUB-ASSEMBLY (for RHD)

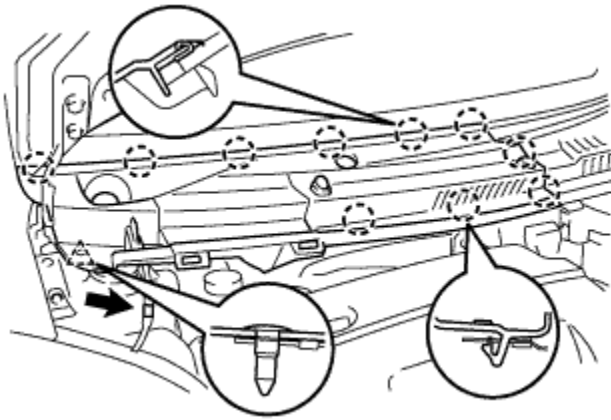

Y

1. Disconnect the washer hose.
2. Disengage the 10 claws and clip and remove the cowl top ventilator louver sub-assembly.

| |
|--|
| 23. REMOVE COWL TOP VENTILATOR LOUVER LH (for RHD) |
|--|

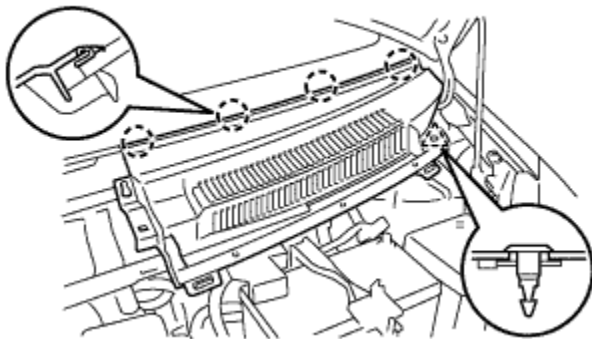

Y

1. Remove the clip.
2. Disengage the 4 claws and remove the cowl top ventilator louver LH.

24. REMOVE FRONT WIPER MOTOR AND LINK ASSEMBLY

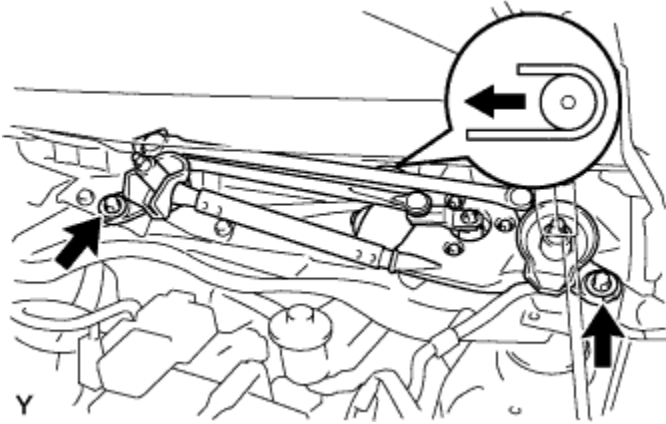

1. Remove the 2 bolts.
2. Slide the wiper link. Disengage the meshing of the rubber pin, then disconnect the connector and remove the front wiper motor and link.

25. REMOVE COWL TO REGISTER DUCT SUB-ASSEMBLY NO. 2

for LHD:

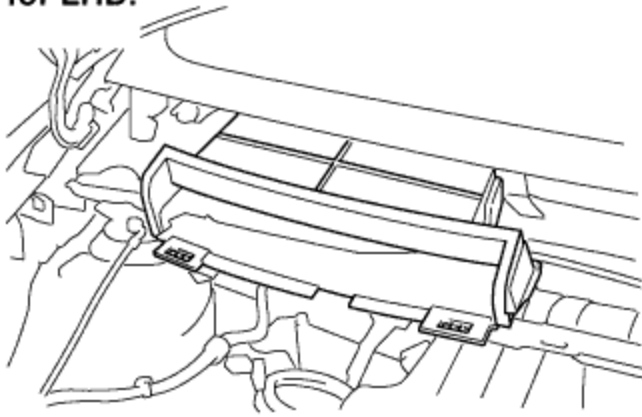

for RHD:

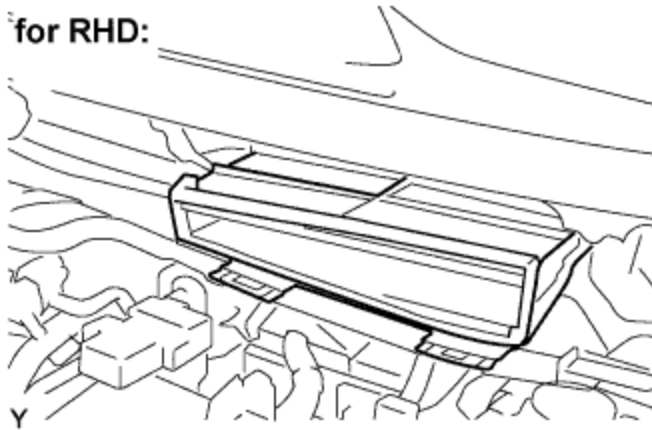

1. Disengage the claws, and remove cowl to resistor duct No. 2.

26. REMOVE COWL TOP PANEL OUTER

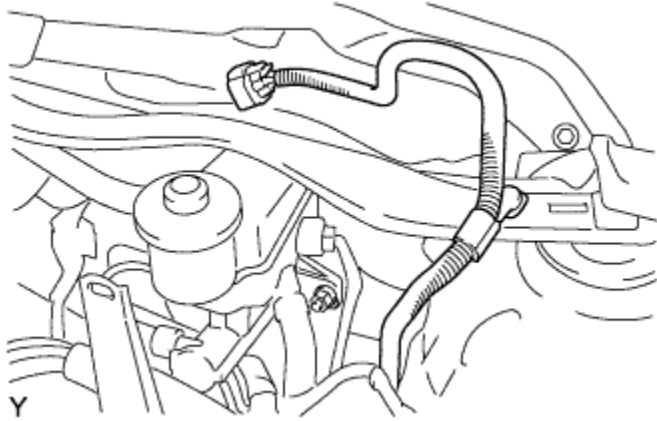

1. Disengage the clamp, and separate the wiper motor connector.

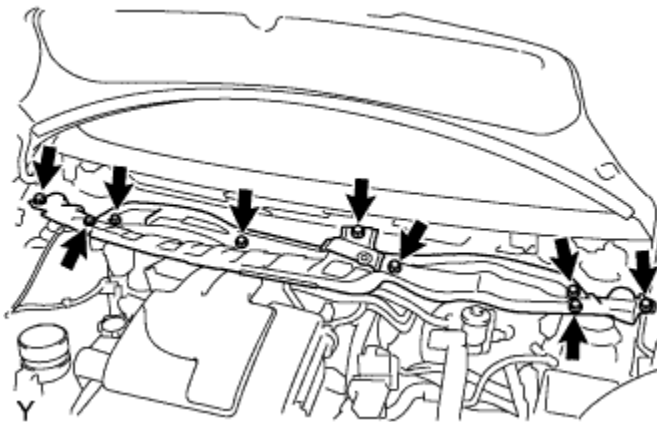

2. Remove the 9 bolts and the cowl top panel outer.

27. REMOVE AIR CLEANER CAP SUB-ASSEMBLY

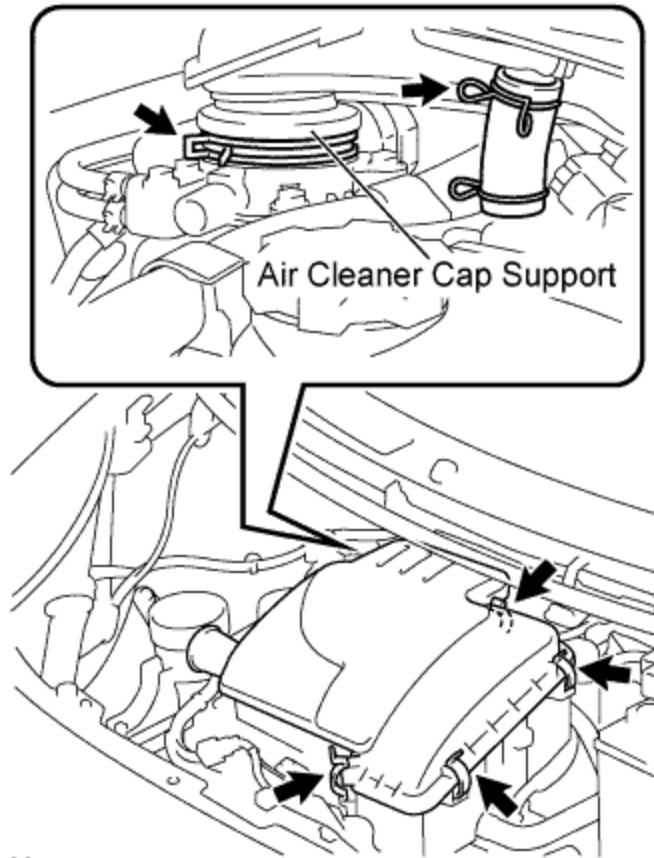

Y

1. Remove the 4 clamps.
2. Remove the 2 clamps and remove the air cleaner cap.

28. REMOVE AIR CLEANER FILTER ELEMENT SUB-ASSEMBLY

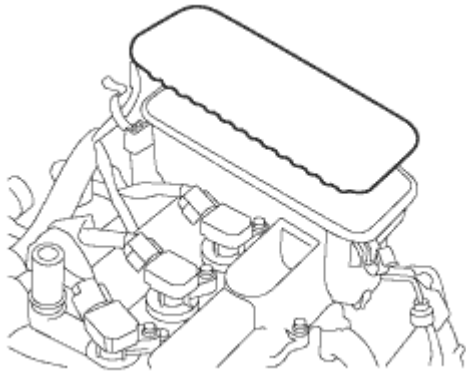

1. Remove the air cleaner filter element from the cylinder head cover.

29. REMOVE VENTILATION HOSE NO. 2

30. REMOVE FAN AND GENERATOR V BELT

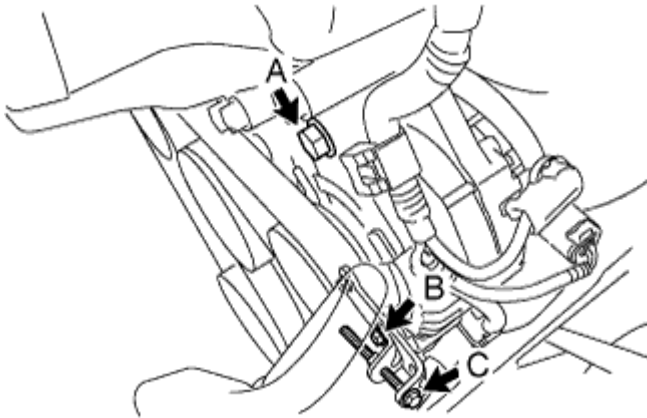

1. Loosen bolt A.
2. Loosen bolt B.
3. Loosen bolt C.
4. Release the drive belt tension and remove the fan and generator V belt.

31. REMOVE GENERATOR ASSEMBLY

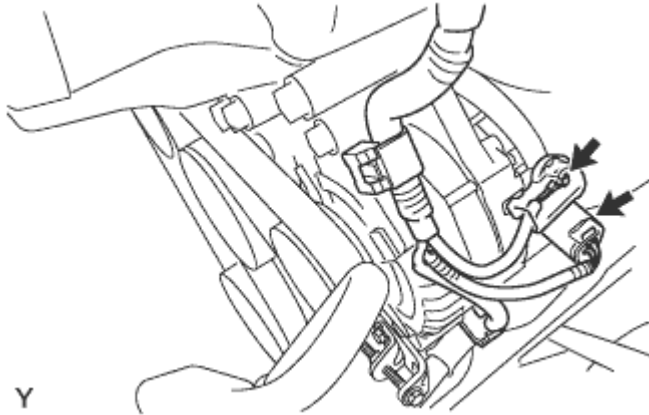

1. Disconnect the connector.
2. Remove the terminal cap.
3. Remove the nut and separate terminal B.
4. Disengage the 2 clamps and separate the wire harness.

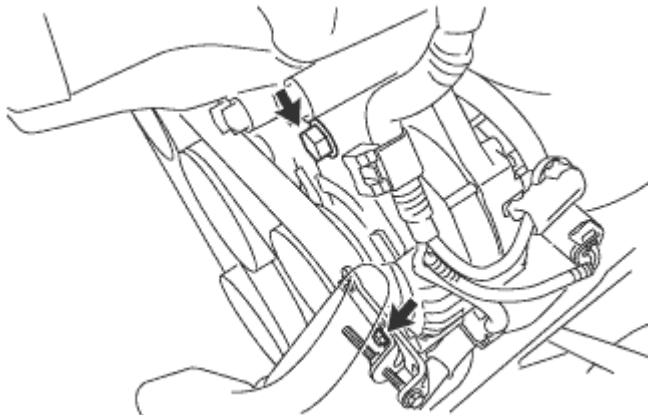

5. Remove the 2 bolts and the generator.

32. REMOVE FAN BELT ADJUSTING BAR

1. Remove the bolt and the fan belt adjusting bar.

33. DISCONNECT FUEL VAPOR FEED HOSE NO. 1



1. Disconnect the fuel vapor feed hose from the vacuum switching valve.

34. DISCONNECT WIRE HARNESS (for Multi-Mode Manual Transaxle)

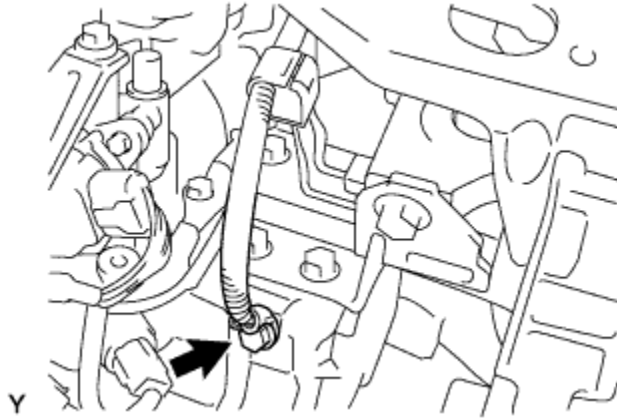

1. Remove the bolt, then disconnect the wire harness.

35. DISCONNECT CONNECTOR (for Multi-Mode Manual Transaxle)

1. Disconnect the shift stroke sensor connector.
2. Disconnect the select stroke sensor connector.
3. Disconnect the transmission revolution sensor connector.
4. Disconnect the back-up light switch connector.
5. Disconnect the neutral start switch connector.
6. Disconnect the shift and select motor connectors.

36. SEPARATE CLUTCH RELEASE CYLINDER ASSEMBLY (for Manual Transaxle)

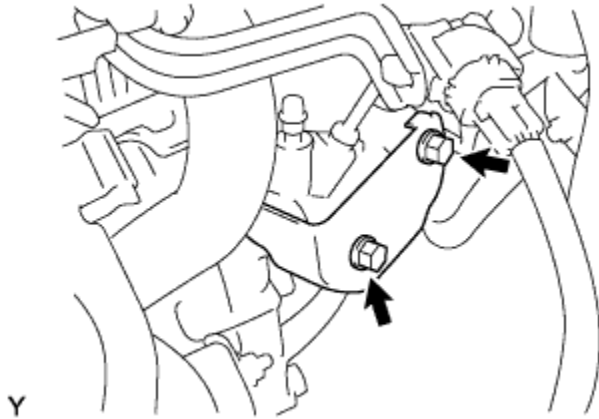

1. Remove the 2 bolts and the release cylinder heat insulator.

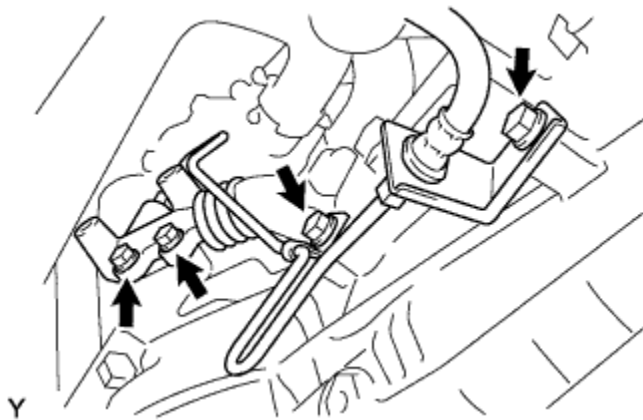

2. Remove the 4 bolts, then separate the clutch release cylinder.

HINT:

Using a piece of rope or the equivalent, hang the clutch release cylinder so as not to apply excessive load to the clutch pipe.

37. SEPARATE TRANSMISSION CONTROL CABLE ASSEMBLY (for Manual Transaxle)

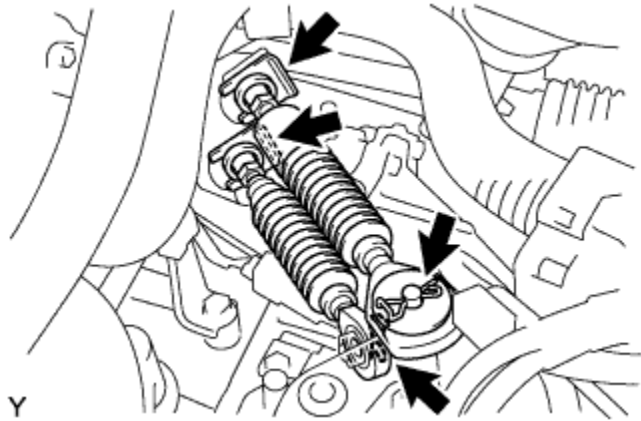

1. Remove the 2 clips and the 2 washers, and disconnect the 2 cables from the transaxle.
2. Remove the 2 clips and disconnect the 2 cables from the control cable bracket.

38. DISCONNECT BOOSTER VACUUM TUBE

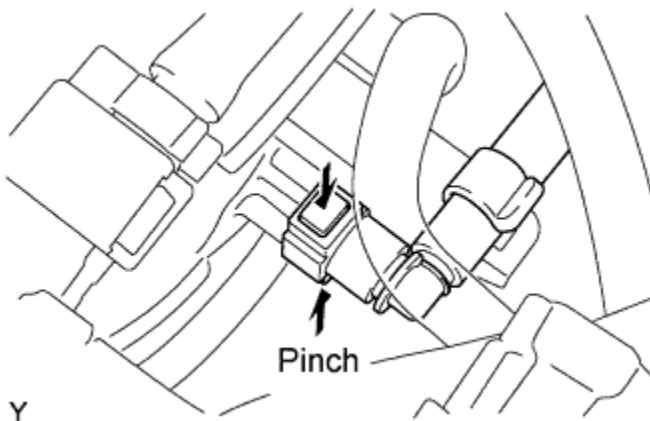

1. Pinch the retainer as illustrated, then pull the vacuum hose connector out of the pipe.

39. DISCONNECT RADIATOR HOSE NO. 1

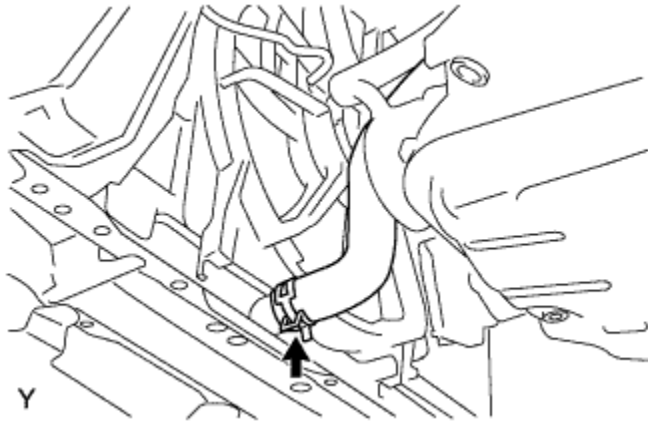

40. DISCONNECT RADIATOR HOSE NO. 2

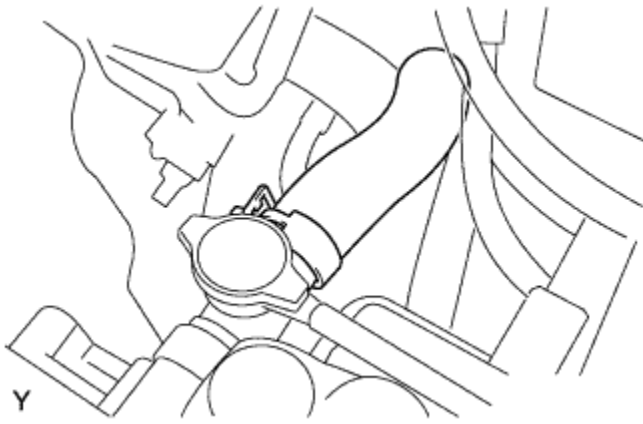

41. DISCONNECT HEATER WATER OUTLET HOSE A(FROM HEATER UNIT)

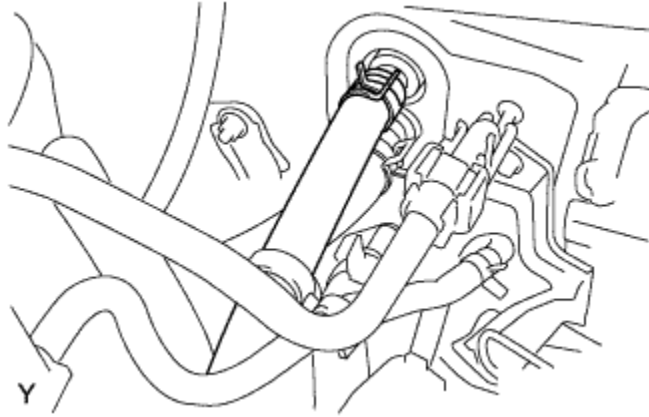

42. DISCONNECT HEATER WATER INLET HOSE A

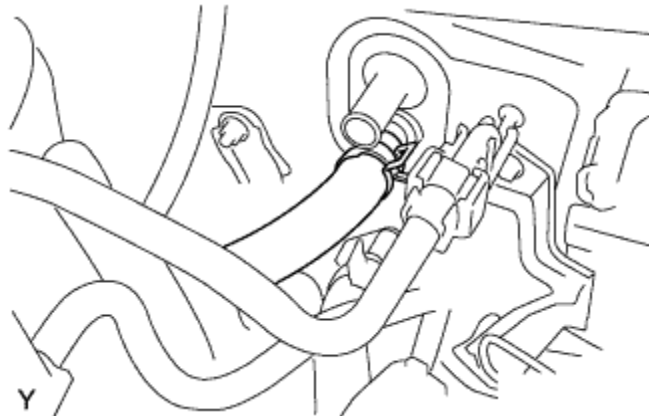

43. SEPARATE FUEL TUBE SUB-ASSEMBLY

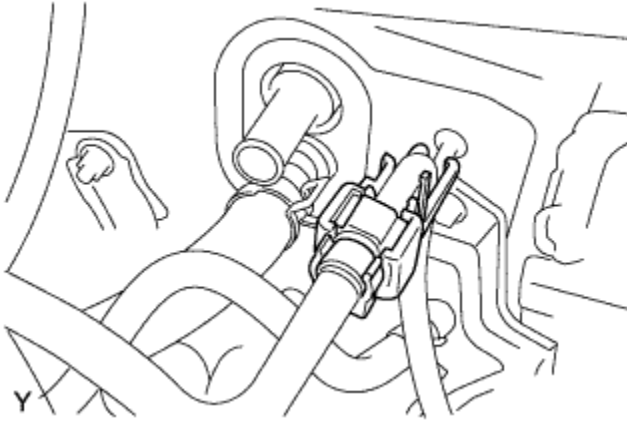

1. Remove fuel pipe clamp No. 1.

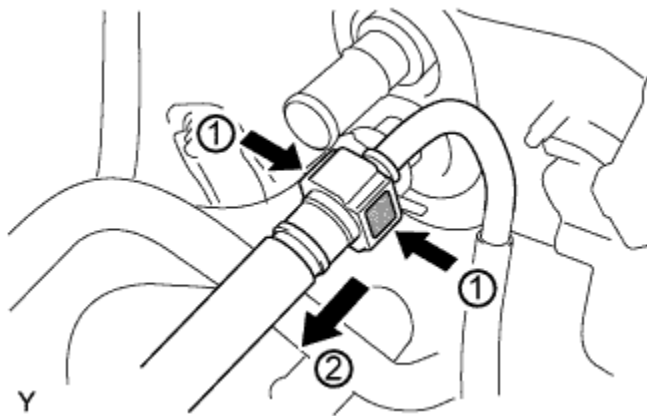

2. Pinch the retainer as illustrated, then pull the fuel tube connector out of the pipe.

NOTICE:

- Remove any dirt and foreign matter from the fuel tube connector before performing this work.
- Do not allow any scratches or foreign matter on the parts when disconnecting, as the fuel tube connector has the O-rings that seals the pipe.
- Perform this work by hand. Do not use any tools.
- Do not forcibly bend, twist or turn the nylon tube.
- Protect the disconnected part by covering it with a vinyl bag after disconnecting the fuel tube.
- If the fuel tube connector and pipe are stuck, push and pull to release them.

44. REMOVE FRONT AXLE SHAFT LH NUT (for TMC Made)

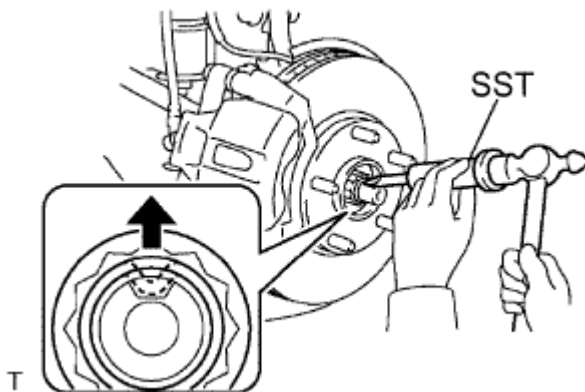

1. Using SST and a hammer, release the staked part of the axle hub nut.

SST
09930-00010
NOTICE:

- Insert SST into the groove with the flat surface facing up.
 - Do not damage the tip of SST using grinders.
 - Completely unstake the staked part before removing the axle hub nut.
 - Do not damage the threads of the drive shaft.
2. Using a 30 mm socket wrench, remove the axle hub nut.

45. REMOVE FRONT AXLE SHAFT LH NUT (for TMMF Made)

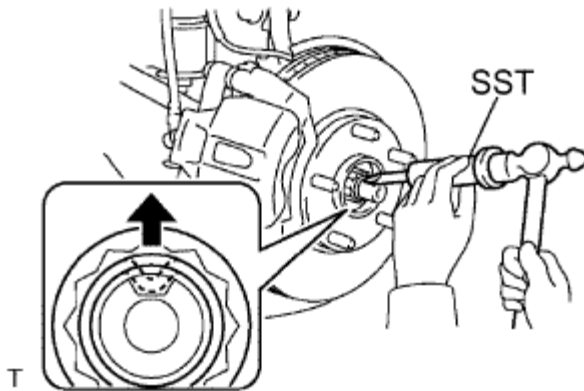

1. Using SST and a hammer, release the staked part of the axle hub nut.

SST
09930-00010
NOTICE:

- Insert SST into the groove with the flat surface facing up.
- Do not damage the tip of SST using grinders.
- Completely unstake the staked part before removing the axle hub nut.
- Do not damage the threads of the drive shaft.

2. Using a 30 mm socket wrench, remove the axle hub nut.

46. REMOVE FRONT AXLE SHAFT RH NUT (for TMC Made)

HINT:

The removal procedure for the RH side is the same as that for the LH side.

47. REMOVE FRONT AXLE HUB RH NUT (for TMMF Made)

HINT:

The removal procedure for the RH side is the same as that for the LH side.

48. SEPARATE SPEED SENSOR FRONT LH (for TMC Made)

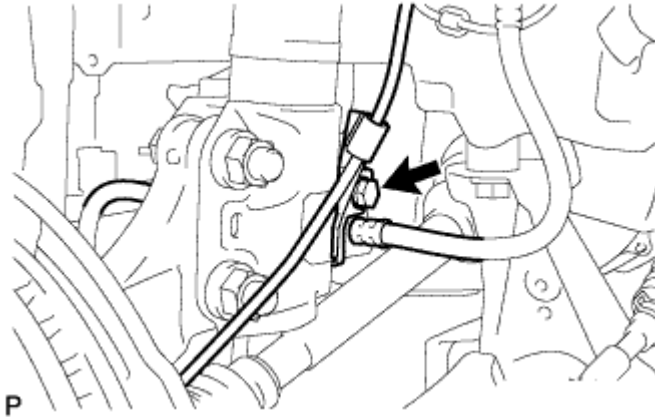

1. Remove the bolt and separate the speed sensor and flexible hose.

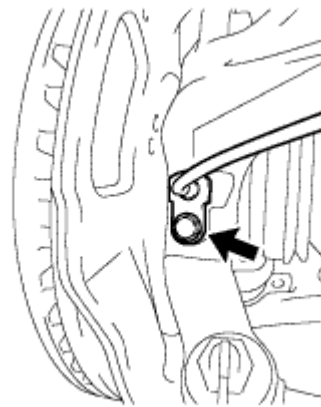

2. Remove the bolt and separate the speed sensor from the steering knuckle.

NOTICE:

- Keep the speed sensor tip and installation portion free of foreign matter.
- Remove the speed sensor without turning it from its original installation angle.

49. SEPARATE SPEED SENSOR FRONT LH (for TMMF Made)

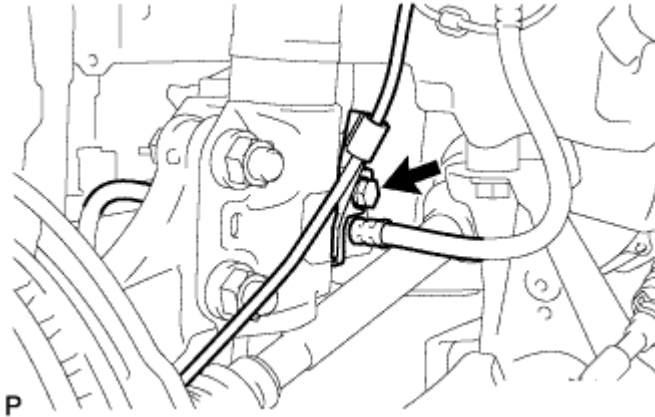

1. Remove the bolt and separate the speed sensor and flexible hose.

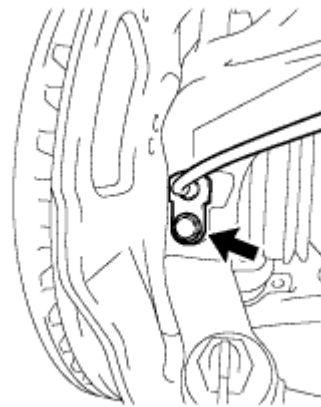

2. Remove the bolt and separate the speed sensor from the steering knuckle.

NOTICE:

- Keep the speed sensor tip and installation portion free of foreign matter.
- Remove the speed sensor without turning it from its original installation angle.

50. SEPARATE SPEED SENSOR FRONT RH (for TMC Made)

HINT:

The removal procedure for the RH side is the same as that for the LH side.

51. SEPARATE SPEED SENSOR FRONT RH (for TMMF Made)

HINT:

The removal procedure for the RH side is the same as that for the LH side.

52. SEPARATE TIE ROD END SUB-ASSEMBLY LH (for TMC Made)

1. Remove the cotter pin and castle nut.

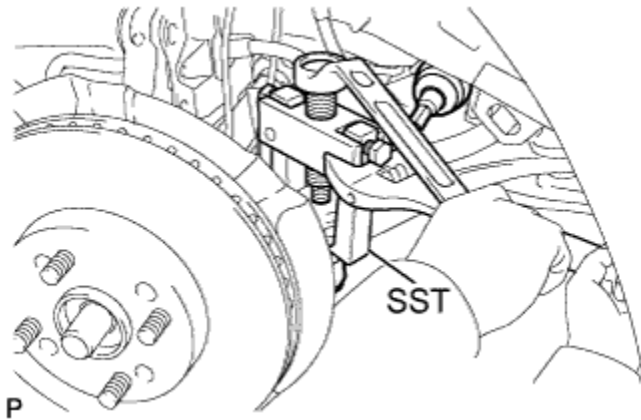

2. Using SST, separate the tie rod end from the steering knuckle.

SST

09628-62011

NOTICE:

Do not damage the tie rod end dust cover.

53. SEPARATE TIE ROD END SUB-ASSEMBLY LH (for TMMF Made)

1. Remove the cotter pin and castle nut.

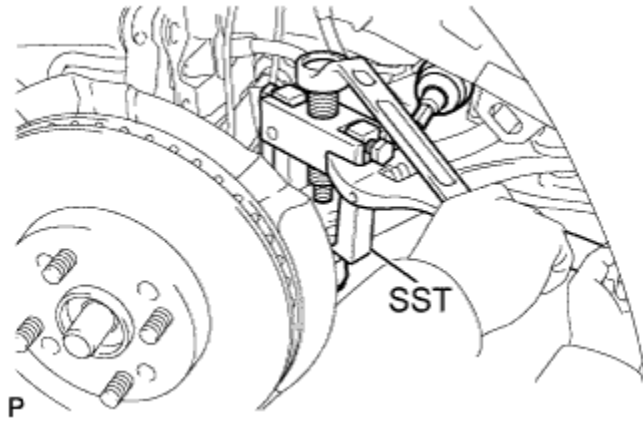

2. Using SST, separate the tie rod end from the steering knuckle.

SST

09628-62011

NOTICE:

Do not damage the tie rod end dust cover.

54. SEPARATE TIE ROD END SUB-ASSEMBLY RH (for TMC Made)

HINT:

The removal procedure for the RH side is the same as that for the LH side.

55. SEPARATE TIE ROD END SUB-ASSEMBLY RH (for TMMF Made)

HINT:

The removal procedure for the RH side is the same as that for the LH side.

56. SEPARATE FRONT STABILIZER LINK ASSEMBLY LH (for TMC Made)

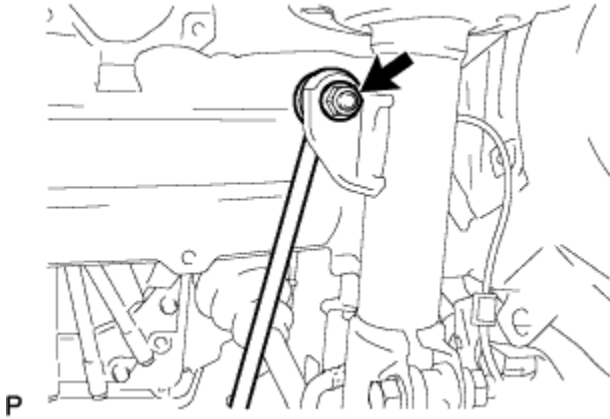

1. Remove the nut and separate the stabilizer link from the shock absorber.

HINT:

If the ball joint turns together with the nut, use a socket hexagon wrench 6 to hold the stud.

57. SEPARATE FRONT STABILIZER LINK ASSEMBLY RH (for TMMF Made)

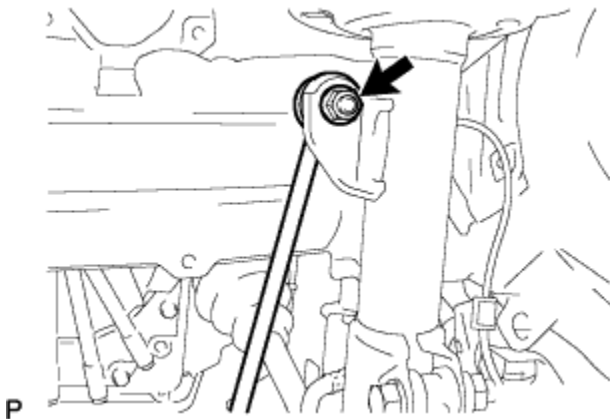

1. Remove the nut and separate the stabilizer link from the shock absorber.

HINT:

If the ball joint turns together with the nut, use a socket hexagon wrench 6 to hold the stud.

58. SEPARATE FRONT STABILIZER LINK ASSEMBLY RH (for TMC Made)

HINT:

The removal procedure for the RH side is the same as that for the LH side.

59. SEPARATE FRONT STABILIZER LINK ASSEMBLY RH (for TMMF Made)

HINT:

The removal procedure for the RH side is the same as that for the LH side.

60. SEPARATE FRONT SUSPENSION ARM SUB-ASSEMBLY LOWER NO. 1 LH
(for TMC Made)

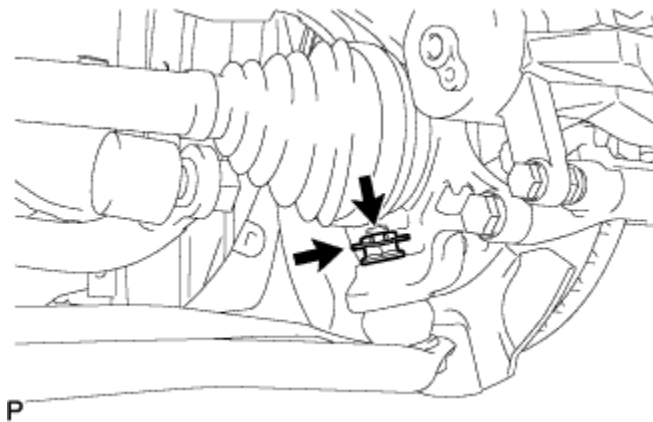

1. Remove the clip and castle nut.

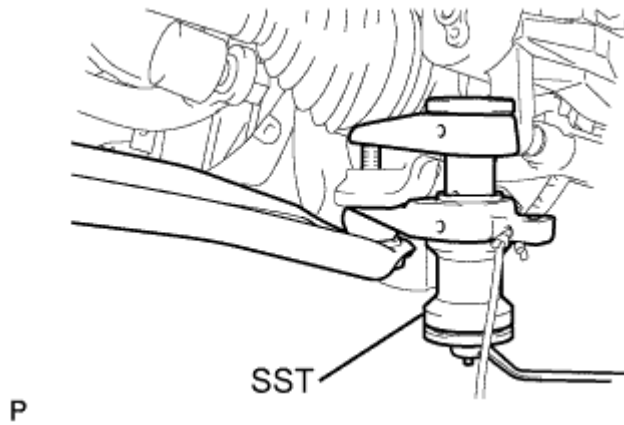

2. Using SST, separate the lower arm.

SST
09628-00011

NOTICE:

- Do not damage the lower ball joint dust cover.
- Suspend SST with a piece of string or the equivalent.

61. SEPARATE FRONT SUSPENSION ARM SUB-ASSEMBLY LOWER NO. 1 LH
(for TMMF Made)

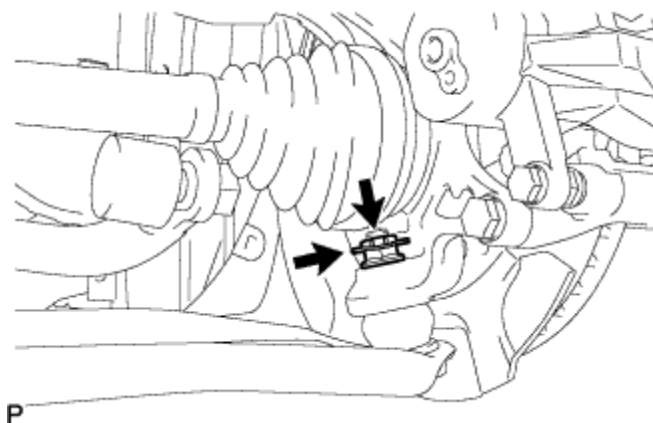

1. Remove the clip and castle nut.

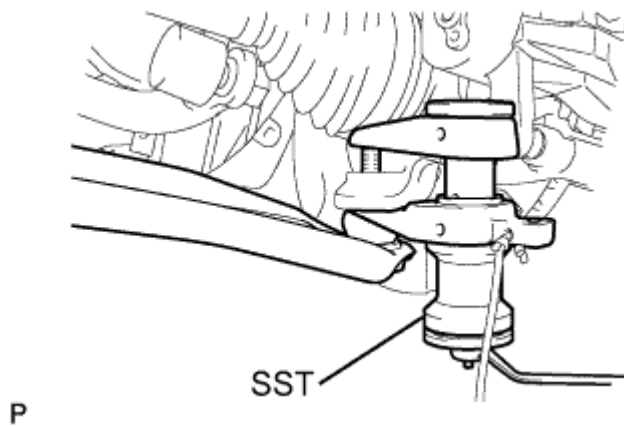

2. Using SST, separate the lower arm.

SST
09628-00011
NOTICE:

- Do not damage the lower ball joint dust cover.
- Suspend SST with a piece of string or the equivalent.

62. SEPARATE FRONT SUSPENSION ARM SUB-ASSEMBLY LOWER NO. 1 RH
(for TMC Made)

HINT:

The removal procedure for the RH side is the same as that for the LH side.

63. SEPARATE FRONT SUSPENSION ARM SUB-ASSEMBLY LOWER NO. 1 RH
(for TMMF Made)

HINT:

The removal procedure for the RH side is the same as that for the LH side.

64. SEPARATE FRONT AXLE ASSEMBLY LH (for TMC Made)

1. Using a plastic hammer, tap the end of the drive shaft and disengage the fitting between the drive shaft and front axle.

HINT:

If it is difficult to disengage the fitting, tap the end of the drive shaft with a brass bar and hammer.

2. Push the front axle out of the vehicle to remove the drive shaft from the front axle.

NOTICE:

- Do not push the front axle further out of the vehicle than is necessary.
- Do not damage the outboard joint boot.
- Do not damage the speed sensor rotor.
- Suspend the drive shaft with a piece of string or the equivalent.

65. SEPARATE FRONT AXLE ASSEMBLY LH (for TMMF Made)

1. Using a plastic hammer, tap the end of the drive shaft and disengage the fitting between the drive shaft and front axle.

HINT:

If it is difficult to disengage the fitting, tap the end of the drive shaft with a brass bar and hammer.

2. Push the front axle out of the vehicle to remove the drive shaft from the front axle.

NOTICE:

- Do not push the front axle further out of the vehicle than is necessary.
- Do not damage the outboard joint boot.
- Do not damage the speed sensor rotor.
- Suspend the drive shaft with a piece of string or the equivalent.

66. SEPARATE FRONT AXLE ASSEMBLY RH (for TMC Made)

HINT:

The removal procedure for the RH side is the same as that for the LH side.

67. SEPARATE FRONT AXLE ASSEMBLY RH (for TMMF Made)

HINT:

The removal procedure for the RH side is the same as that for the LH side.

68. REMOVE FRONT DRIVE SHAFT ASSEMBLY LH (for TMC Made)

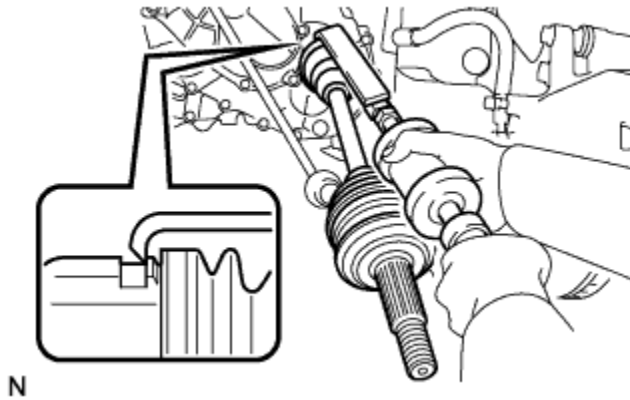

1. Using SST, remove the drive shaft.

SST

09520-01010

09520-24010 (09520-32040)

NOTICE:

- Do not damage the oil seal.
- Do not damage the inboard joint boot.
- Do not drop the drive shaft.

69. REMOVE FRONT DRIVE SHAFT ASSEMBLY LH (for TMMF Made)

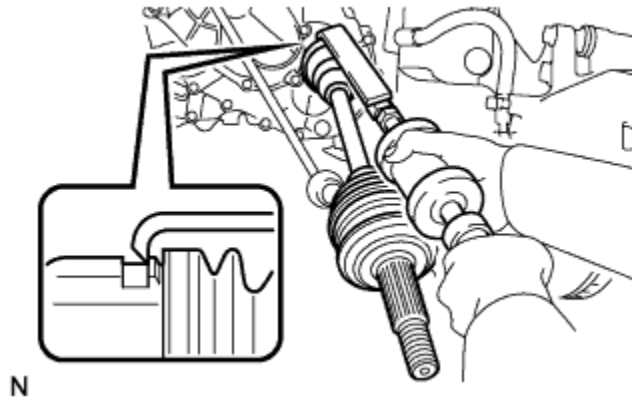

1. Using SST, remove the drive shaft.

SST
09520-01010
09520-24010 (09520-32040)
NOTICE:

- Do not damage the oil seal.
- Do not damage the inboard joint boot.
- Do not drop the drive shaft.

70. REMOVE FRONT DRIVE SHAFT ASSEMBLY RH (for TMC Made)

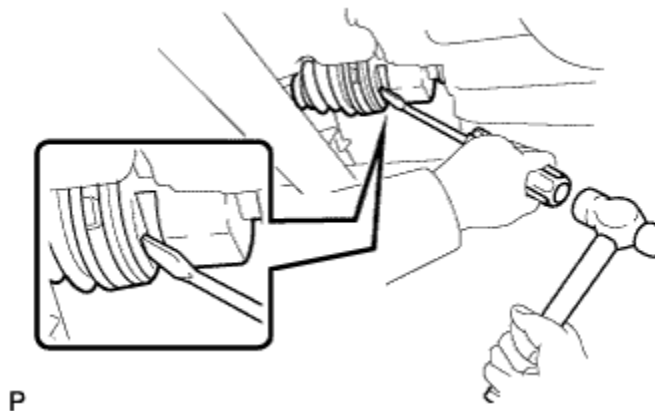

1. Using a screwdriver and hammer, remove the drive shaft.

NOTICE:

- Do not damage the oil seal.
- Do not damage the inboard joint boot.
- Do not drop the drive shaft.

71. REMOVE FRONT DRIVE SHAFT ASSEMBLY RH (for TMMF Made)

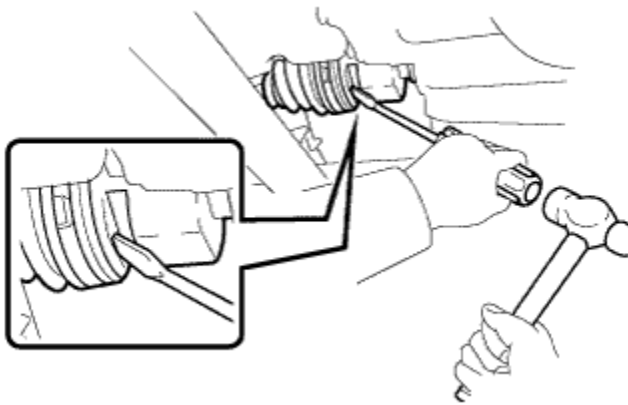

1. Using a screwdriver and hammer, remove the drive shaft.

NOTICE:

- Do not damage the oil seal.
- Do not damage the inboard joint boot.
- Do not drop the drive shaft.

72. REMOVE COLUMN HOLE COVER SILENCER SHEET

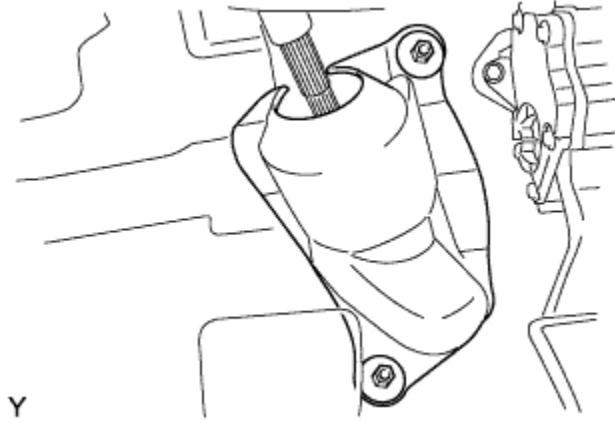

1. Remove the 2 clips and the column hole cover silencer sheet.

73. SEPARATE STEERING INTERMEDIATE SHAFT ASSEMBLY NO. 2

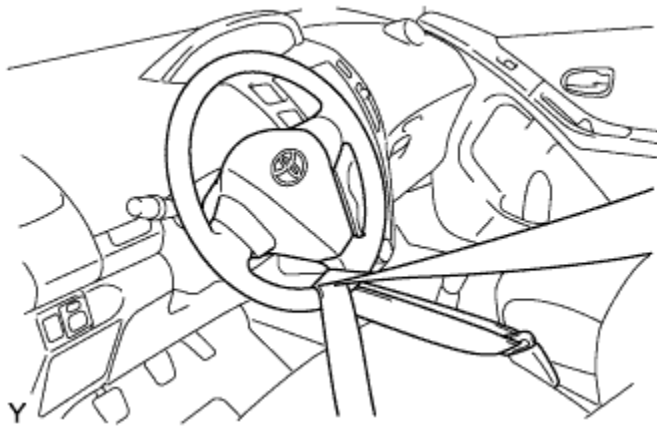

1. Hold the steering wheel with the seatbelt to avoid steering wheel rotation and damage to the spiral cable.

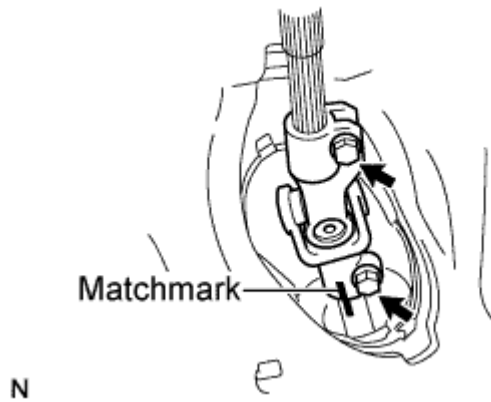

2. Put a matchmark on the sliding yoke and the intermediate shaft.
3. Loosen the 2 bolts to separate the sliding yoke.

74. REMOVE STEERING COLUMN HOLE COVER SUB-ASSEMBLY NO. 1

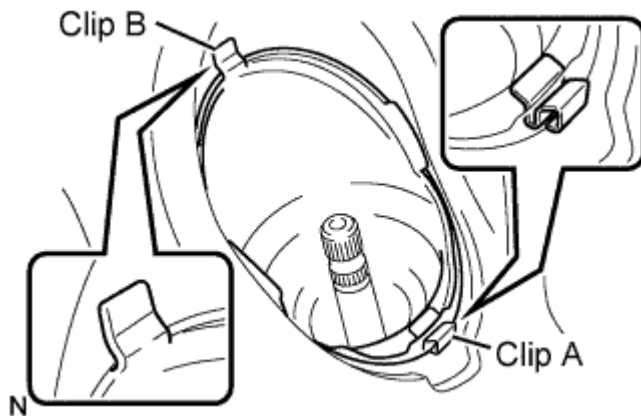

1. Remove clip A and separate the steering column hole cover from the body.

NOTICE:
Do not damage clip B.

75. SEPARATE ECM

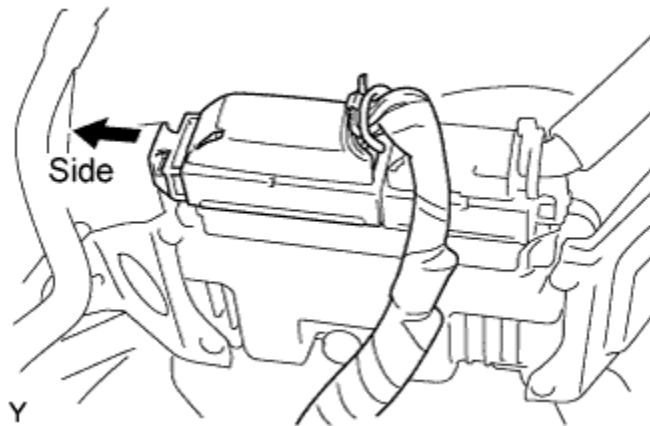

1. Move the pinch in the direction shown in the illustration and separate the connector.

76. SEPARATE ENGINE WIRE

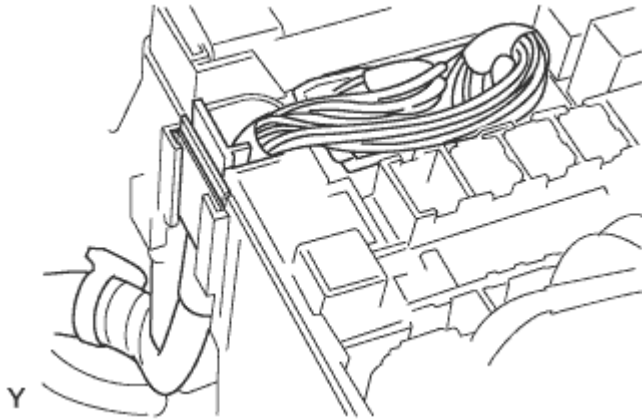

1. Remove the engine room relay block cover.
2. Disconnect the 2 connectors and disengage the wire harness clamp.

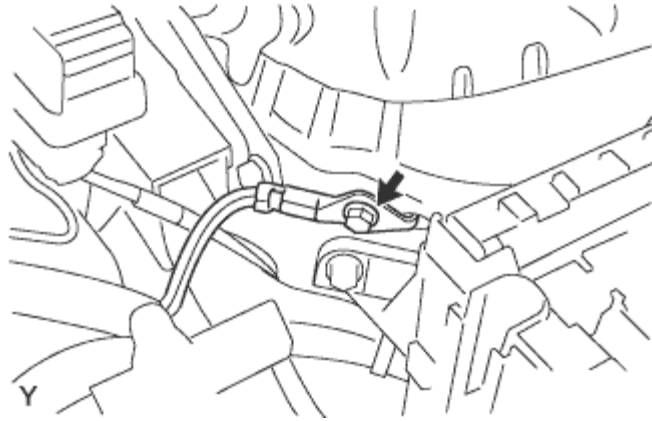

3. Remove the bolt and separate the earth wire.
4. Check that the engine wire harness is disconnected between the body and engine

77. SEPARATE WITH PULLEY COMPRESSOR ASSEMBLY (w/ Air Conditioning System)

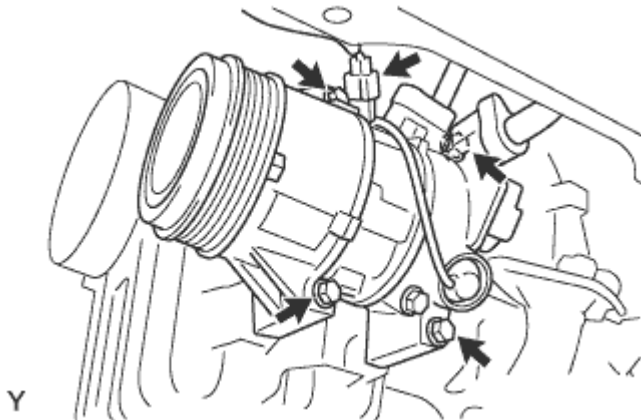

1. Disconnect the connector.
2. Remove the 4 bolts and separate the compressor.

HINT:

Secure the compressor and hoses off to the side instead of discharging the A/C system.

78. REMOVE ENGINE ASSEMBLY WITH TRANSAXLE

1. Set the engine lifter under the engine assembly with transaxle.

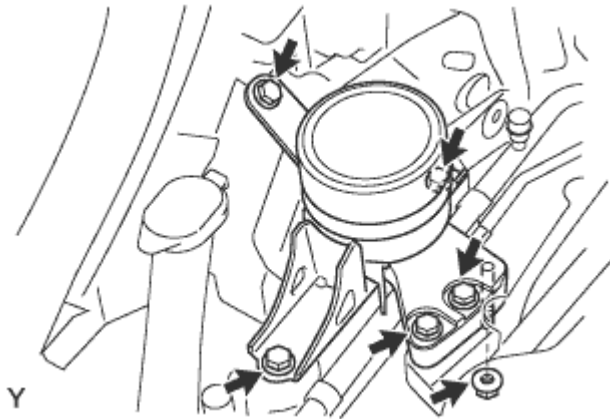

2. Remove the 5 bolts and the nut, then remove the engine mounting insulator RH.

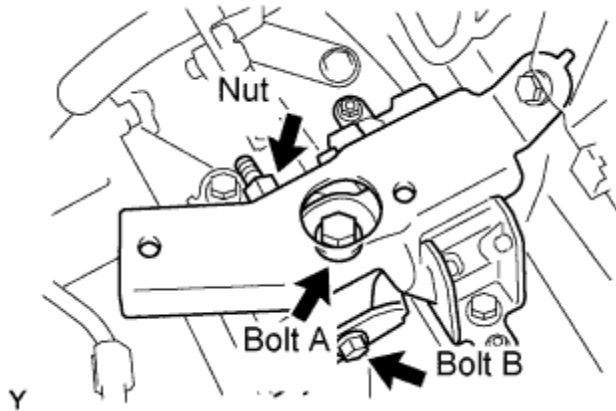

3. Remove bolt A from the engine mounting insulator LH.
4. Remove bolt B and the nut, and separate the engine mounting insulator LH.

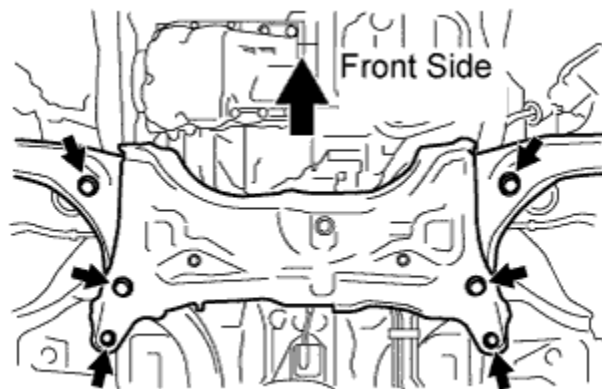

5. Remove the 6 bolts and the engine assembly with transaxle and front suspension member.

79. SUPPORT ENGINE ASSEMBLY WITH TRANSAXLE

1. Remove the bolt and separate the wire harness clamp.

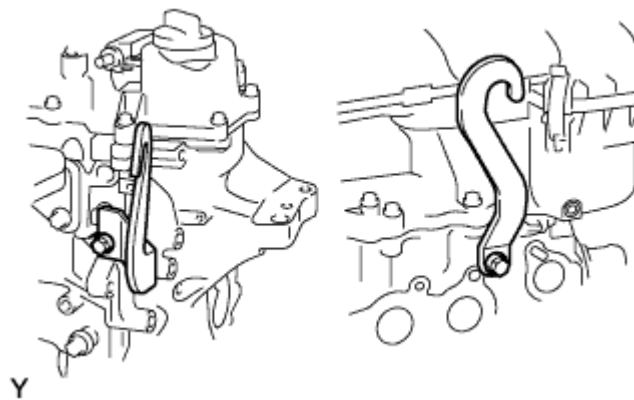

2. Install the engine hanger with the bolt.

Part No.:

No. 1 engine hanger:

12281 - 40030
No. 2 engine hanger:
12282 - 40010
Bolt:
91671 - 80820
Torque:
28 N*m { 286 kgf*cm , 21 ft.*lbf }

3. Attach the engine sling device to the engine hangers.

80. REMOVE FLYWHEEL HOUSING SIDE COVER (for 0.8 kW Type)

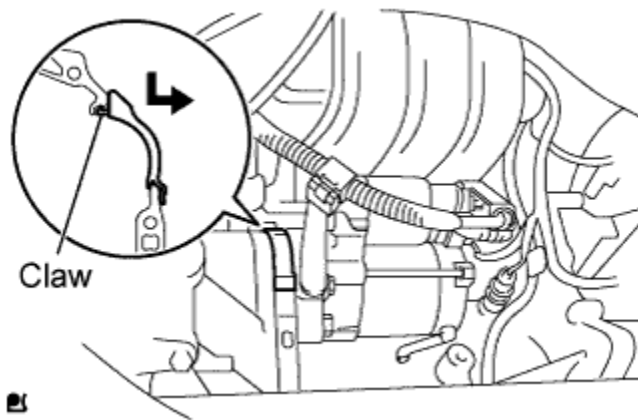

1. Disengage the claw while pushing it downward and remove the flywheel housing side cover.

81. REMOVE FLYWHEEL HOUSING SIDE COVER (for 0.9 kW Type)

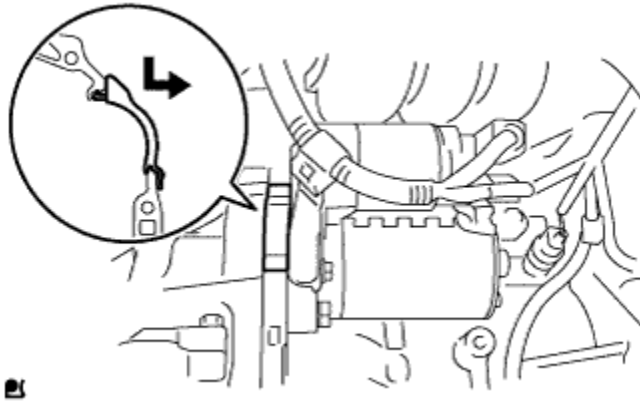

1. Disengage the claw while pushing it downward and remove the flywheel housing side cover.

82. REMOVE FLYWHEEL HOUSING SIDE COVER (for 1.0 kW Type)

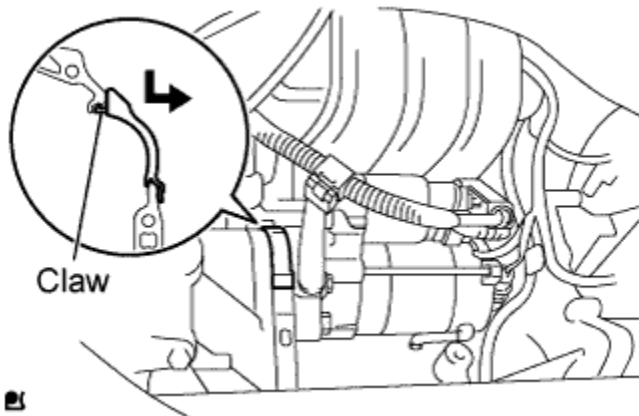

1. Disengage the claw while pushing it downward and remove the flywheel housing side cover.

83. REMOVE FLYWHEEL HOUSING SIDE COVER (for 1.3 kW Type)

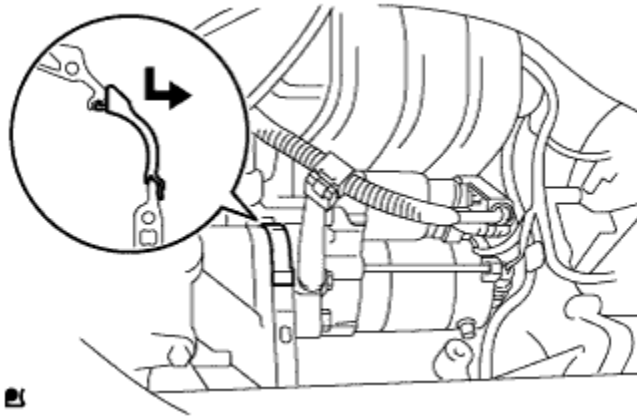

1. Disengage the claw while pushing it downward and remove the flywheel housing side cover.

84. REMOVE STARTER ASSEMBLY (for 0.8 kW Type)

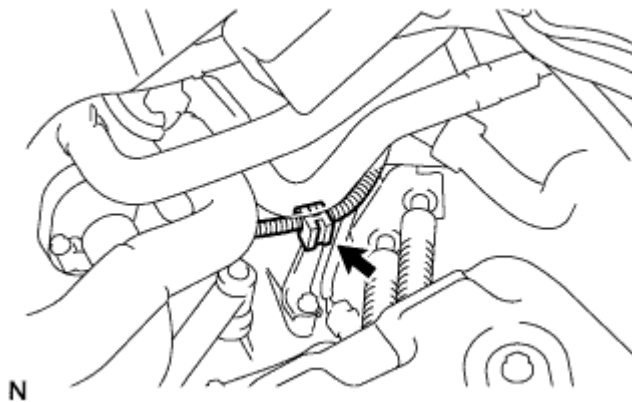

1. Separate the harness clamp.

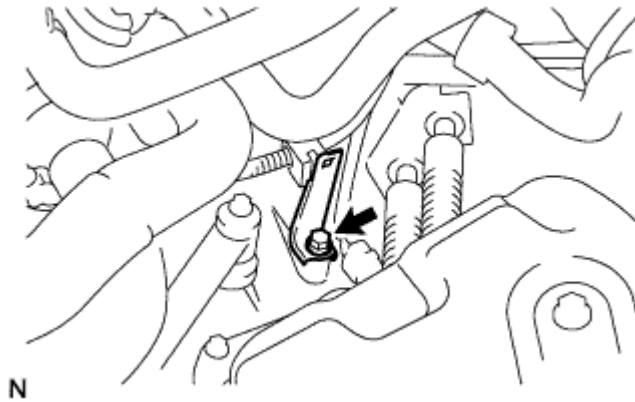

2. Remove the bolt and remove the wire harness bracket.

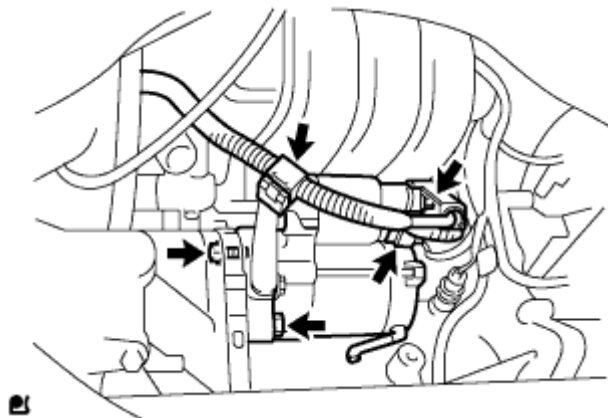

3. Remove the terminal cap.
4. Separate the harness clamp.
5. Remove the nut and disconnect terminal 30.
6. Disconnect the connector.
7. Remove the 2 bolts and remove the starter assembly.

| | |
|--|----------|
| 85. REMOVE STARTER ASSEMBLY (for 0.9 kW Type) | |
| Transaxle Type | See Page |

| | |
|-------|--|
| C551 | |
| C551A | |

86. REMOVE STARTER ASSEMBLY (for 1.0 kW Type)

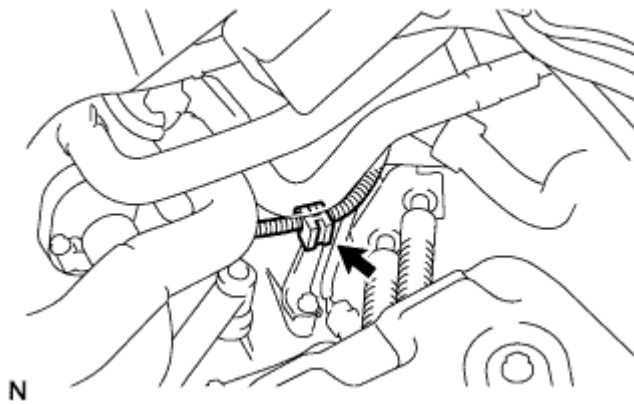

1. Separate the harness clamp.

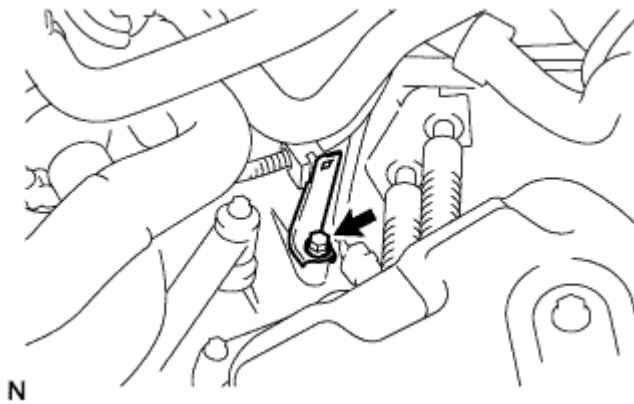

2. Remove the bolt and remove the wire harness bracket.

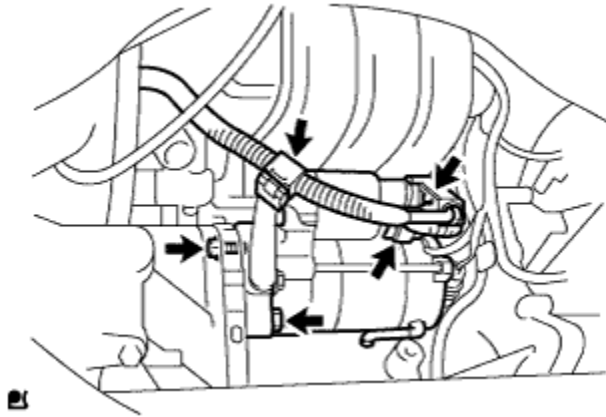

3. Remove the terminal cap.
4. Separate the harness clamp.
5. Remove the nut and disconnect terminal 30.
6. Disconnect the connector.
7. Remove the 2 bolts and remove the starter assembly.

| | |
|--|----------|
| 87. REMOVE STARTER ASSEMBLY (for 1.3 kW Type) | |
| Transaxle Type | See Page |
| C551 | |
| C551A | |

| |
|---|
| 88. SEPARATE ENGINE MOVING CONTROL ROD |
|---|



1. Remove the bolt and separate the engine moving control rod.

89. REMOVE MULTI-MODE MANUAL TRANSAXLE ASSEMBLY (for Multi-Mode Manual Transaxle)

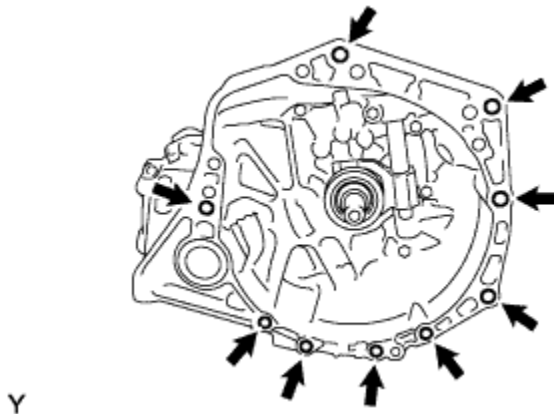

1. Remove the 9 bolts and the multi-mode manual transaxle.

90. REMOVE MANUAL TRANSAXLE ASSEMBLY (for Manual Transaxle)

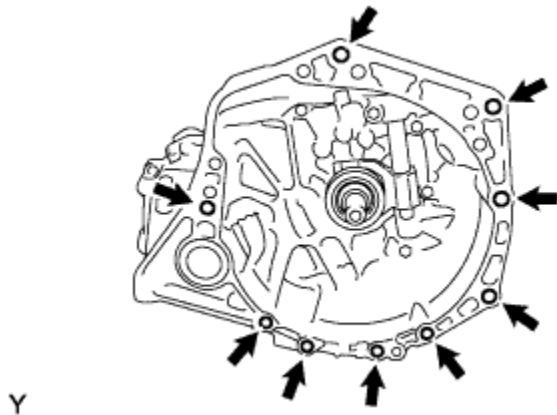

Y

1. Remove the 9 bolts and manual transaxle.

91. REMOVE CLUTCH COVER ASSEMBLY (for Multi-Mode Manual Transaxle)

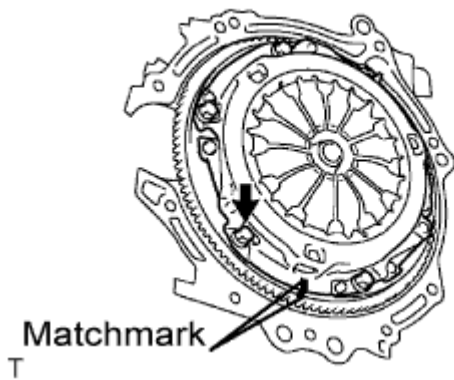

T

1. Place matchmarks on the flywheel and clutch cover.
2. Loosen each set bolt one turn at a time until the spring tension is released.
3. Remove the 6 bolts, and pull off the clutch cover with the clutch disc.

NOTICE:

- Do not drop the clutch disc.
- When replacing the clutch disc, be sure to replace it together with the clutch cover as a set.

92. REMOVE CLUTCH COVER ASSEMBLY (for Manual Transaxle)

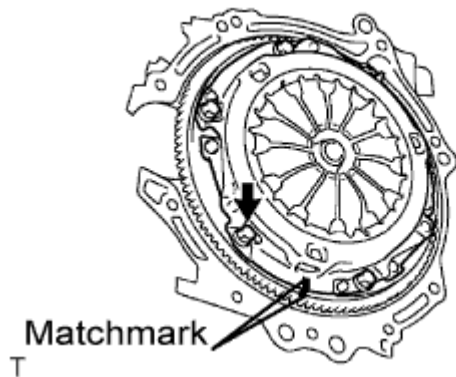

1. Align the matchmark on the clutch cover with the one on the flywheel.
2. Loosen each set bolt by one turn at a time until the spring tension is released.
3. Remove the set bolts and the clutch cover.

NOTICE:

Do not drop the clutch disc.

93. REMOVE CLUTCH DISC ASSEMBLY (for Manual Transaxle)

NOTICE:

Keep the lining part of the clutch disc and the surfaces of the pressure plate and flywheel free of oil and foreign matter.

94. REMOVE FLYWHEEL ASSEMBLY

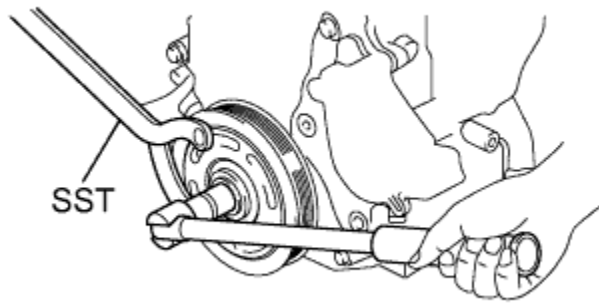

Y

1. Hold the crankshaft pulley with SST.

SST
09960-10010 (09962-01000, 09963-01000)

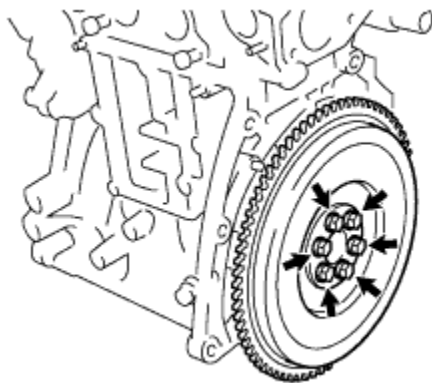

N

2. Remove the 6 bolts and the flywheel.

95. REMOVE IGNITION COIL NO. 1

1. Disconnect the 3 connectors.

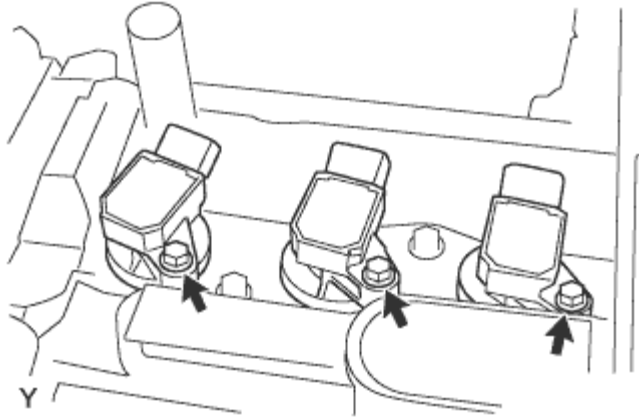

2. Remove the 3 bolts and 3 ignition coils.

96. REMOVE DUTY VACUUM SWITCHING VALVE

1. Disconnect the connector.

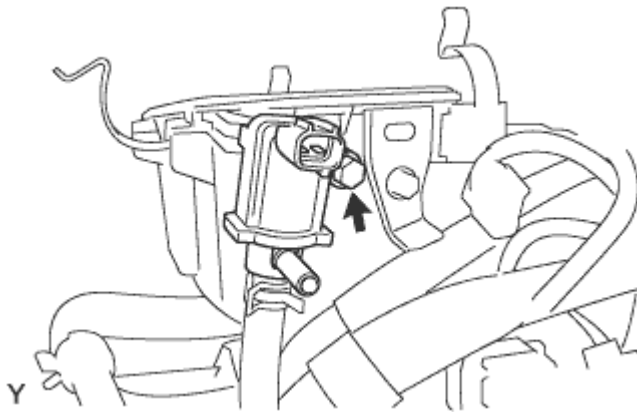

2. Remove the bolt and the duty vacuum switching valve.

97. REMOVE MANIFOLD STAY

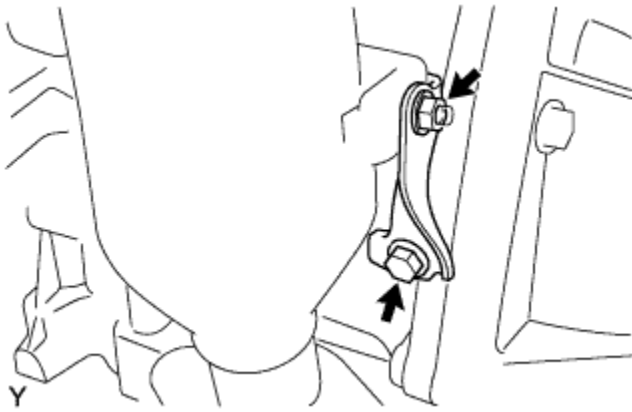

1. Remove the bolt and nut, and remove the manifold stay.

98. REMOVE EXHAUST MANIFOLD ASSEMBLY

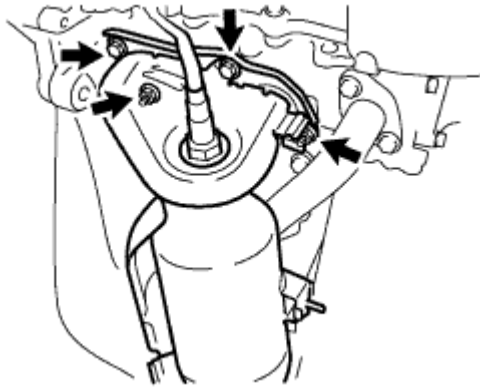

1. Remove the 2 bolts and 2 nuts.
2. Remove the exhaust manifold and gasket.

99. REMOVE THROTTLE WITH MOTOR BODY ASSEMBLY

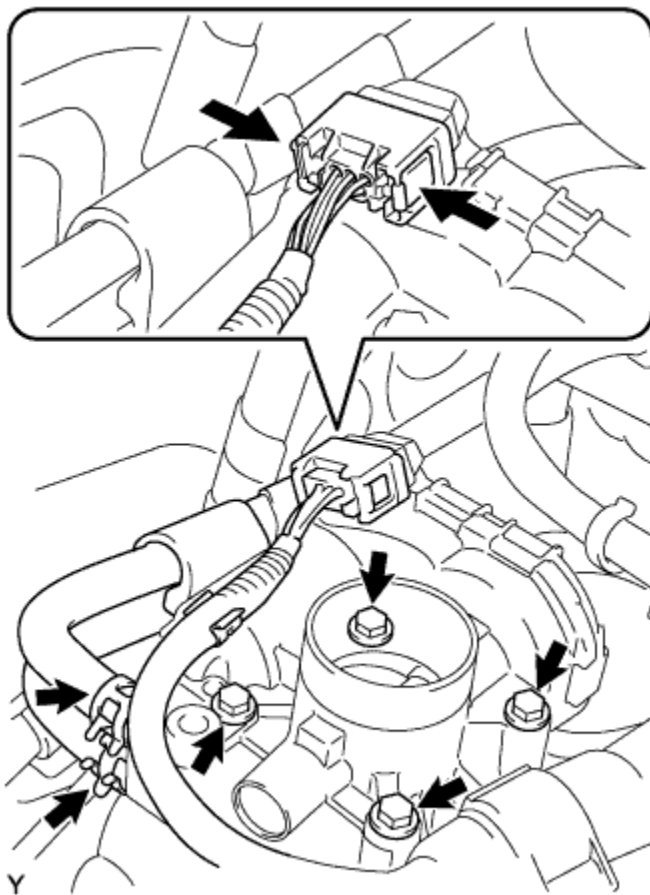

1. Pinch the connector as illustrated, then disconnect the connector.
2. Disconnect the 2 water by-pass hoses.
3. Remove the 4 bolts and the throttle body.

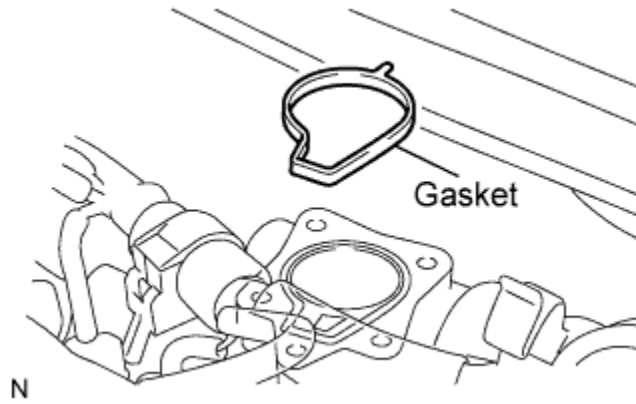

4. Remove the throttle body gasket.

100. REMOVE INTAKE MANIFOLD STAY



1. Remove the 2 bolts and the intake manifold stay.

101. REMOVE INTAKE MANIFOLD

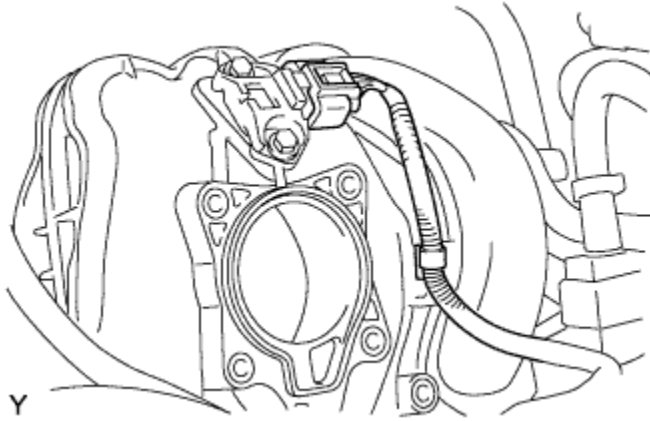

1. Disconnect the manifold absolute pressure sensor connector.
2. Separate the wire harness.

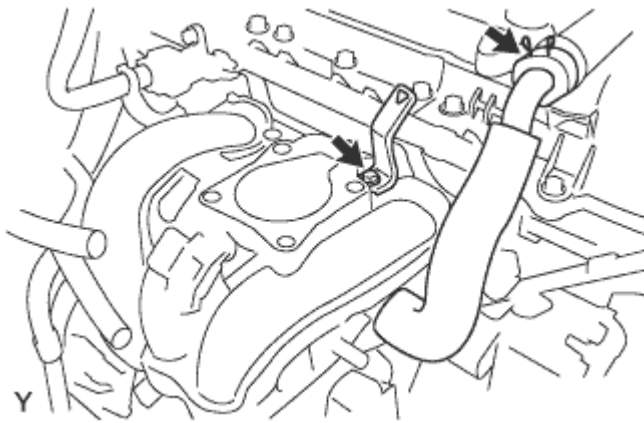

3. Remove the bolt and wire harness clamp.
4. Disconnect the ventilation hose.

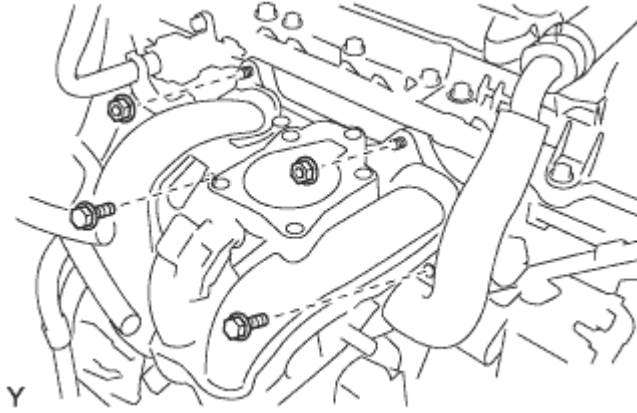

5. Remove the 2 bolts and 2 nuts.

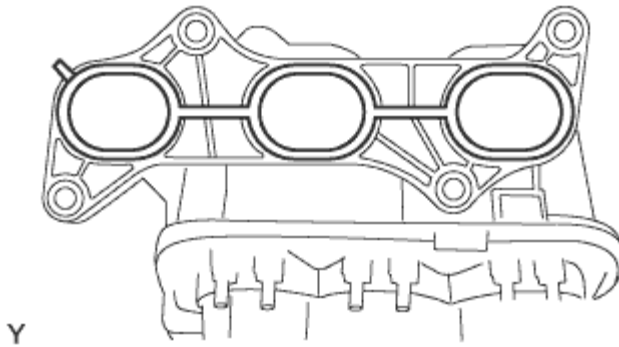

6. Remove the intake manifold and gasket.

| |
|--------------------------------|
| 102. REMOVE FUEL DELIVERY PIPE |
|--------------------------------|

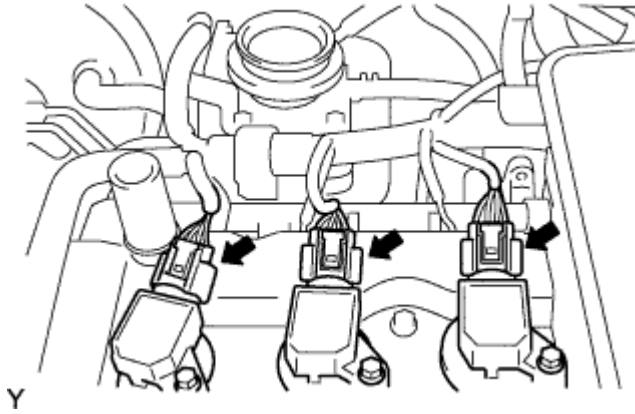

1. Disconnect the 3 ignition coil connectors.

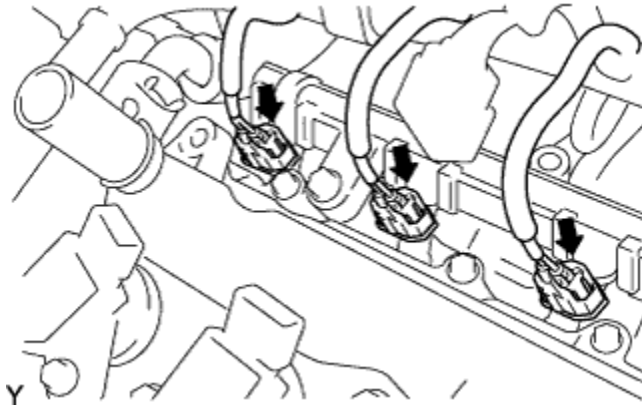

2. Disconnect the 3 injector connectors.

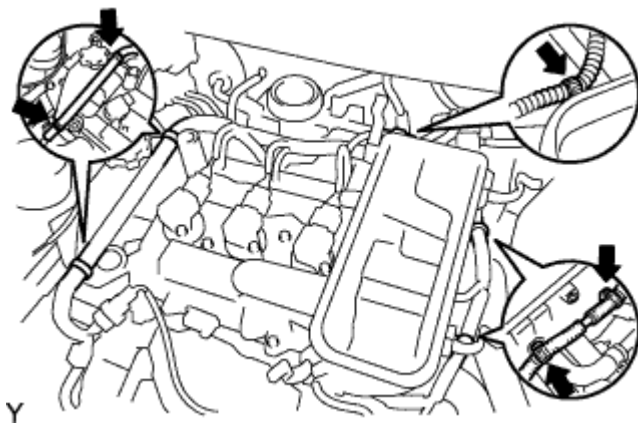

3. Disengage the 5 clamps, and separate the engine wire harness from the cylinder head cover.

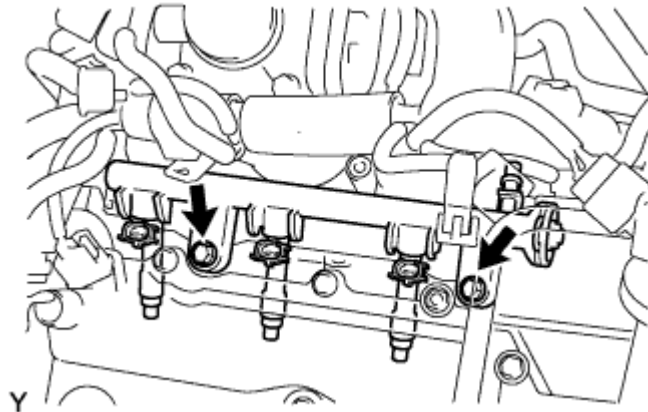

4. Remove the 2 bolts and delivery pipe together with the 3 injectors.

NOTICE:

Do not drop the injectors when removing the delivery pipe.

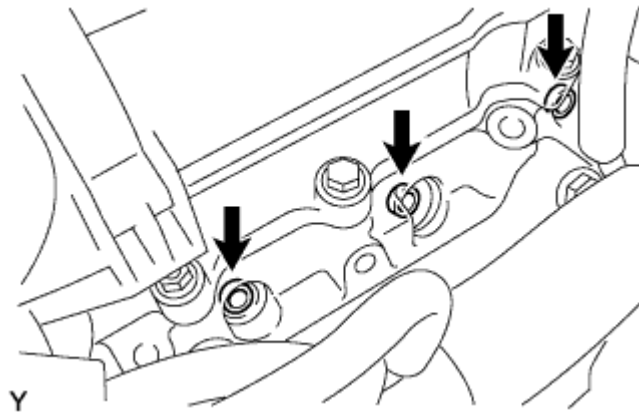

5. Remove the 3 injector vibration insulators from the cylinder head.

| |
|------------------------------------|
| 103. REMOVE FUEL INJECTOR ASSEMBLY |
|------------------------------------|

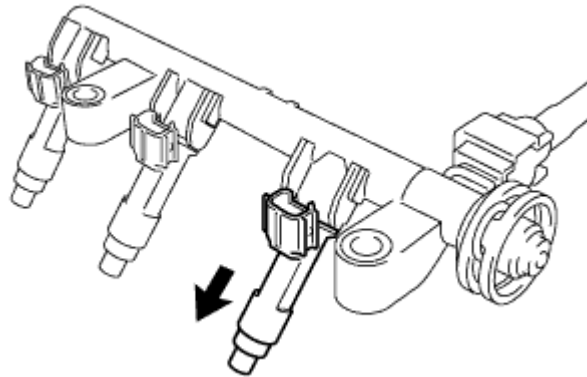

Y

1. Pull the 3 injectors out of the fuel delivery pipe.

104. REMOVE RADIO SETTING CONDENSER

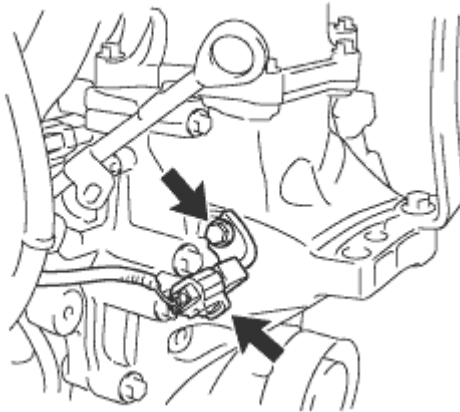

Y

1. Disconnect the connector.
2. Remove the bolt and radio setting condenser.

105. REMOVE KNOCK SENSOR

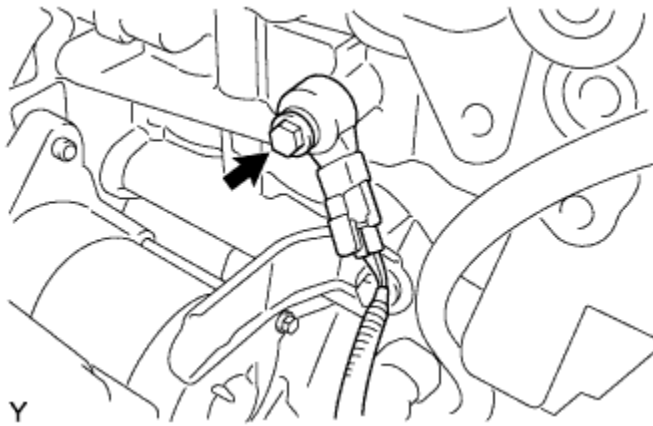

1. Disconnect the connector.
2. Remove the bolt and knock sensor.

106. REMOVE ENGINE WIRE



1. Remove the bolt and separate the engine wire harness.
2. Separate the wire harness clamps and remove the engine wire.

107. REMOVE HEATER WATER OUTLET HOSE A(FROM HEATER UNIT)

108. REMOVE HEATER WATER INLET HOSE A

109. REMOVE RADIATOR HOSE NO. 1

110. REMOVE RADIATOR HOSE NO. 2

ENGINE ASSEMBLY > INSTALLATION

1. INSTALL RADIATOR HOSE NO. 1

2. INSTALL RADIATOR HOSE NO. 2

3. INSTALL HEATER WATER OUTLET HOSE A (FROM HEATER UNIT)

4. INSTALL HEATER WATER INLET HOSE A

5. INSTALL ENGINE WIRE

6. INSTALL KNOCK SENSOR

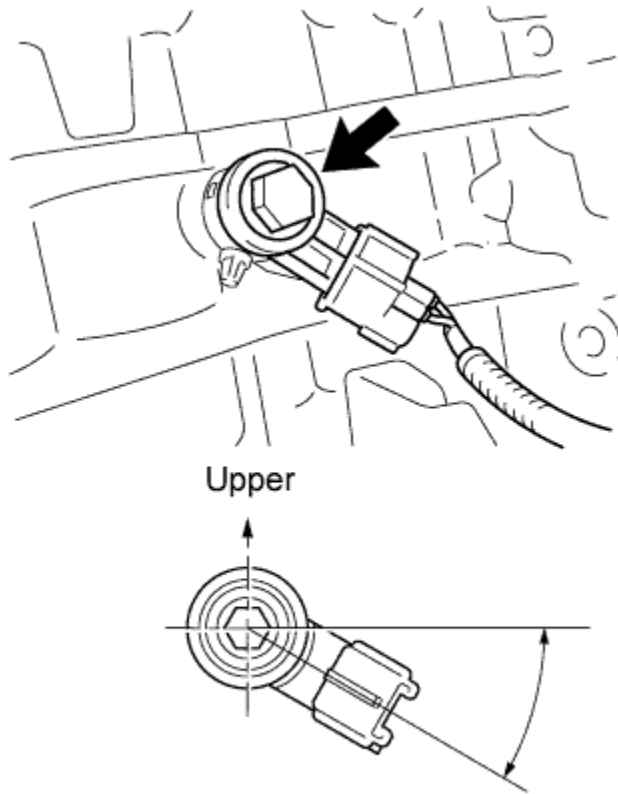

Y

1. Install the knock sensor with the bolt.

Torque:

20 N*m { 204 kgf*cm , 15 ft.*lbf }

HINT:

It is acceptable for the sensor to be tilted 0 to 45°.

2. Connect the connector.

7. INSTALL RADIO SETTING CONDENSER

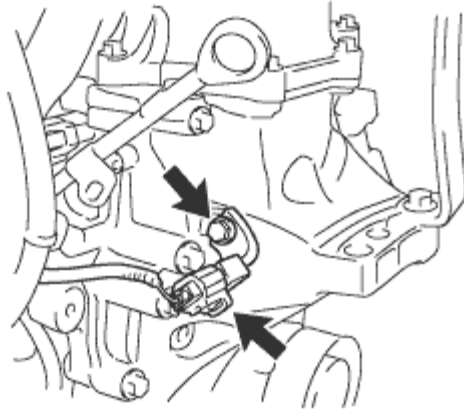

Y

1. Install condenser with a bolt.

Torque:
10 N*m { 102 kgf*cm , 7 ft.*lbf }

2. Connect the connector.

8. INSTALL FUEL INJECTOR ASSEMBLY

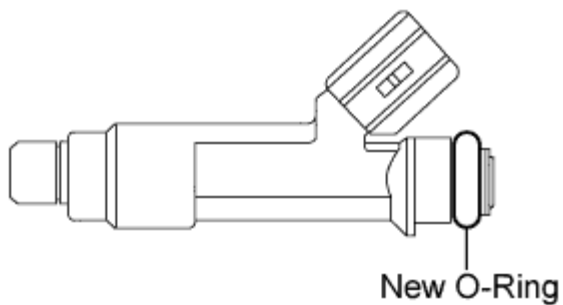

Y

1. Apply a light coat of grease or gasoline to a new O-ring, and install it onto the injector.
2. Apply a light coat of grease or gasoline to the place where the delivery pipe touches the O-ring.

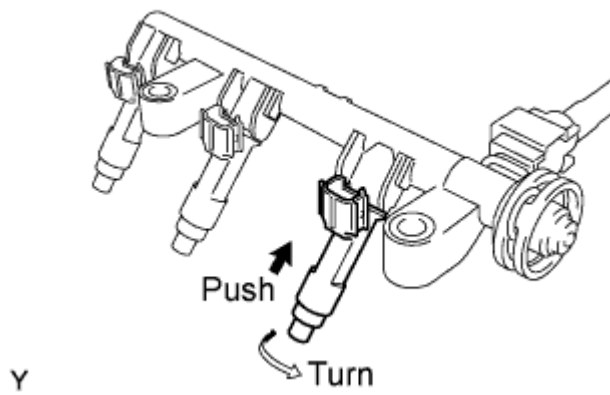

3. Push the fuel injector while twisting it back and forth to install it in the fuel delivery pipe.

NOTICE:

- Do not twist the O-ring.
- Check that the fuel injector turns smoothly after installing it. If it does not, reinstall it with a new O-ring.

4. Position the injector connectors so that they face upward.

9. INSTALL FUEL DELIVERY PIPE

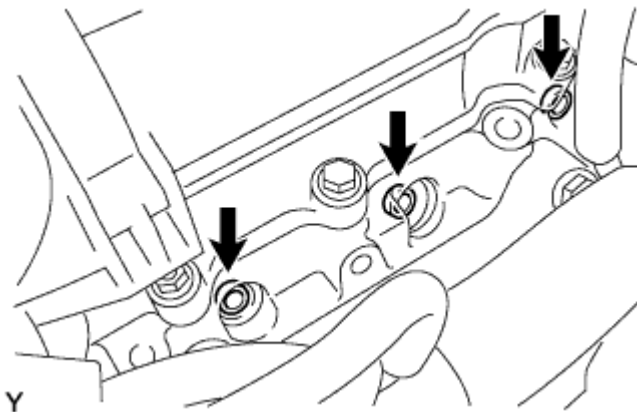

1. Install 3 new fuel injector vibration insulators to the cylinder head.

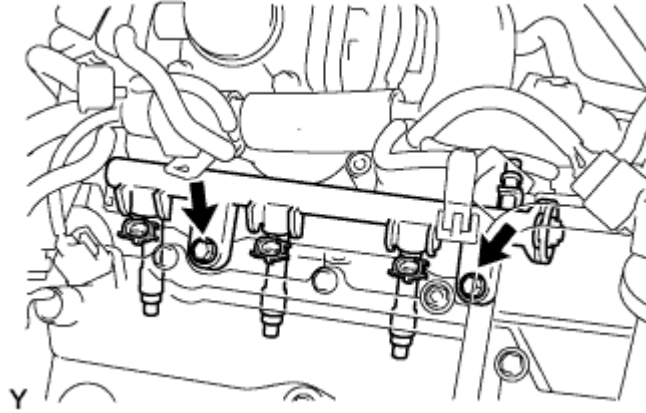

2. Place the fuel delivery pipe and the 3 fuel injectors together to the cylinder head.

NOTICE:

Do not drop the fuel injectors when installing the fuel delivery pipe .

3. Provisionally install the 2 bolts which are used to hold the fuel delivery pipe to the cylinder head.

NOTICE:

Check that the fuel injector turns smoothly after installing it. If does not, reinstall it with a new O-ring.

4. Tighten the 2 bolts which are used to hold the fuel delivery pipe to the cylinder head.

Torque:

27 N*m { 275 kgf*cm , 20 ft.*lbf }

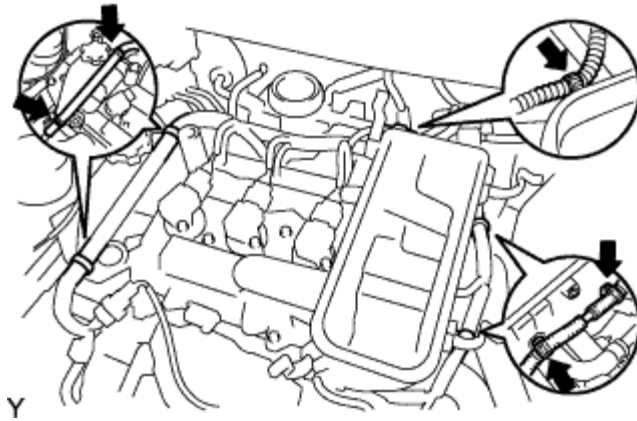

5. Engage the 5 clamps and install the engine wire harness onto the cylinder head cover.

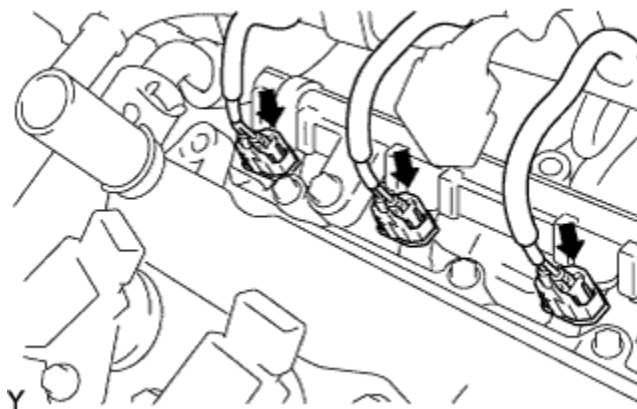

6. Connect the 3 injector connectors.

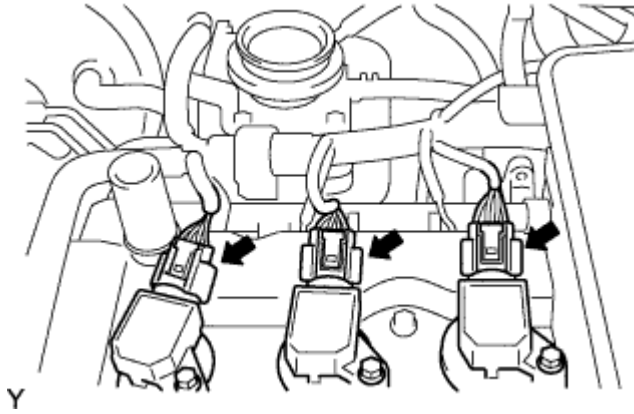

7. Connect the 3 ignition coil connectors.

10. INSTALL INTAKE MANIFOLD

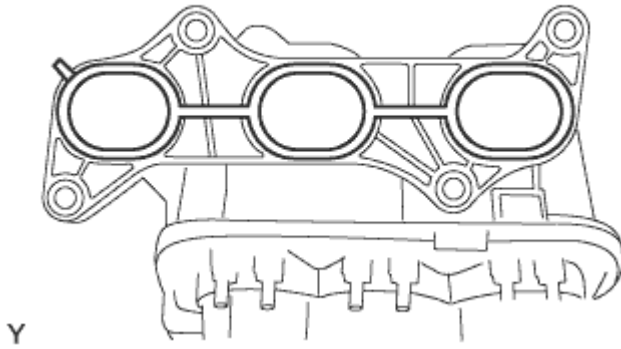

1. Install the new gasket.

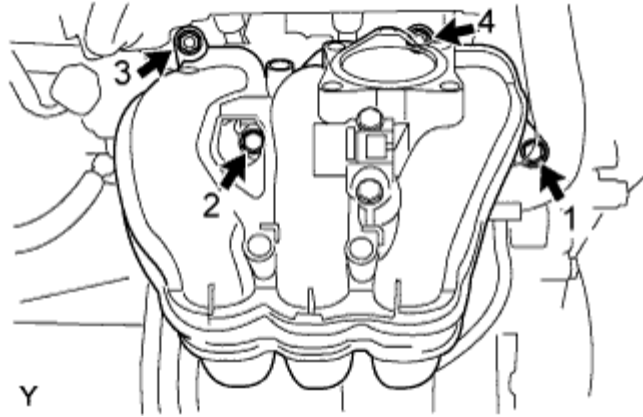

2. Install the intake manifold with the 3 bolts and 2 nuts in the order shown in the illustration.

Torque:
30 N*m { 306 kgf*cm , 22 ft.*lbf }

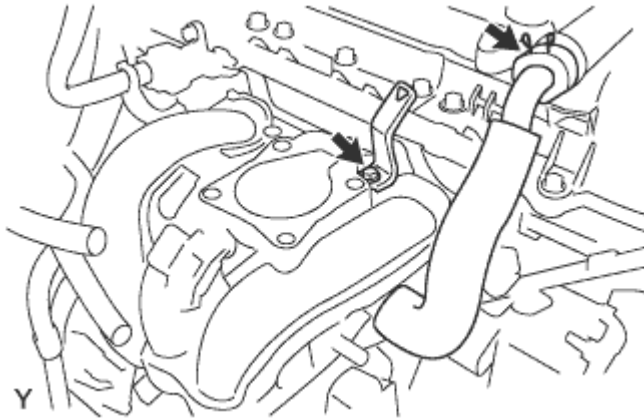

3. Install the wire harness clamp with the bolt.

Torque:
8.4 N*m { 85 kgf*cm , 74 in.*lbf }

4. Connect the ventilation hose.

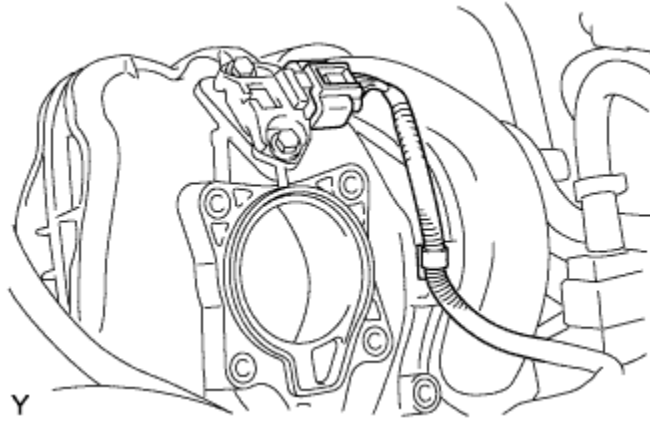

5. Connect the manifold absolute pressure sensor connector and the wire harness clamp.

11. INSTALL INTAKE MANIFOLD STAY



1. Install the intake manifold stay with the 2 bolts.

Torque:
21 N*m { 214 kgf*cm , 16 ft.*lbf }

12. INSTALL THROTTLE WITH MOTOR BODY ASSEMBLY

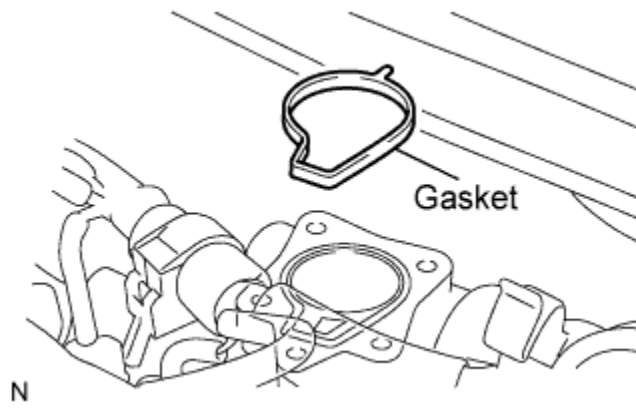

1. Install the new throttle body gasket.

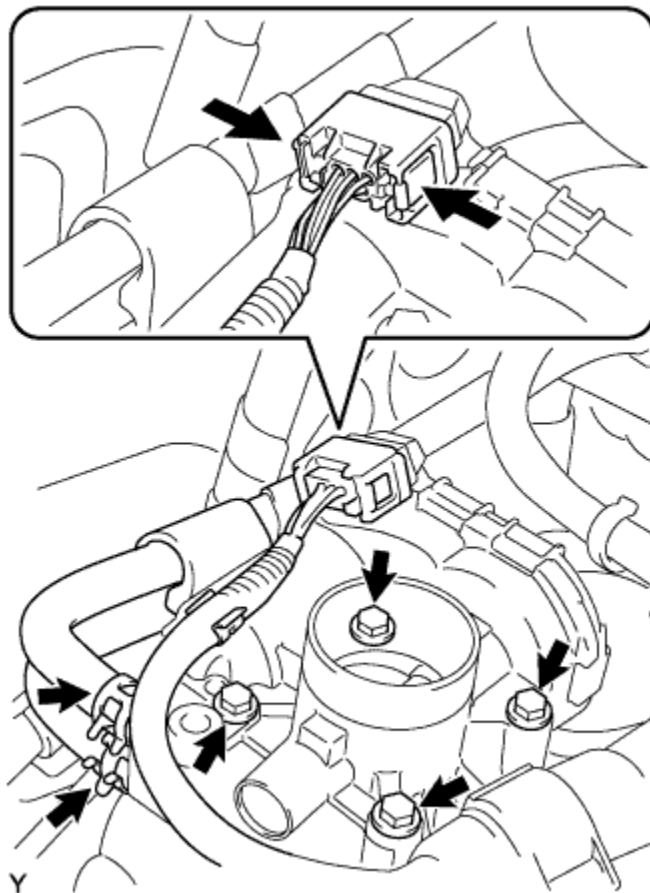

2. Install the throttle body with the 4 bolts.

Torque:

10 N*m { 102 kgf*cm , 7.4 ft.*lbf }

NOTICE:

Do not bend the throttle body gasket while installing the throttle body.

3. Connect the 2 water by-pass hoses.
4. Connect the connector and the wire harness clamp.

13. INSTALL EXHAUST MANIFOLD ASSEMBLY



1. Install the new gasket.
2. Install the exhaust manifold with the 2 bolts and 2 nuts in the order shown in the illustration.

Torque:

24 N*m { 245 kgf*cm , 18 ft.*lbf }

14. INSTALL MANIFOLD STAY

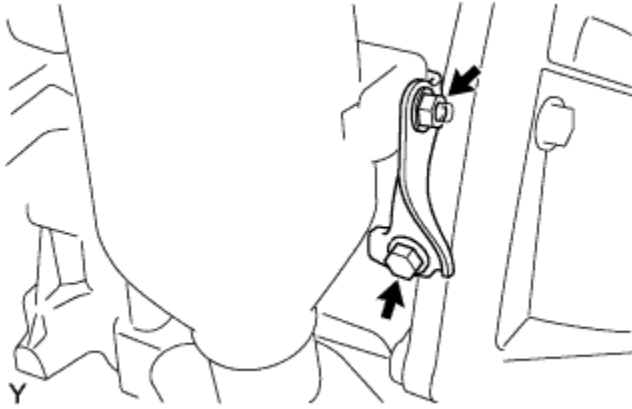

1. Install the manifold stay with the bolt and nut.

Torque:

24 N*m { 245 kgf*cm , 18 ft.*lbf }

15. INSTALL DUTY VACUUM SWITCHING VALVE

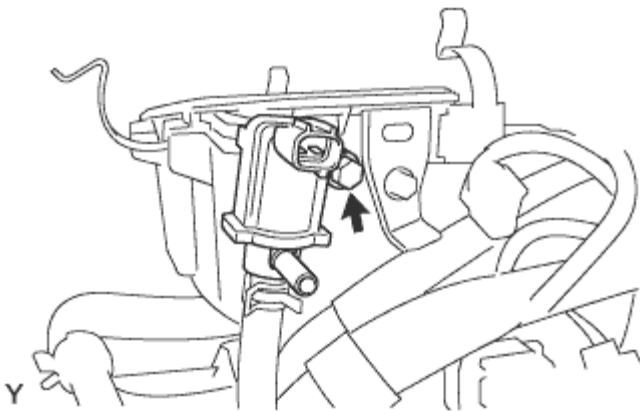

1. Install the duty vacuum switching valve with the bolt.

Torque:

8.8 N*m { 90 kgf*cm , 78 in.*lbf }

2. Connect the connector.

16. INSTALL IGNITION COIL NO. 1

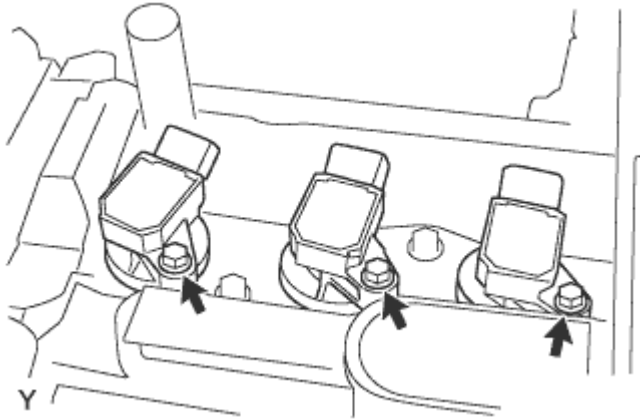

1. Install the ignition coil with the 3 bolts.

Torque:
9.2 N*m { 94 kgf*cm , 81 in.*lbf }

2. Connect the 3 connectors.

17. INSTALL FLYWHEEL ASSEMBLY

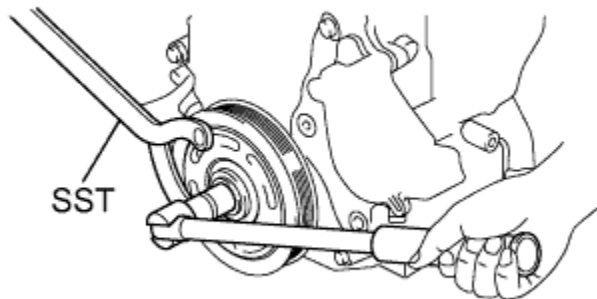

1. Hold the crankshaft with SST.

SST
09960-10010 (09962-01000, 09963-01000)

2. Clean the 6 bolts and their holes.

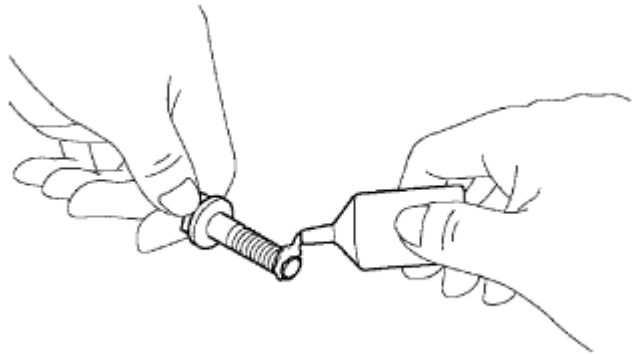

Y

A57108

3. Apply adhesive to the 2 or 3 end threads of the bolts.

Adhesive:
Part No. 08833-00070, THREE BOND 1324 or equivalent

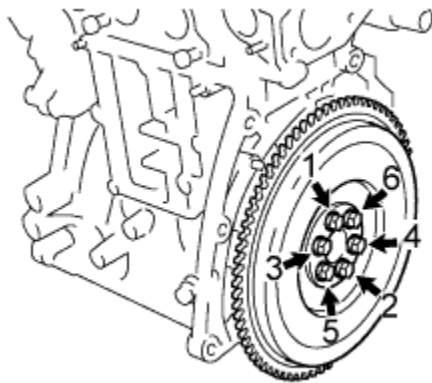

N

4. Install the flywheel with the 6 bolts in the order shown in the illustration.

Torque:
78 N*m { 796 kgf*cm , 58 ft.*lbf }

18. INSTALL CLUTCH DISC ASSEMBLY

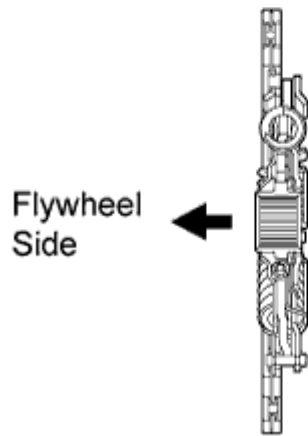
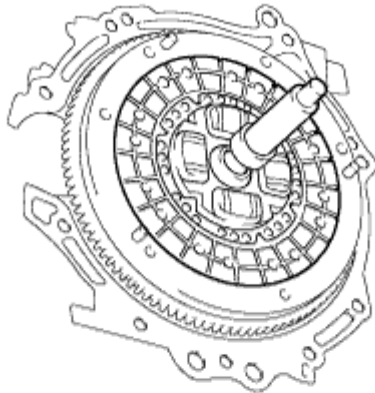

P

1. Insert SST into the clutch disc, and then insert them into the flywheel.

SST
09301-00210

NOTICE:

Insert the clutch disc in the correct direction.

19. INSTALL CLUTCH COVER ASSEMBLY

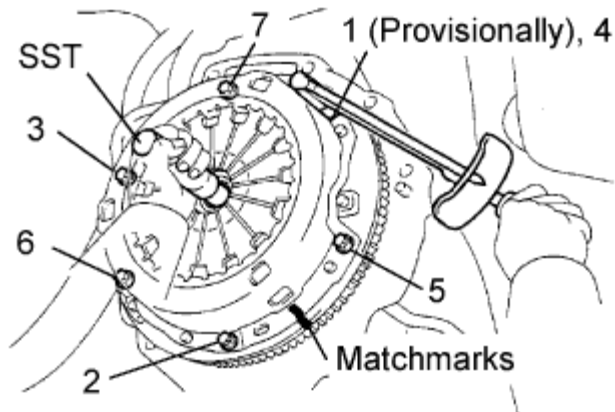

1. Align the matchmark on the clutch cover with the one on the flywheel.
2. Tighten the 6 bolts uniformly in the order shown in the illustration, starting with the bolt located near the knock pin at the top.

Torque:

19 N*m { 195 kgf*cm , 14 ft.*lbf }

HINT:

After checking that the disc is in the center, gently move SST up and down, right and left to tighten the bolts.

SST

09301-00210

20. INSTALL MANUAL TRANSAXLE ASSEMBLY

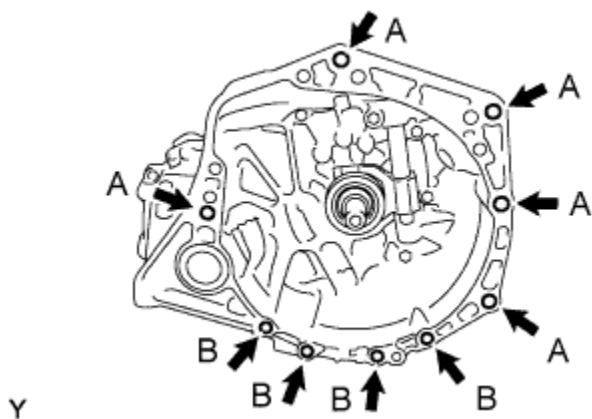

1. Align the input shaft with the clutch disc and install the manual transaxle onto the engine.

2. Install the 9 bolts.

Torque:

Bolt A:

64 N*m { 653 kgf*cm , 47 ft.*lbf }

Bolt B:

39 N*m { 398 kgf*cm , 29 ft.*lbf }

NOTICE:

Insert a dowel pin securely into the dowel hole so that the end of face of the transaxle assembly is in close contact with the engine assembly before tightening the bolts to fix the engine and transaxle.

21. INSTALL ENGINE MOVING CONTROL ROD

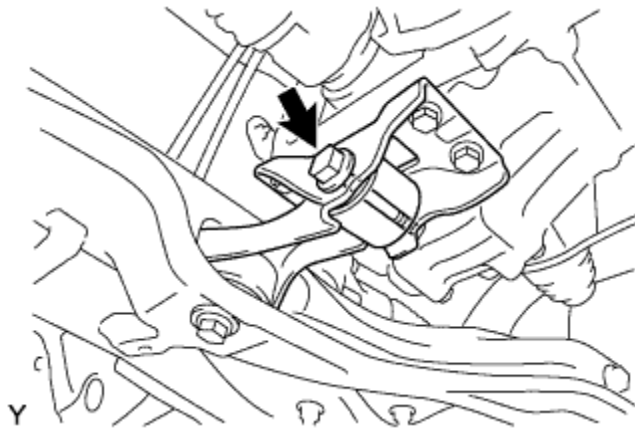

1. Install the engine moving control rod with the bolt.

Torque:

120 N*m { 1,224 kgf*cm , 89 ft.*lbf }

22. INSTALL STARTER ASSEMBLY (for 0.8 kW Type)

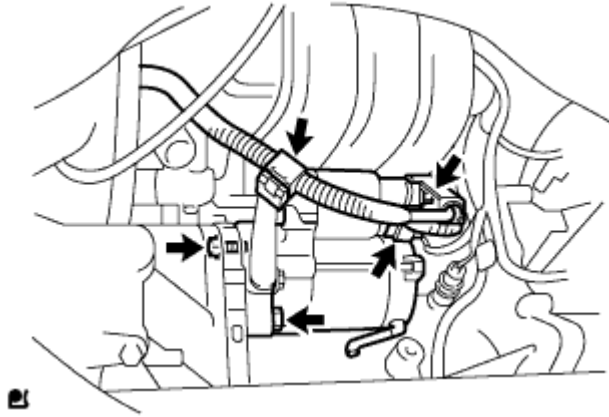

1. Install the starter assembly with the 2 bolts.

Torque:
 $37 \text{ N}\cdot\text{m}$ { $377 \text{ kgf}\cdot\text{cm}$, $27 \text{ ft}\cdot\text{lbf}$ }

2. Connect the connector.
3. Connect terminal 30 with the nut.

Torque:
 $9.8 \text{ N}\cdot\text{m}$ { $100 \text{ kgf}\cdot\text{cm}$, $7.2 \text{ ft}\cdot\text{lbf}$ }

4. Close the terminal cap.

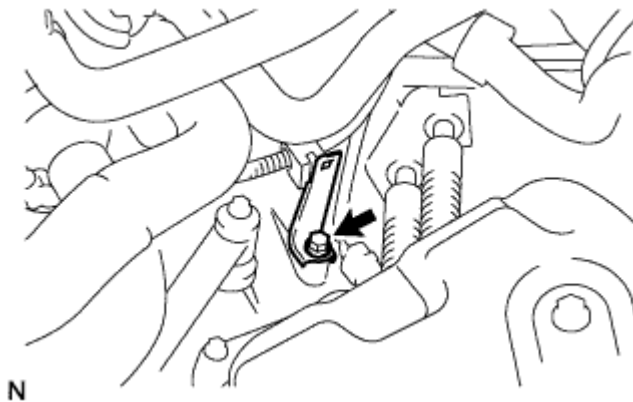

5. Install the wire harness bracket with the bolt.

Torque:
 $8 \text{ N}\cdot\text{m}$ { $82 \text{ kgf}\cdot\text{cm}$, $71 \text{ in}\cdot\text{lbf}$ }

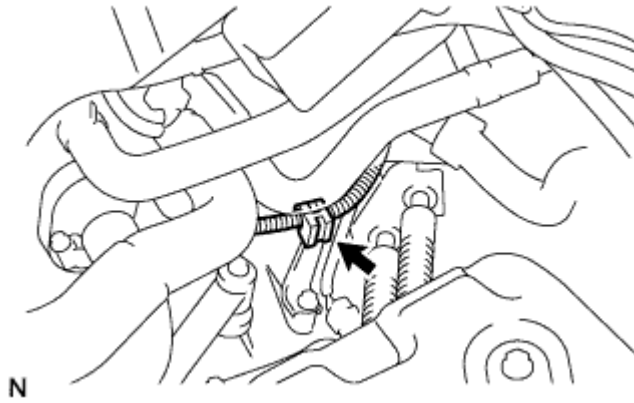

6. Install the harness clamp.

23. INSTALL STARTER ASSEMBLY (for 1.0 kW Type)

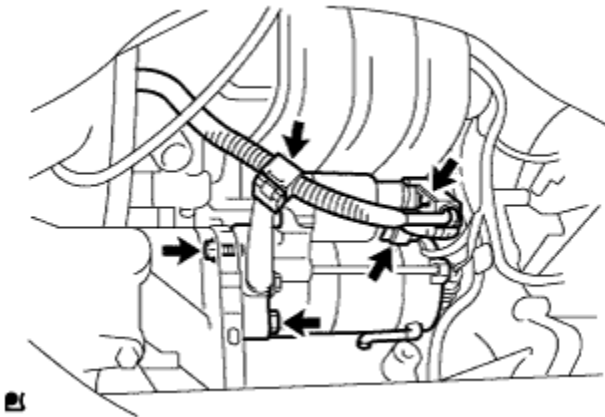

1. Install the starter assembly with the 2 bolts.

Torque:
 $37 \text{ N}\cdot\text{m} \{ 377 \text{ kgf}\cdot\text{cm}, 27 \text{ ft.}\cdot\text{lbf} \}$

2. Connect the connector.
3. Connect terminal 30 with the nut.

Torque:
9.8 N*m { 100 kgf*cm , 7.2 ft.*lbf }

4. Close the terminal cap.

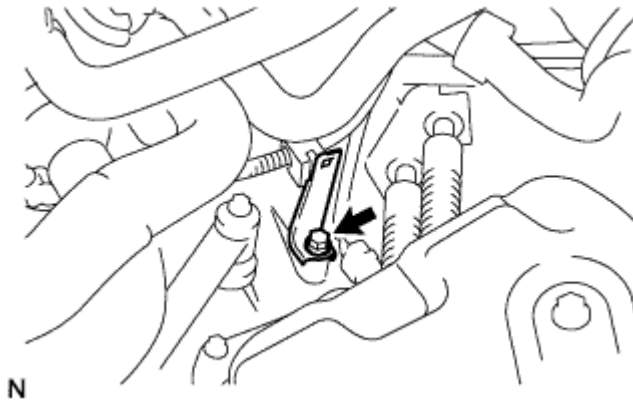

5. Install the wire harness bracket with the bolt.

Torque:
8 N*m { 82 kgf*cm , 71 ft.*lbf }

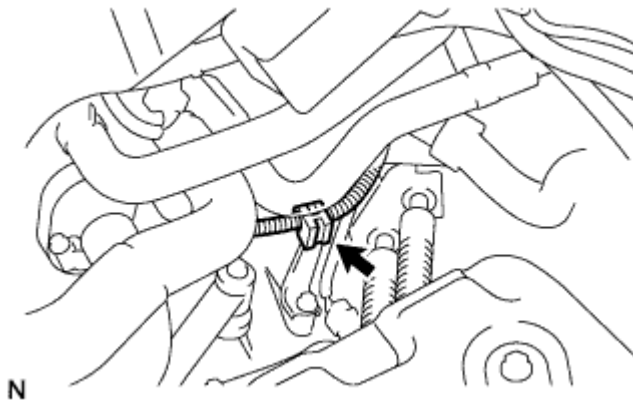

6. Install the harness clamp.

24. INSTALL FLYWHEEL HOUSING SIDE COVER (for 0.8 kW Type)

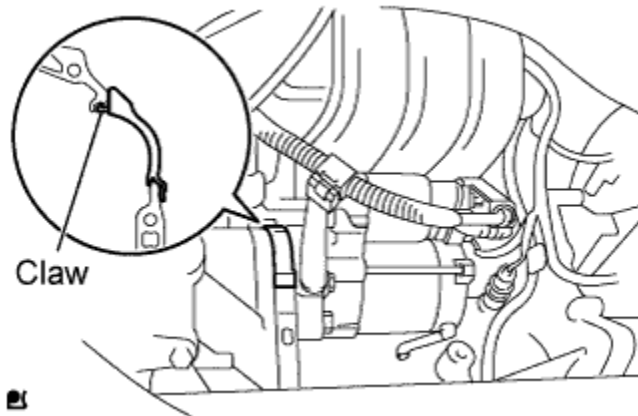

1. Insert the protruding portion into the end of the cylinder block and while pushing it along the cylinder block, fit the claw into the cylinder block.

NOTICE:

- Make sure that the claw makes a click sound, indicating that it fits tightly.
- Replace the claw with a new one if it does not fit tightly or is deformed.

25. INSTALL FLYWHEEL HOUSING SIDE COVER (for 1.0 kW Type)

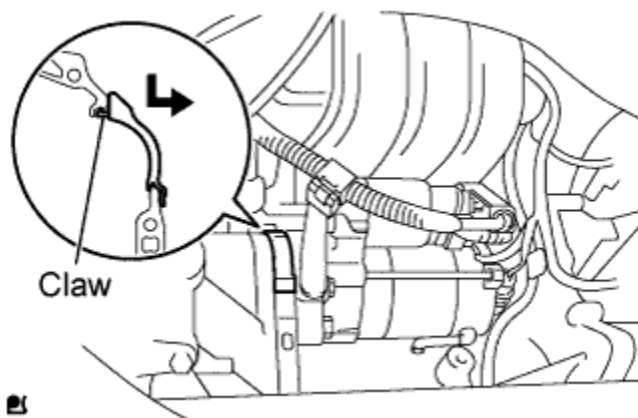

1. Insert the protruding portion into the end of the cylinder block and while pushing it along the cylinder block, fit the claw into the cylinder block.

NOTICE:

- Make sure that the claw makes a click sound, indicating that it fits tightly.
- Replace the claw with a new one if it does not fit tightly or is deformed.

26. INSTALL ENGINE ASSEMBLY WITH TRANSAXLE

1. Set the engine assembly with transaxle and the front suspension cross member on the engine lifter.
2. Operate the engine lifter and lift the engine assembly with transaxle and the front suspension cross member into the position where the engine mounting insulator RH and LH can be installed.

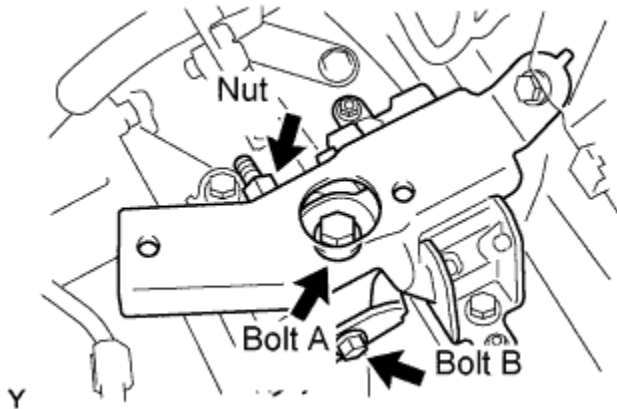

3. Install the engine mounting insulator LH with bolt B and the nut.

Torque:
52 N*m { 530 kgf*cm , 38 ft.*lbf }

4. Install the engine mounting insulator LH with bolt A.

Torque:
64 N*m { 653 kgf*cm , 47 ft.*lbf }

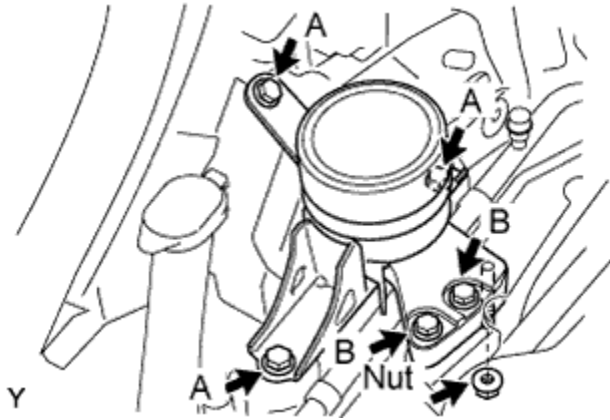

5. Provisionally install the engine mounting insulator RH with the 5 bolts and nut.
6. Tighten the 5 bolts and nut.

Torque:

Bolt A:

45 N*m { 460 kgf*cm , 33 ft.*lbf }

Bolt B:

52 N*m { 530 kgf*cm , 38 ft.*lbf }

Nut:

52 N*m { 530 kgf*cm , 38 ft.*lbf }

7. Operate the engine lifter and provisionally install the engine assembly with transaxle and the front suspension cross member onto the vehicle with the 6 bolts.

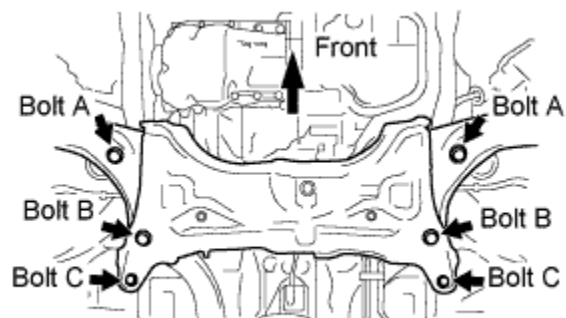

8. Insert SST into the datum holes of the front suspension cross member RH and LH alternately and tighten bolts A, B and C on both sides in several steps.

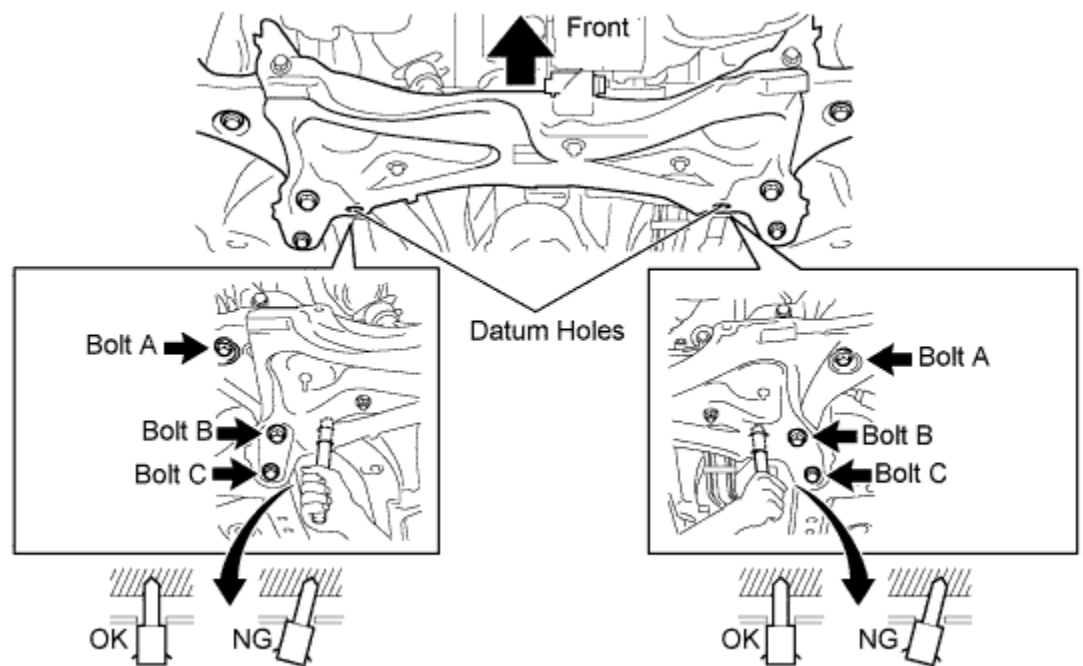

SST
09670-00010
Torque:
Bolt A:
70 N*m { 714 kgf*cm , 52 ft.*lbf }
Bolt B:
160 N*m { 1,631 kgf*cm , 118 ft.*lbf }
Bolt C:
95 N*m { 969 kgf*cm , 70 ft.*lbf }

CAUTION:

- Insert SST into the datum holes vertically.
- If impossible to insert SST vertically, loosen all the bolts and then insert SST again.

27. INSTALL WITH PULLEY COMPRESSOR ASSEMBLY (w/ Air Conditioning System)

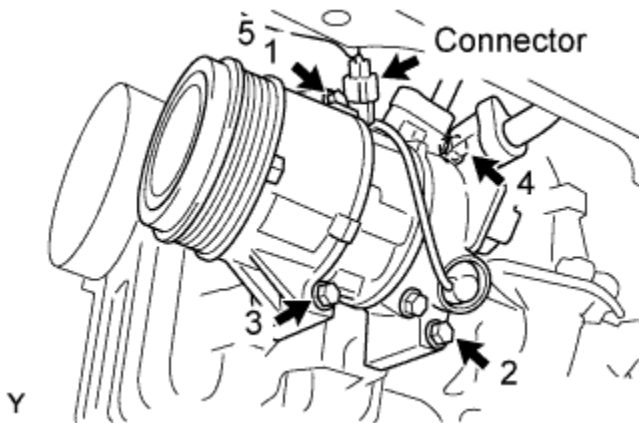

1. Install the compressor with the 4 bolts in the order shown in the illustration.

Torque:
25 N*m { 250 kgf*cm , 18 ft.*lbf }

2. Connect the connector.

28. INSTALL ENGINE WIRE

29. INSTALL ECM

1. Connect the ECM connector.

30. INSTALL STEERING COLUMN HOLE COVER SUB-ASSEMBLY NO. 1

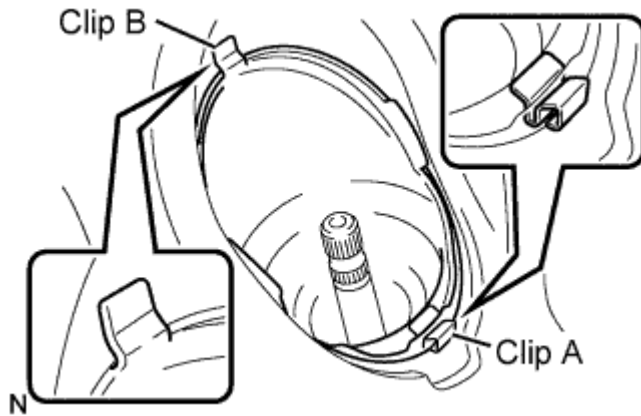

1. Install clip B onto the vehicle body and install the steering column hole cover onto the vehicle body with clip A.

NOTICE:

Fit the lip of steering column hole cover correctly onto the dash panel.

31. INSTALL STEERING INTERMEDIATE SHAFT ASSEMBLY NO. 2

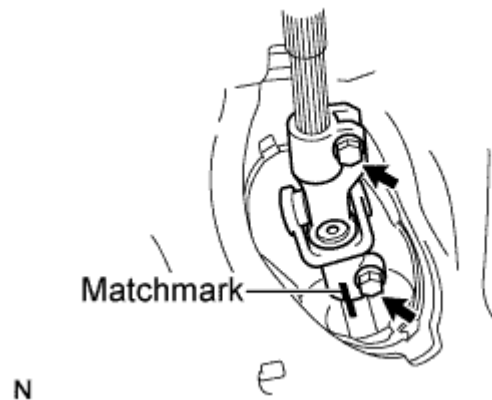

1. Align the matchmarks and install steering intermediate shaft onto the steering gear with the 2 bolts.

Torque:

28 N*m { 286 kgf*cm , 21 ft.*lbf }

32. INSTALL COLUMN HOLE COVER SILENCER SHEET

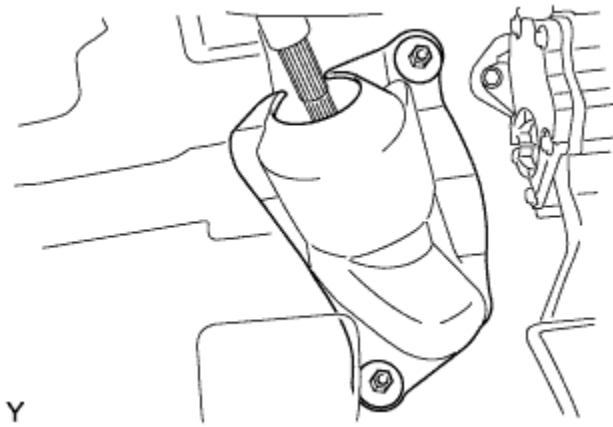

1. Install the column hole cover silencer sheet with the 2 clips.

33. INSTALL FRONT DRIVE SHAFT ASSEMBLY LH

1. for Automatic Transaxle:
 1. Coat the spline of the inboard joint with ATF.
2. for Manual Transaxle:
 1. Coat the spline of the inboard joint with gear oil.

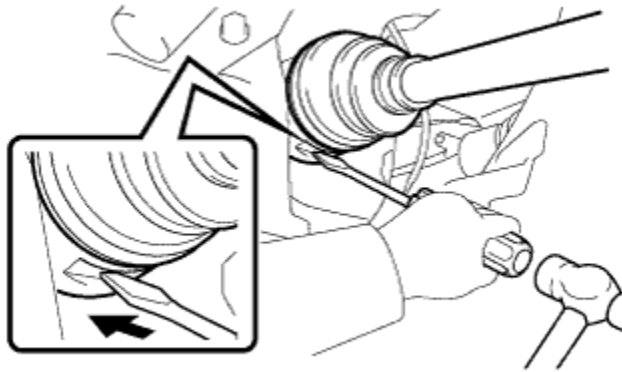

P

3. Align the inboard joint splines and install the drive shaft with a screwdriver and hammer.

NOTICE:

- Face the cut area of the front drive inboard joint hole snap ring downward.
- Do not damage the oil seal.
- Do not damage the inboard joint boot.

HINT:

Confirm whether the drive shaft is securely driven in by checking the reaction force and sound.

34. INSTALL FRONT DRIVE SHAFT ASSEMBLY RH

HINT:

The installation procedure for the RH side is the same as that for the LH side.

35. INSTALL FRONT AXLE ASSEMBLY LH

1. Push the front axle out of the vehicle to align the spline of the drive shaft with the front axle and insert the front axle.

NOTICE:

- Do not push the front axle further out of the vehicle than is necessary.
- Do not damage the outboard joint boot.
- Check for any foreign matter on the speed sensor rotor and insertion part.
- Do not damage the speed sensor rotor.

36. INSTALL FRONT AXLE ASSEMBLY RH

HINT:

The installation procedure for the RH side is the same as that for the LH side.

37. INSTALL FRONT STABILIZER LINK ASSEMBLY LH

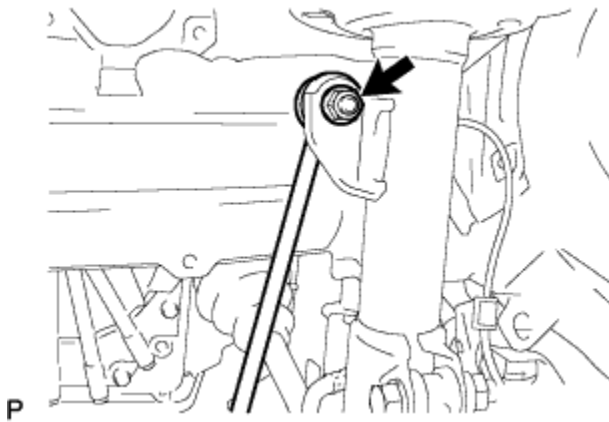

1. Install the stabilizer link with the nut.

Torque:

74 N*m { 755 kgf*cm , 55 ft.*lbf }

HINT:

If the ball joint turns together with the nut, use a socket hexagon wrench 6 to hold the stud.

38. INSTALL FRONT STABILIZER LINK ASSEMBLY RH

HINT:

The installation procedure for the RH side is the same as that for the LH side.

39. INSTALL TIE ROD END SUB-ASSEMBLY LH

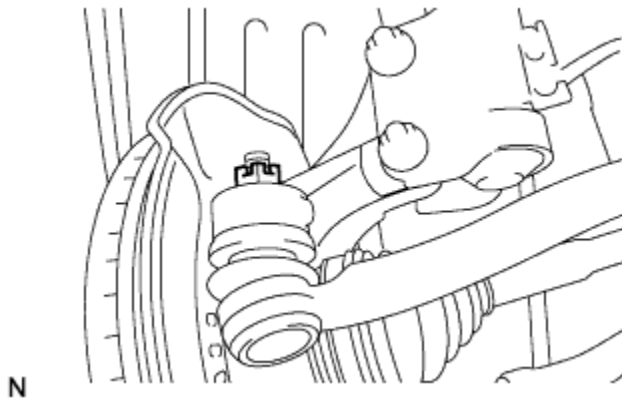

1. Install the tie rod end onto the steering knuckle with a new castle nut.

Torque:

49 N*m { 500 kgf*cm , 36 ft.*lbf }

NOTICE:

If the holes for the clip are not aligned, tighten the nut by a further turn of up to 60°.

2. Install a new cotter pin.

40. INSTALL TIE ROD END SUB-ASSEMBLY RH

HINT:

The installation procedure for the RH side is the same as that for the LH side.

41. INSTALL FRONT SUSPENSION ARM SUB-ASSEMBLY LOWER NO. 1 LH

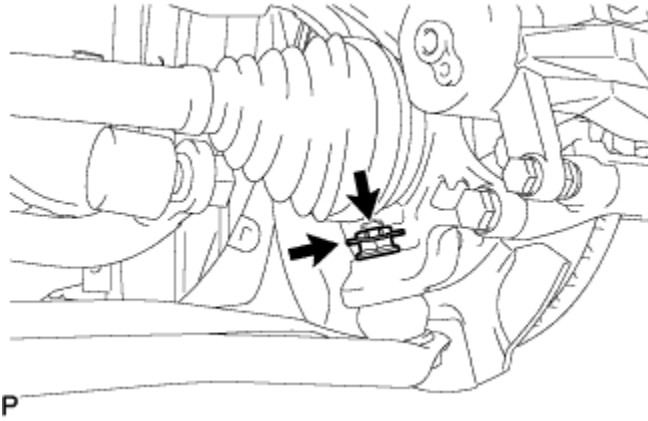

1. Install the lower arm onto the steering knuckle with a new castle nut.

Torque:

98 N*m { 1,000 kgf*cm , 72 ft.*lbf }

NOTICE:

If the holes for the clip are not aligned, tighten the nut by a further turn of up to 60°.

2. Install a new clip.

42. INSTALL FRONT SUSPENSION ARM SUB-ASSEMBLY LOWER NO. 1 RH

HINT:

The installation procedure for the RH side is the same as that for the LH side.

43. INSTALL SPEED SENSOR FRONT LH

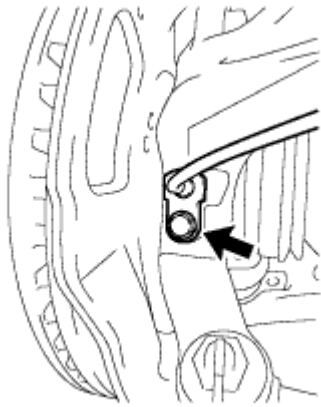

P

1. Install the speed sensor onto the steering knuckle with the bolt.

Torque:

8.5 N*m { 87 kgf*cm , 75 in.*lbf }

NOTICE:

- Check that the speed sensor tip and installation portion are free of foreign matter.
- Install the speed sensor without turning it from its original installation angle.

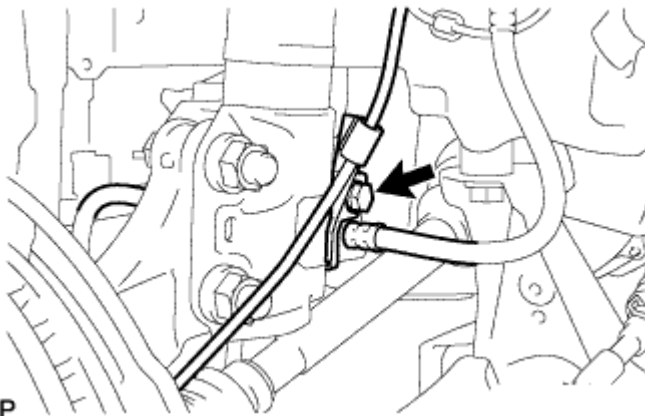

P

2. Install the flexible hose and speed sensor with the bolt.

Torque:

29 N*m { 300 kgf*cm , 22 ft.*lbf }

NOTICE:

Install the flexible hose and speed sensor without twisting them.

44. INSTALL SPEED SENSOR FRONT RH

HINT:

The installation procedure for the RH side is the same as that for the LH side.

45. INSTALL FRONT AXLE SHAFT LH NUT

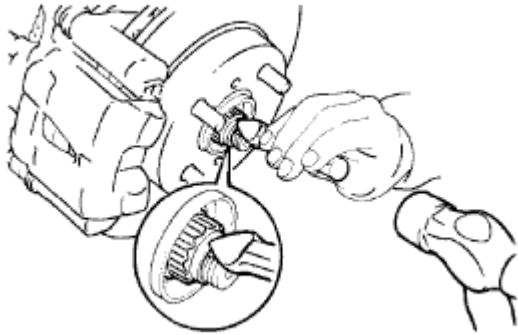

T

C57566

1. Using a 30 mm socket wrench, install a new axle hub nut.

Torque:

216 N*m { 2,203 kgf*cm , 160 ft.*lbf }

2. Using a chisel and hammer, caulk the axle hub nut.

46. INSTALL FRONT AXLE SHAFT RH NUT

HINT:

The installation procedure for the RH side is the same as that for the LH side.

47. INSTALL FUEL TUBE SUB-ASSEMBLY

1. Connect the fuel tube connector and fuel pipe, and install fuel pipe clamp No. 1.

CAUTION:

Align the fuel tube connector with the pipe, then push the fuel tube connector in until the retainer makes a click sound. If the connection is tight, apply a small amount of engine oil to the tip of the pipe. After connecting, pull the pipe and connector to make sure that they are securely connected.

48. CONNECT HEATER WATER INLET HOSE A

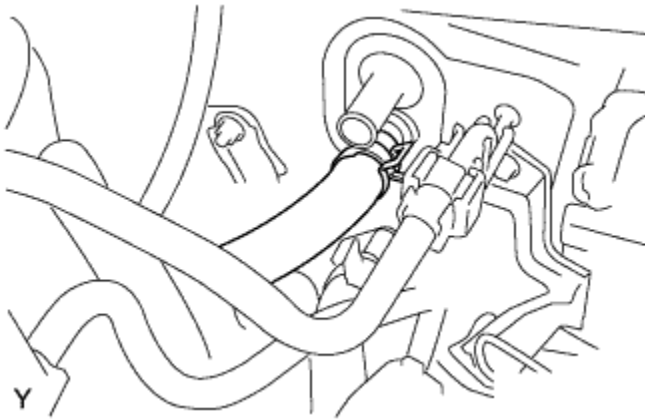

49. CONNECT HEATER WATER OUTLET HOSE A(FROM HEATER UNIT)

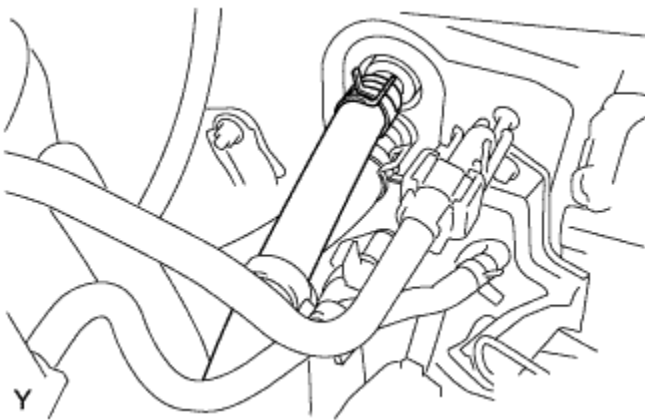

50. CONNECT RADIATOR HOSE NO. 1

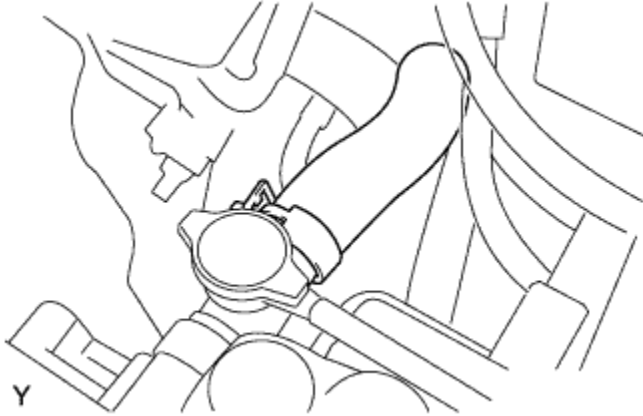

51. CONNECT RADIATOR HOSE NO. 2

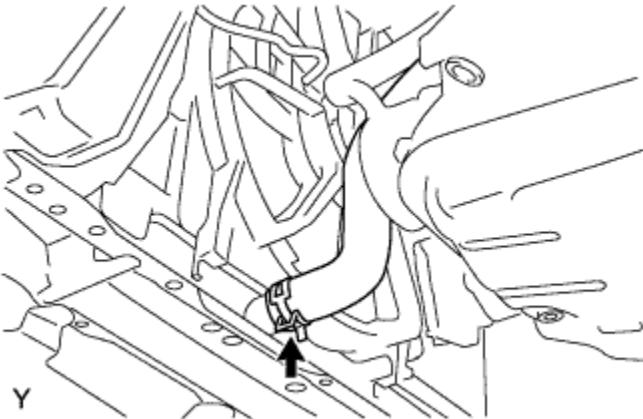

52. INSTALL TRANSMISSION CONTROL CABLE ASSEMBLY

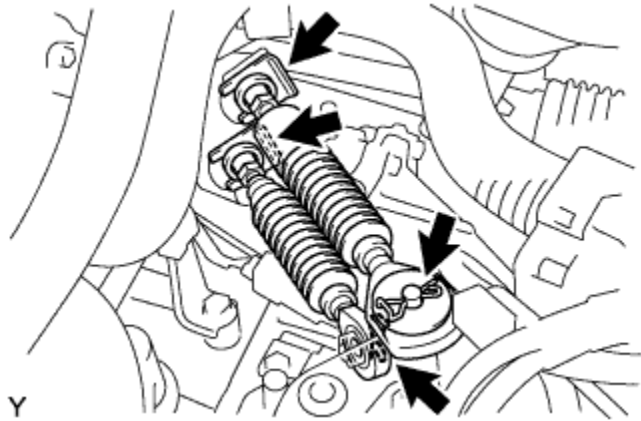

1. Connect the 2 cable ends, and install the 2 washers and the 2 clips.
2. Install the 2 new clips onto the control cable bracket.

| |
|--|
| 53. INSTALL CLUTCH RELEASE CYLINDER ASSEMBLY |
|--|

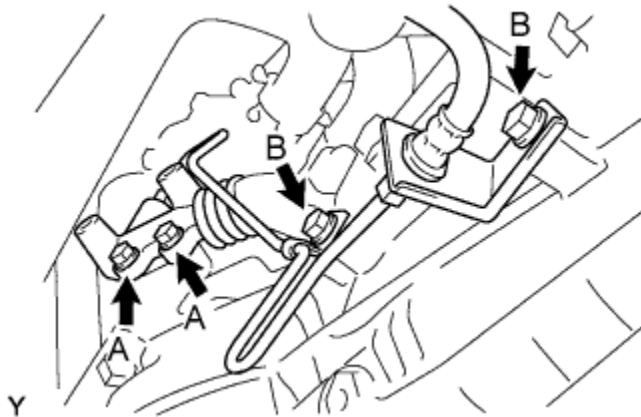

1. Install the clutch release cylinder and clutch pipe with the 4 bolts.

Torque:

Bolt A:

12 N*m { 120 kgf*cm , 8.7 ft.*lbf }

Bolt B:

19 N*m { 194 kgf*cm , 14 ft.*lbf }

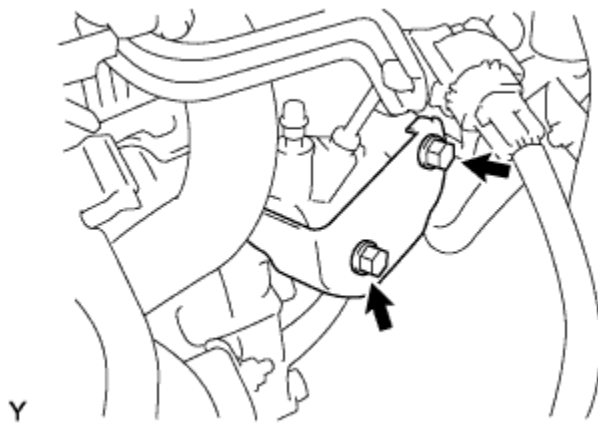

2. Install the release cylinder heat insulator with the 2 bolts.

Torque:

12 N*m { 120 kgf*cm , 8.7 ft.*lbf }

54. CONNECT BOOSTER VACUUM TUBE

1. Connect the booster vacuum hose the intake manifold.

55. CONNECT FUEL VAPOR FEED HOSE NO. 1



56. INSTALL FAN BELT ADJUSTING BAR

1. Install the fan belt adjusting bar with the bolt.

Torque:

34 N*m { 347 kgf*cm , 25 ft.*lbf }

57. INSTALL GENERATOR ASSEMBLY

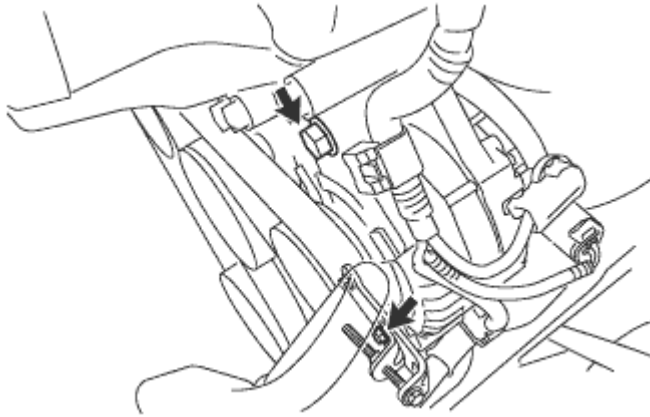

1. Provisionally install the generator with the 2 bolts.

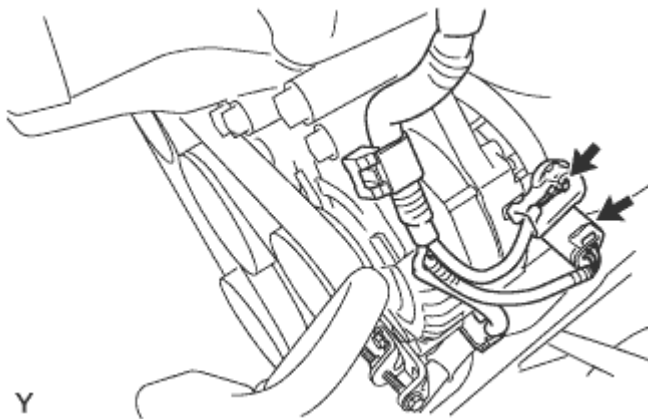

2. Install the terminal B with the nut.

Torque:

$7.8 \text{ N}\cdot\text{m}$ { $80 \text{ kgf}\cdot\text{cm}$, $69 \text{ in}\cdot\text{lbf}$ }

3. Connect the connector.
4. Engage the 2 clamps onto the generator.

| |
|--------------------------------------|
| 58. INSTALL FAN AND GENERATOR V BELT |
|--------------------------------------|

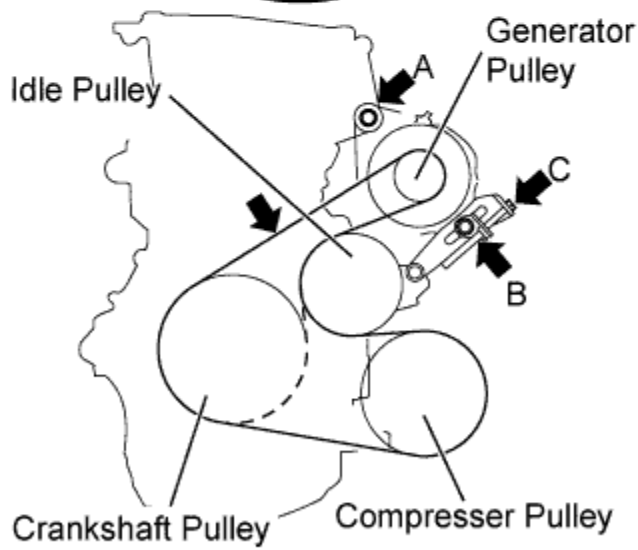
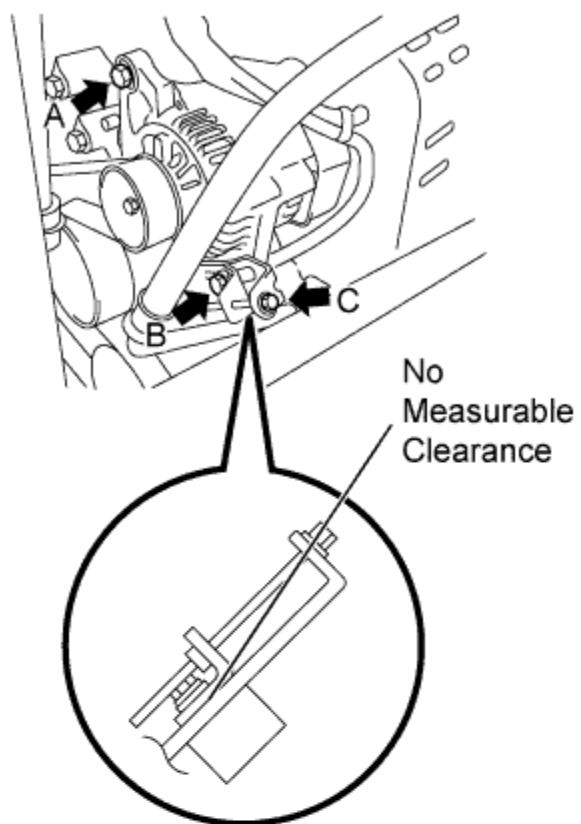

—— w/ Air Conditioner
 - - - - w/o Air Conditioner

c

1. Install the fan and generator V belt.

2. Gently tighten bolt B until there is no measurable clearance.
3. Turn bolt C to adjust the tension of the fan and generator V belt.
4. Inspect the fan and generator V belt.
5. Tighten bolt B.

Torque:

34 N*m { 347 kgf*cm , 25 ft.*lbf }

6. Tighten bolt A.

Torque:

54 N*m { 551 kgf*cm , 40 ft.*lbf }

7. Visually check the generator wiring and listen for abnormal noise.
 1. Check that the wiring is in good condition.
 2. Check that there is no abnormal noise from the generator while the engine is running.



Correct



Wrong Wrong

8. Inspect the discharge warning light circuit.
 1. Turn the ignition switch to the ON position. Check that the discharge warning light illuminates.
 2. Start the engine. Check that the light goes off.

59. INSTALL VENTILATION HOSE NO. 2

1. Install the ventilation hose No. 2 with the clamp.

60. INSTALL AIR CLEANER FILTER ELEMENT SUB-ASSEMBLY

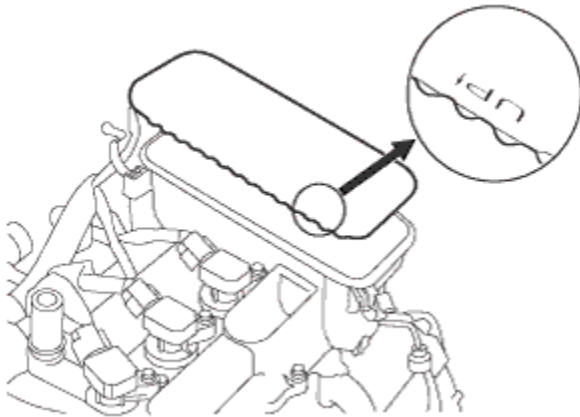

1. Install the air cleaner filter element as shown in the illustration.

61. INSTALL AIR CLEANER CAP SUB-ASSEMBLY

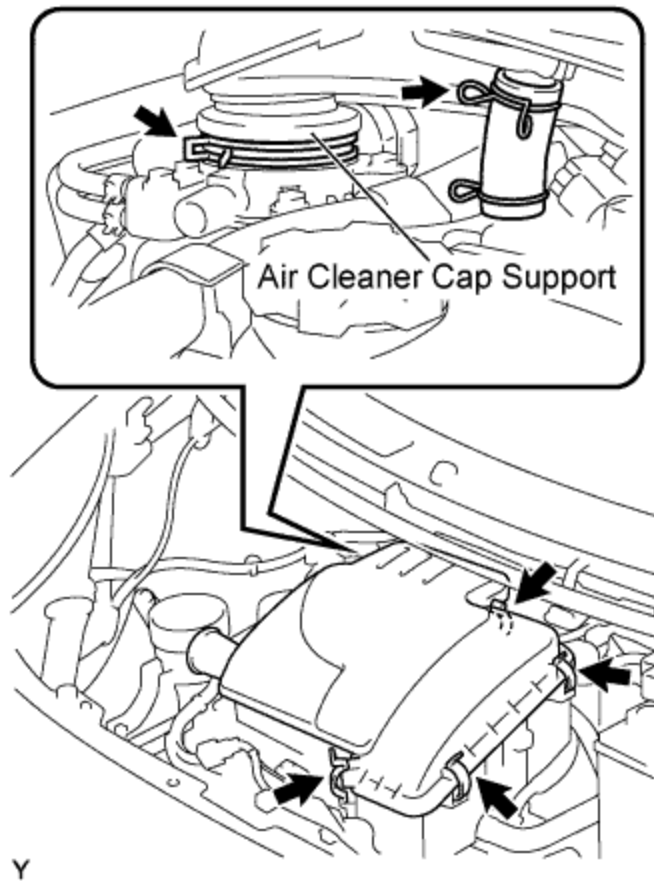

Y

1. Install the air cleaner cap with the 2 clamps.
2. Tighten the 4 clamps.

62. INSTALL COWL TOP PANEL OUTER

1. Install the cowl top panel outer with the 9 bolts.

Torque:
6.5 N*m { 66 kgf*cm , 58 in.*lbf }

2. Engage the clamp and install the wiper motor connector wire harness.

63. INSTALL COWL TO REGISTER DUCT SUB-ASSEMBLY NO. 2

for LHD:

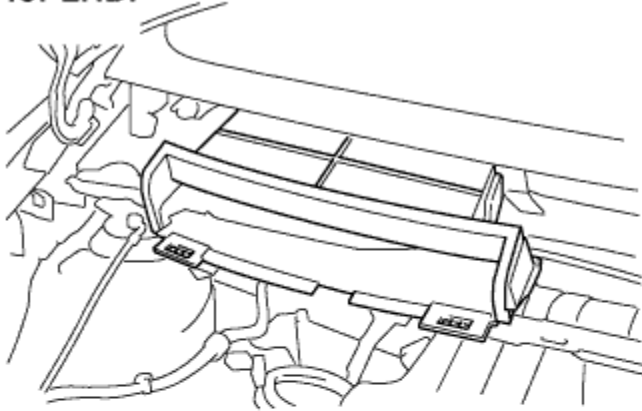

for RHD:

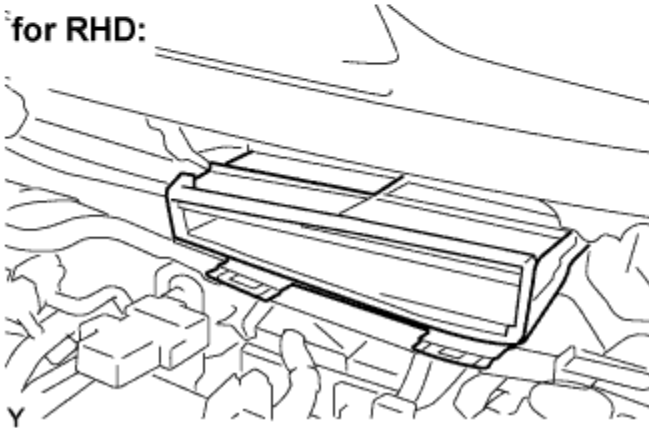

1. Engage the claws, and install the cowl to register duct No. 2.

| |
|---|
| 64. INSTALL FRONT WINDOW WIPER MOTOR AND LINK |
|---|

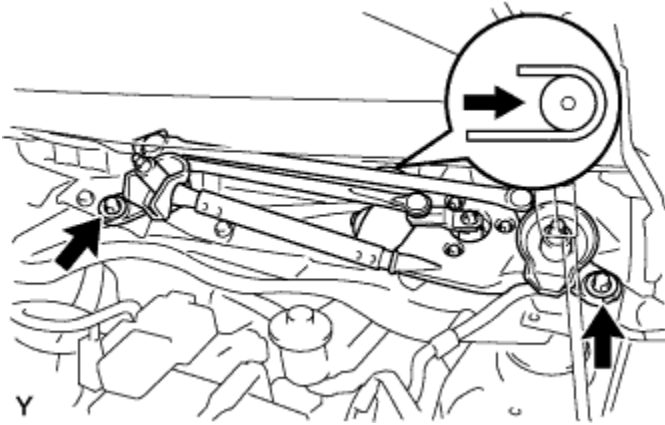

1. Connect the connector.
2. Slide the wiper link as shown in the illustration and engage the rubber pin with the body.
3. Install the front wiper motor and link with the 2 bolts.

Torque:
 5.5 N*m { 56 kgf*cm , 49 in.*lbf }

65. INSTALL COWL TOP VENTILATOR LOUVER LH (for LHD)

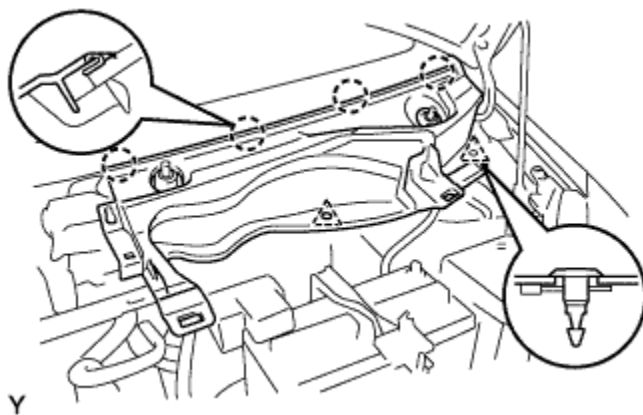

1. Engage the 4 claws and install the cowl top ventilator louver LH.
2. Install the 2 clips.

66. INSTALL COWL TOP VENTILATOR LOUVER SUB-ASSEMBLY (for LHD)

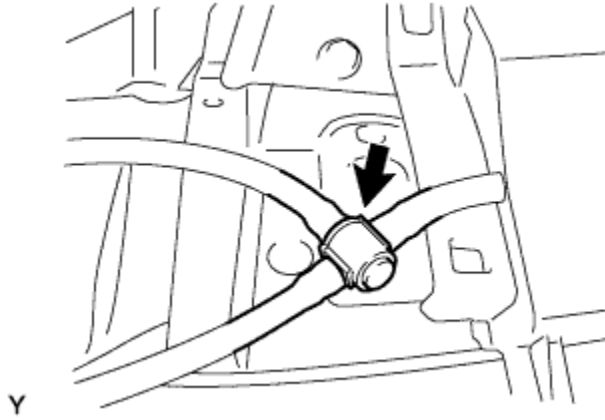

1. Connect the washer hose.

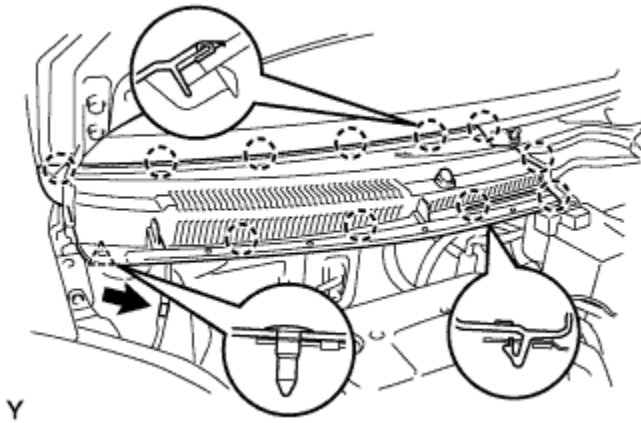

2. Engage the 11 claws and install the cowl top ventilator louver sub-assembly.
3. Install the clip.
4. Connect the washer hose.

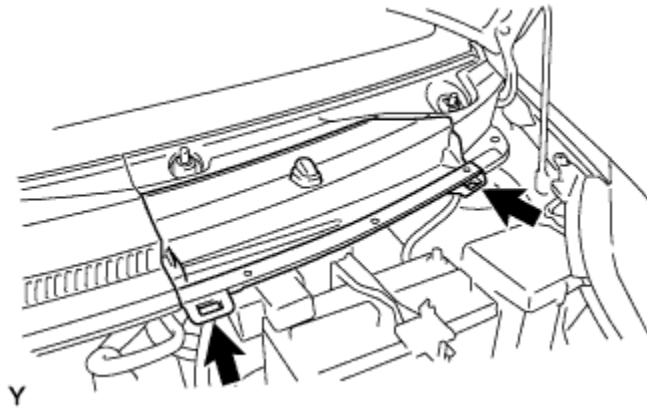

5. Engage the 2 hooks and install cowl top ventilator louver center No. 1.

67. INSTALL COWL TOP VENTILATOR LOUVER LH (for RHD)

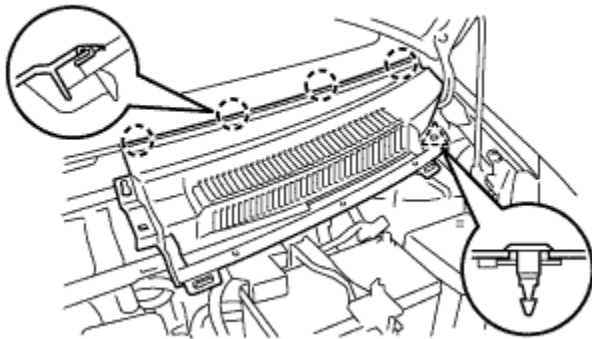

1. Engage the 4 claws and install the cowl top ventilator louver LH.
2. Install the clip.

68. INSTALL COWL TOP VENTILATOR LOUVER SUB-ASSEMBLY (for RHD)

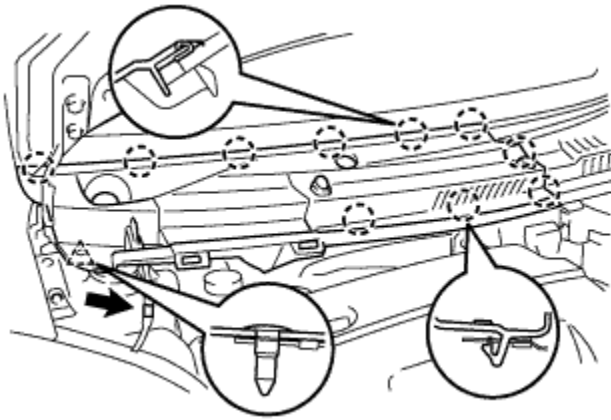

Y

1. Engage the 10 claws and install the cowl top ventilator louver sub-assembly.
2. Install the clip.
3. Connect the washer hose.

69. INSTALL HOOD TO COWL TOP SEAL

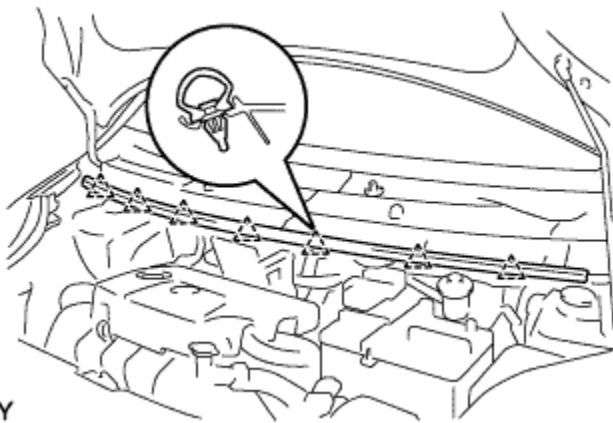

Y

1. Engage the 7 clips and install the hood to cowl top seal.

70. INSTALL FRONT WIPER ARM AND BLADE ASSEMBLY LH

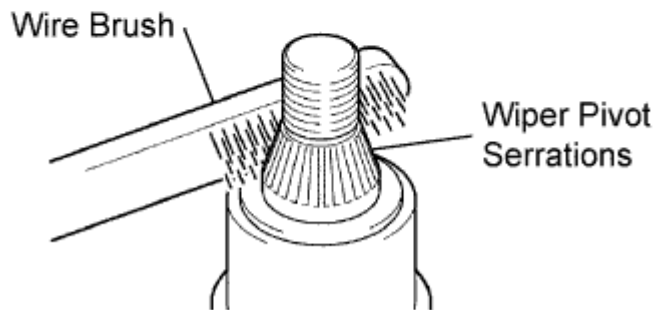
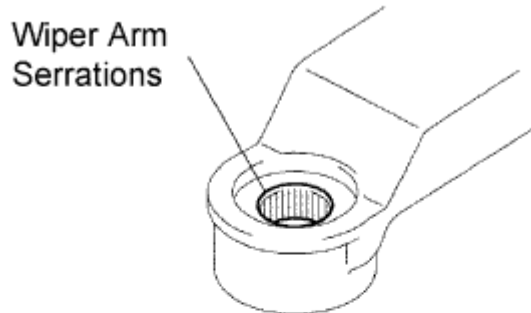

P

1. Scrape any metal powder off the serrated part of the wiper arm with a round file or the equivalent (when reinstalling).
2. Clean the wiper pivot serrations with a wire brush.
3. Operate the wiper, then stop the windshield wiper motor in the automatic stop position.

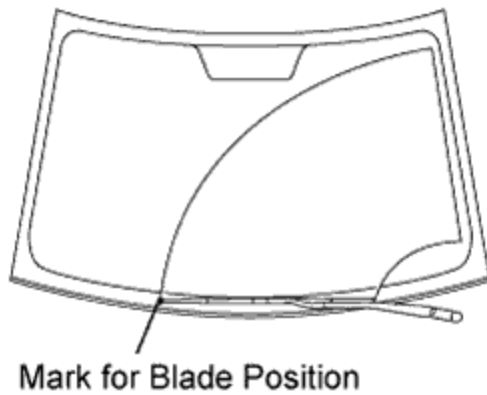

Y

4. Align the blade tip with the mark on the windshield glass, as shown in the illustration.
5. Tighten the nut of the front wiper arm.

Torque:

26 N*m { 265 kgf*cm , 19 ft.*lbf }

71. INSTALL FRONT WIPER ARM AND BLADE ASSEMBLY RH

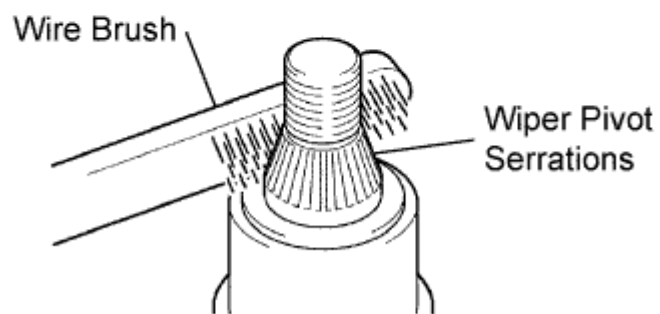
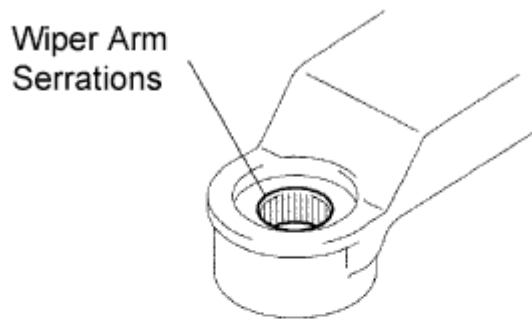

P

1. Scrape any metal powder off the serrated part of the wiper arm with a round file or the equivalent (when reinstalling).
2. Clean the wiper pivot serrations with a wire brush.
3. Operate the wiper, then stop the windshield wiper motor in the automatic stop position.

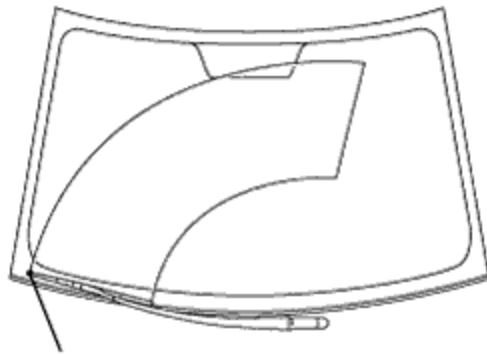

Mark for Blade Position

Y

4. Align the blade tip with the mark on the windshield glass, as shown in the illustration.
5. Tighten the nut of the front wiper arm.

Torque:

26 N*m { 265 kgf*cm , 19 ft.*lbf }

72. INSTALL FRONT WIPER ARM HEAD CAP

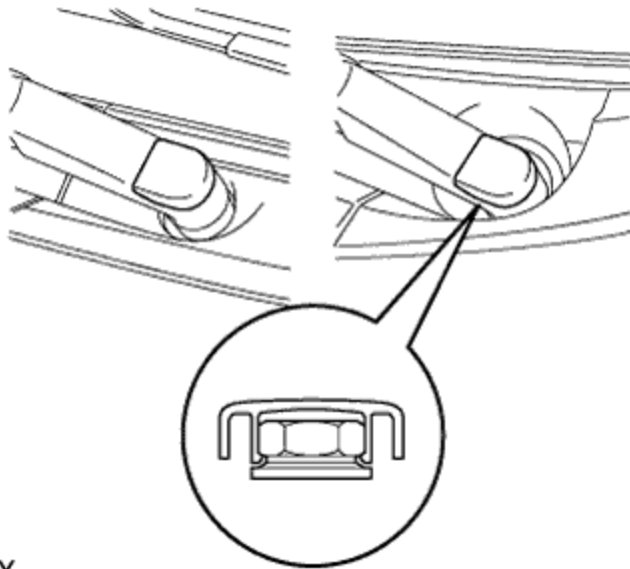

Y

1. Engage the claw and install the 2 front wiper arm head caps.

73. INSTALL FRONT WHEELS

Torque:

103 N*m { 1,050 kgf*cm , 76 ft.*lbf }

74. INSTALL EXHAUST PIPE ASSEMBLY FRONT

1. Using a vernier caliper, measure the free length of the compression spring.

Minimum length:

Front side:

40.5 mm (1.594 in.)

Rear side:

38.5 mm (1.516 in.)

If the free length is less than the minimum, replace the compression spring.

2. Install a new gasket onto the rear side of the exhaust pipe front.

NOTICE:

- Install the gasket in the correct direction.
- Do not reuse the gasket.
- To ensure a proper seal, do not use the tailpipe to force the gasket onto the exhaust pipe front.

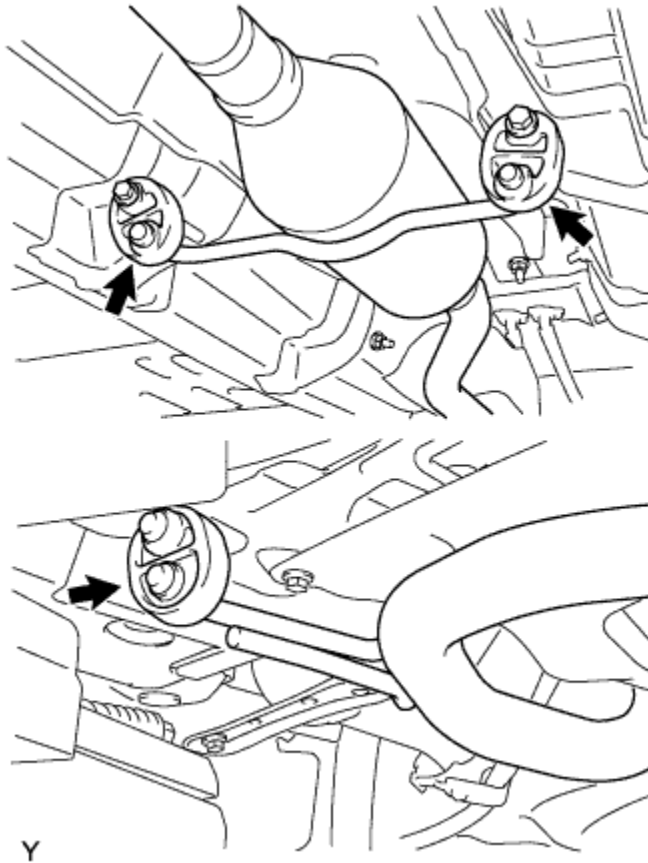

3. Install the 3 supports, and install the exhaust pipe front.



4. Install the exhaust pipe front to the exhaust pipe tail with the 2 bolts and compression springs.

Torque:

43 N*m { 438 kgf*cm , 32 ft.*lbf }

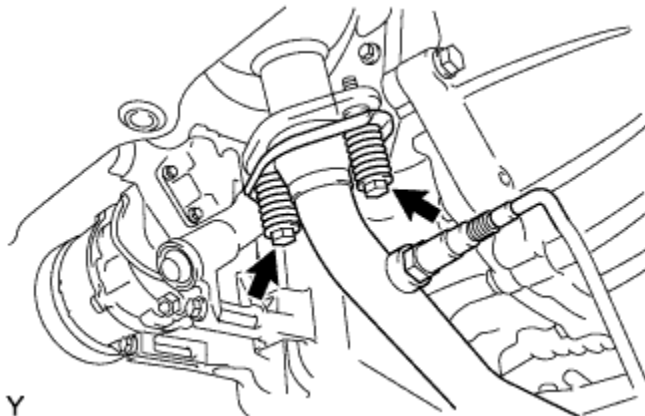

5. Install the exhaust pipe front onto the exhaust manifold with the 2 bolts and compression springs.

Torque:

43 N*m { 438 kgf*cm , 32 ft.*lbf }



6. Connect the oxygen sensor connector, and engage the 3 wire harness clamps.

75. INSTALL EGR INLET EXHAUST MANIFOLD PLATE

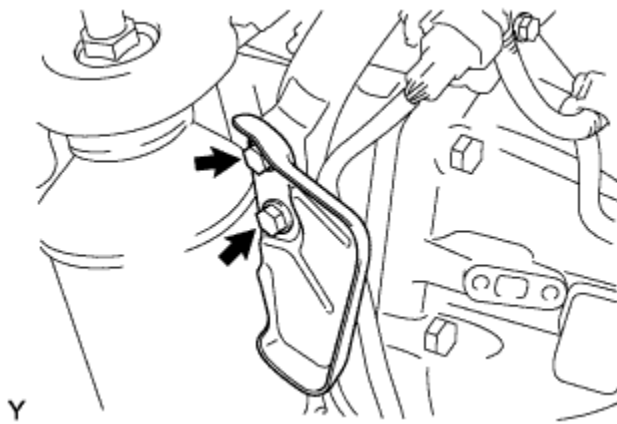

1. Install the EGR inlet exhaust manifold plate with the 2 bolts.

Torque:
18 N*m { 184 kgf*cm , 13 ft.*lbf }

76. INSTALL BATTERY CARRIER

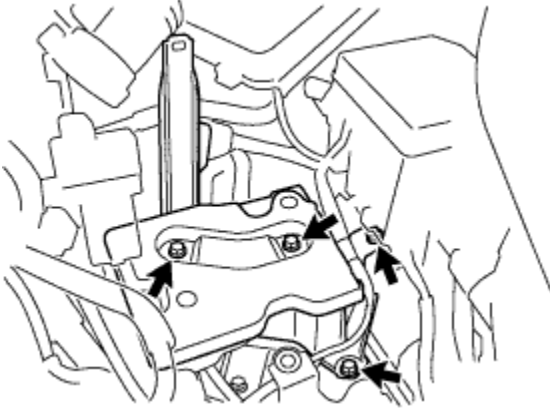

1. Install the battery carrier with the 4 bolts.

Torque:
17 N*m { 174 kgf*cm , 13 ft.*lbf }

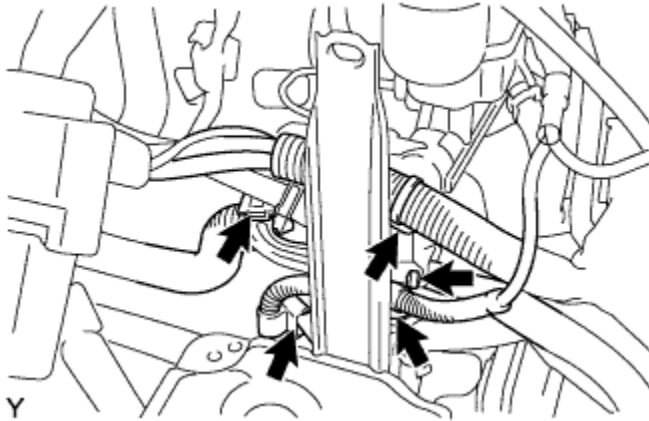

2. Engage the 5 clamps, and install the engine wire harness.

77. INSTALL BATTERY TRAY

78. INSTALL BATTERY

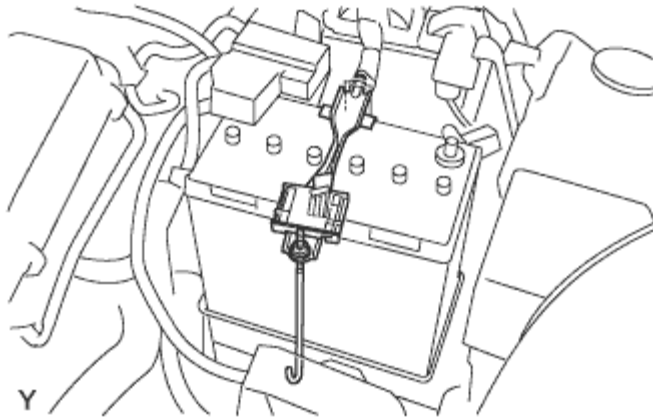

1. Install the battery onto the battery tray.
2. Install the battery carrier clamp with the nut.
3. Install the positive and negative terminals.

Torque:

5.4 N*m { 55 kgf*cm , 48 in.*lbf }

79. ADD ENGINE COOLANT

1. Tighten all the plugs.
2. Disconnect the vinyl hose.
3. Pour engine coolant into the radiator assembly until it overflows.

Capacity:

4.5 liters (4.8 USqts, 4.2 Imp. qts)

NOTICE:

Do not substitute water for engine coolant.

HINT:

- Use of improper engine coolant may damage the engine coolant system.
- Use only Toyota Super Long Life Coolant or similar high quality ethylene glycol based non-silicate, non-amine, non-nitrite, and non-borate engine coolant with long-life hybrid organic acid technology (coolant with long-life hybrid organic acid technology consists of a combination of low phosphates and organic acids).

4. Check the engine coolant level inside the radiator assembly by squeezing the inlet and outlet radiator hoses several times by hand. If the engine coolant level goes down, add engine coolant.
5. Install the radiator cap sub-assembly securely.
6. Slowly pour engine coolant into the radiator reservoir until it reaches the FULL line.
7. Warm up the engine until the cooling fan operates.
 1. Set the air conditioning as follows while warming up the engine.

| Item | Manual air conditioning system | Automatic air conditioning system |
|------------------------|--|--|
| Set control as follows | Fan speed - Any setting except "OFF" Temperature - Toward WARM Air conditioning switch "OFF" | Fan speed - Any setting except "OFF" Temperature - To the highest temperature Air conditioning switch "OFF" "AUTO" switch "OFF" |

2. Maintain the engine speed at 2,000 to 2,500 rpm and warm up the engine until the cooling fan operates.
8. Stop the engine and wait until the coolant cools down.
9. If the engine coolant level is below the full level, perform steps (c) through (h) again and repeat the operation until the engine coolant level stays at the full level.
10. Recheck the engine coolant level inside the radiator reservoir tank assembly. If it is below the full level, add engine coolant.

80. ADD MANUAL TRANSAXLE OIL

81. INSPECT MANUAL TRANSAXLE OIL

1. Stop the vehicle in a level place.

- Remove the transmission filler plug and the gasket.

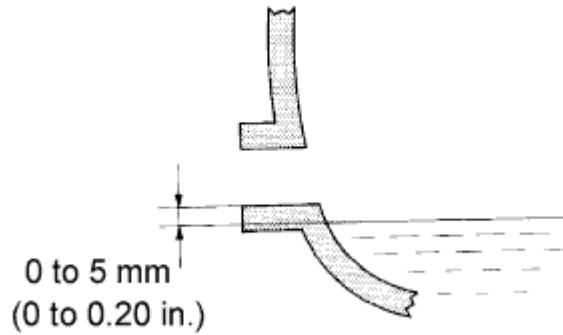

- Check that the oil surface is within 5 mm (0.20 in.) of the bottom of the transmission filler plug opening.

NOTICE:

- Excessively large or small amounts of oil may cause problems.
 - After replacing the oil, drive the vehicle and check the oil level again.
- Check for oil leakage if the oil level is low.
 - Install the transmission filler plug and a new gasket.

Torque:

39 N*m { 400 kgf*cm , 29 ft.*lbf }

82. ADD ENGINE OIL

- Fill with new engine oil.

Oil capacity:

| Item | Specification |
|---------------------------|--------------------------------------|
| With oil filter change | 3.1 liter (3.3 Us qts, 2.7 Imp. qts) |
| Without oil filter change | 2.9 liter (3.1 Us qts, 2.6 Imp. qts) |

| | |
|----------|---|
| Dry fill | 3.4 liter (3.6 Us qts, 3.0 Imp. qts) |
|----------|---|

83. CHECK FOR ENGINE COOLANT LEAKAGE

CAUTION:

To avoid the danger of being burned, do not remove the radiator cap sub-assembly while the engine and radiator assembly are still hot. Thermal expansion will cause hot engine coolant and steam to blow out from the radiator assembly.

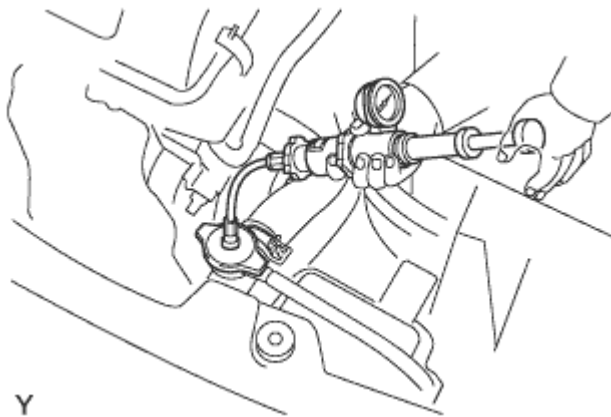

1. Fill the radiator assembly with engine coolant, then attach a radiator cap tester.
2. Pump it to 137 kPa (1.4 kgf/cm², 19.9 psi), then check that the pressure does not drop.
If the pressure drops, check the hoses, radiator assembly and water pump assembly for leakage. If there are no signs or traces of external engine coolant leakage, check the heater core, cylinder block and head.

84. CHECK FOR MANUAL TRANSAXLE OIL LEAKAGE

85. CHECK FOR ENGINE OIL LEAKAGE

86. CHECK FOR EXHAUST GAS LEAKAGE

87. INSPECT IGNITION TIMING

NOTICE:

- Turn all the electrical systems and the A/C off.
 - Inspect the ignition timing with the cooling fan off.
 - When checking the ignition timing, shift the transmission to the neutral position.
1. Warm up and stop the engine.

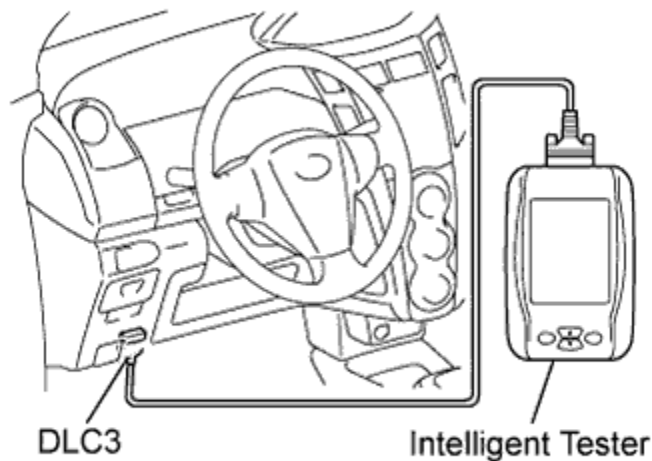

2. When using the intelligent tester:
 1. Connect the intelligent tester to the DLC3.
 2. Turn the Ignition Switch on (IG).
 3. Select the following menu items:
Powertrain / Engine and ECT / Active Test / TE1 (TC) / ON.

HINT:

Refer to the intelligent tester operator's manual for further information regarding the selection of Active Test.

4. Inspect the ignition timing during idling.

Ignition timing:

8 to 12° BTDC

5. Select the following menu items:
TE1 (TC) / OFF
6. Turn the Ignition Switch off.
7. Disconnect the intelligent tester from the DLC3.

3. When not using the intelligent tester:

1. Remove the air cleaner cap sub-assembly ().

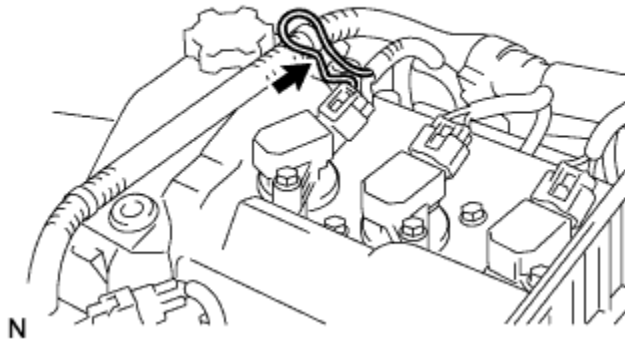

2. Install the tester terminal of a timing light onto the position shown in the illustration.

NOTICE:

- Use a timing light that detects the first signal.
- Wrap the wire harness with tape after checking.

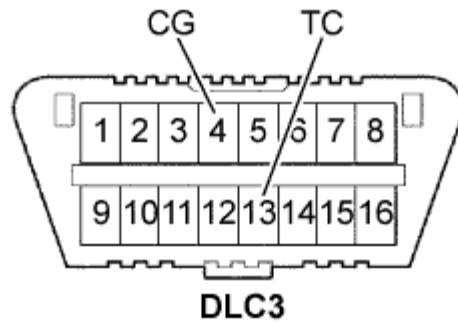

- Using SST, connect terminals 13 (TC) and 4 (CG) of the DLC3.

SST

09843-18040

NOTICE:

Check the terminal numbers before connecting them. Connecting the wrong terminals could damage the engine.

- Turn the Ignition Switch on (IG).
- Inspect the ignition timing during idling.

Ignition timing:

0 to 15° BTDC

HINT:

Run the engine speed at 1,000 to 1,300 rpm for 5 seconds, then check that the engine speed returns to the idling speed.

- Disconnect terminals 13 (TC) and 4 (CG) of the DCL3.
- Turn the Ignition Switch off.
- Remove the timing light.
- Install the air cleaner cap sub-assembly ().

88. INSPECT ENGINE IDLING SPEED

NOTICE:

- Turn all the electrical systems and the A/C off.
- Inspect the engine idling speed with the cooling fan off.
- When checking the idling speed, shift the transmission to the neutral position.

- Warm up and stop the engine.

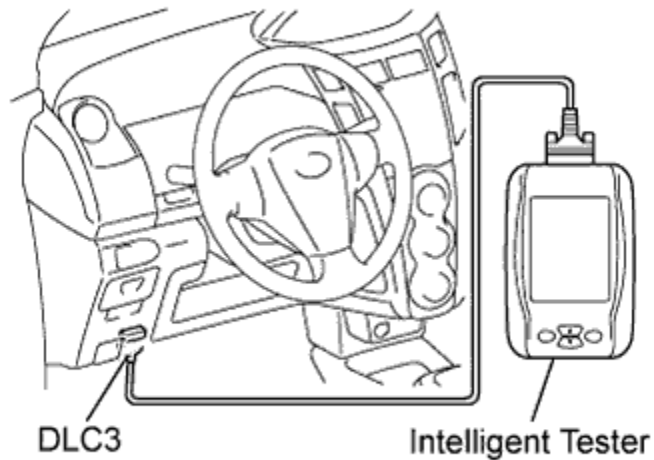

2. When using the intelligent tester:

1. Connect the intelligent tester to the DLC3.
2. Turn the Ignition Switch on (IG).
3. Select the following menu items:
Powertrain / Engine and ECT / Data List / Engine SPD.

HINT:

Refer to the intelligent tester operator's manual for further information regarding the selection of Data List.

4. Inspect the engine idling speed.

Idling speed:

730 to 830 rpm

5. Turn the Ignition Switch off.
6. Disconnect the intelligent tester from the DCL3.

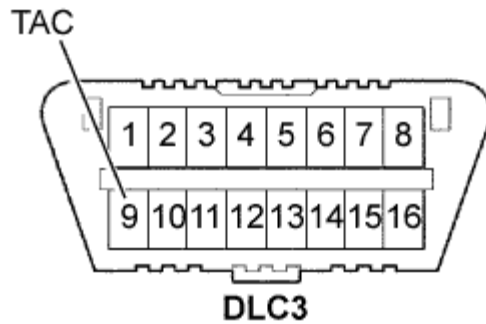

3. When not using an intelligent tester:

1. Install SST to terminal 9 (TAC) of the DLC3, then connect a tachometer.

SST
09843-18040

NOTICE:

Check the terminal numbers before connecting them. Connecting the wrong terminals could damage the engine.

2. Turn the Ignition Switch on (IG).
3. Inspect the engine idling speed.

Idling speed:
730 to 830 rpm

4. Turn the Ignition Switch off.
5. Disconnect the tachometer.
6. Remove SST from terminal 9 (TAC).

89. INSPECT CO/HC

HINT:

The ECM controls the concentration of CO/HC in the emission gas.

1. Start the engine.
2. Run the engine at 2,500 rpm for approximately 180 seconds.
3. Insert the CO/HC meter testing probe at least 40 cm (1.3 ft) into the tailpipe during idling.

4. Check the CO/HC concentration during idling and when running at 2,500 rpm.

Standard:

CO concentration:

0.2 % or less

HC concentration:

70 ppm or less

If the CO/HC concentration does not comply with the regulations, troubleshoot in the order given below.

- Check the heated oxygen sensor operation (and/or).
- See the table below for possible causes, then inspect the applicable parts and repair them if necessary.

| CO | HC | Problems | Causes |
|--------|------|--|---|
| Normal | High | Rough idling | 3. Faulty ignition: <ul style="list-style-type: none"> • Fouled, shorted or improperly gapped plugs 4. Incorrect valve clearance 5. Leakage from intake and exhaust valves 6. Leakage from cylinders |
| Low | High | Rough idling (Fluctuating HC reading) | 7. Lean mixture causing misfire 8. Faulty SFI systems: <ul style="list-style-type: none"> • Faulty pressure regulator • Faulty engine coolant temperature sensor • Faulty mass air flow meter • Faulty ECM • Faulty injectors • Faulty throttle body |
| High | High | Rough idling (Black smoke from exhaust) | 9. Faulty SFI systems: <ul style="list-style-type: none"> • Faulty pressure regulator • Faulty engine coolant temperature sensor • Faulty mass air flow meter • Faulty ECM |

| | | | |
|--|--|--|---|
| | | | <ul style="list-style-type: none">• Faulty injectors• Faulty throttle body |
|--|--|--|---|

90. INSPECT AND ADJUST FRONT WHEEL ALIGNMENT

()

91. INSTALL ENGINE UNDER COVER RH

92. INSTALL ENGINE UNDER COVER LH

93. INSTALL FRONT SPOILER COVER (w/ Front Spoiler Cover)

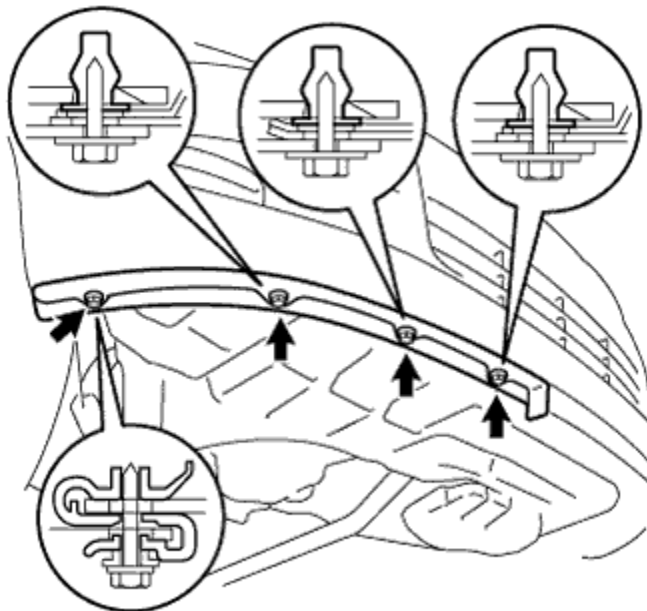

T

1. Install the front spoiler cover with the 4 screws.

94. INSTALL FRONT SPOILER COVER LH (w/ Front Spoiler Cover LH)

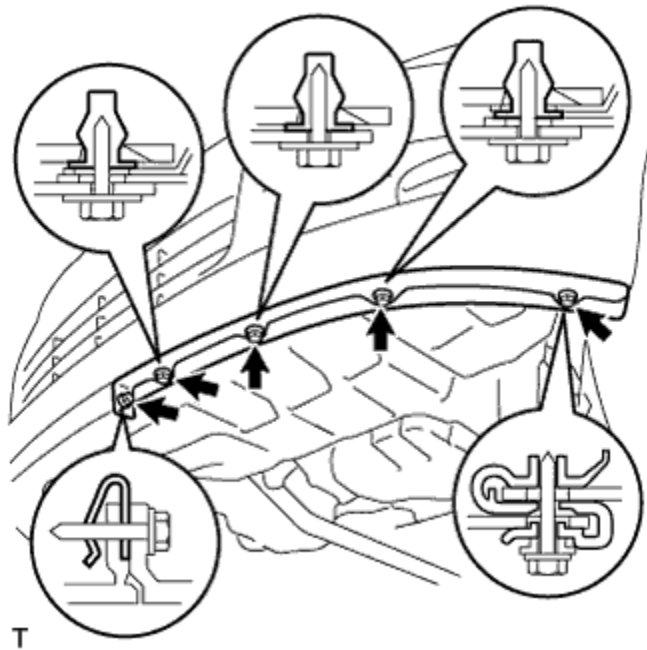

1. Install the front spoiler cover with the 5 screws.

ENGINE ASSEMBLY > INSTALLATION

1. INSTALL RADIATOR HOSE NO. 1

2. INSTALL RADIATOR HOSE NO. 2

3. INSTALL HEATER WATER OUTLET HOSE A (FROM HEATER UNIT)

4. INSTALL HEATER WATER INLET HOSE A

5. INSTALL ENGINE WIRE

6. INSTALL KNOCK SENSOR

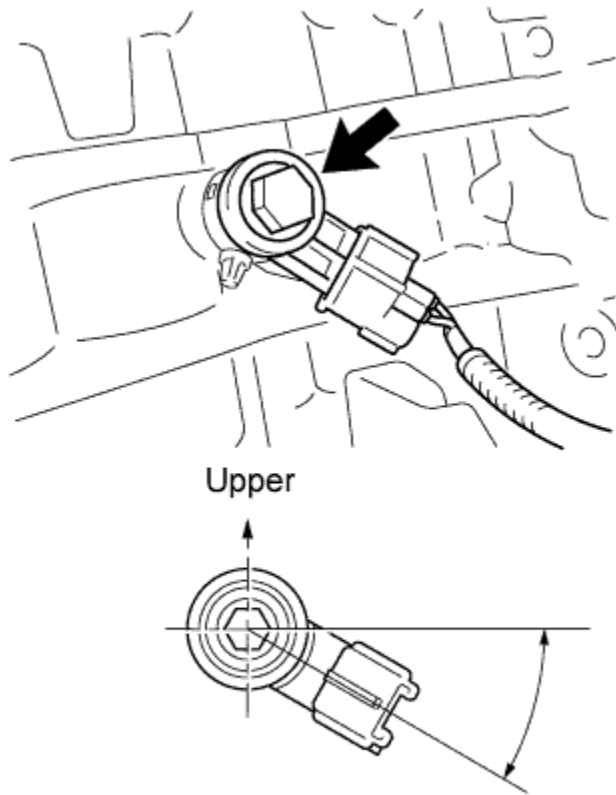

Y

1. Install the knock sensor with the bolt.

Torque:

20 N*m { 204 kgf*cm , 15 ft.*lbf }

HINT:

It is acceptable for the sensor to be tilted 0 to 45°.

2. Connect the connector.

7. INSTALL RADIO SETTING CONDENSER

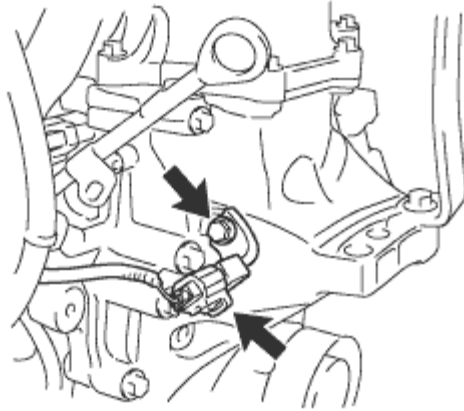

Y

1. Install the condenser with the bolt.

Torque:
10 N*m { 102 kgf*cm , 7 ft.*lbf }

2. Connect the connector.

8. INSTALL FUEL INJECTOR ASSEMBLY

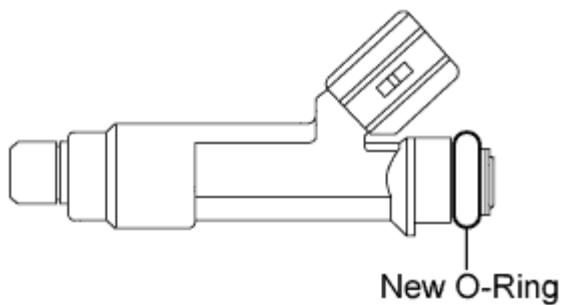

Y

1. Apply a light coat of grease or gasoline to a new O-ring, and install it onto the injector.
2. Apply a light coat of grease or gasoline to the place where the delivery pipe touches the O-ring.

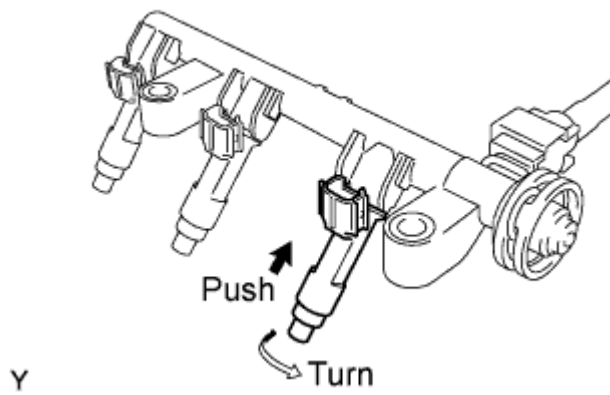

3. Push the fuel injector while twisting it back and forth to install it in the fuel delivery pipe.

NOTICE:

- Do not twist the O-ring.
- Check that the fuel injector turns smoothly after installing it. If it does not, reinstall it with a new O-ring.

4. Position the injector connectors so that they face upward.

9. INSTALL FUEL DELIVERY PIPE

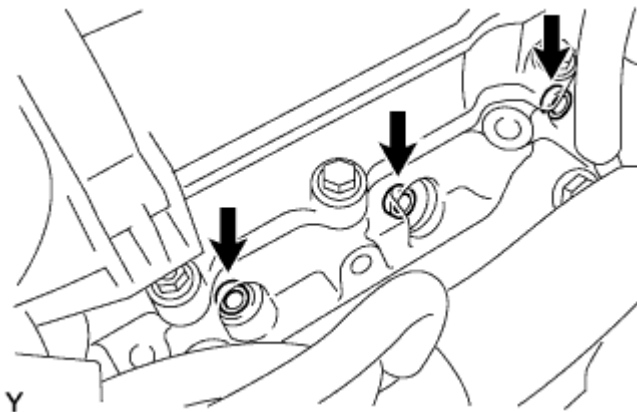

1. Install 3 new fuel injector vibration insulators to the cylinder head.

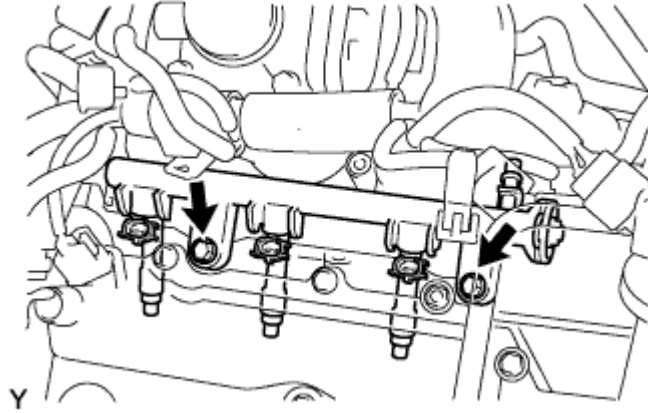

2. Place the fuel delivery pipe and the 3 fuel injectors together to the cylinder head.

NOTICE:

Do not drop the fuel injectors when installing the fuel delivery pipe .

3. Provisionally install the 2 bolts which are used to hold the fuel delivery pipe to the cylinder head.

NOTICE:

Check that the fuel injector turns smoothly after installing it. If does not, reinstall it with a new O-ring.

4. Tighten the 2 bolts which are used to hold the fuel delivery pipe to the cylinder head.

Torque:

27 N*m { 275 kgf*cm , 20 ft.*lbf }

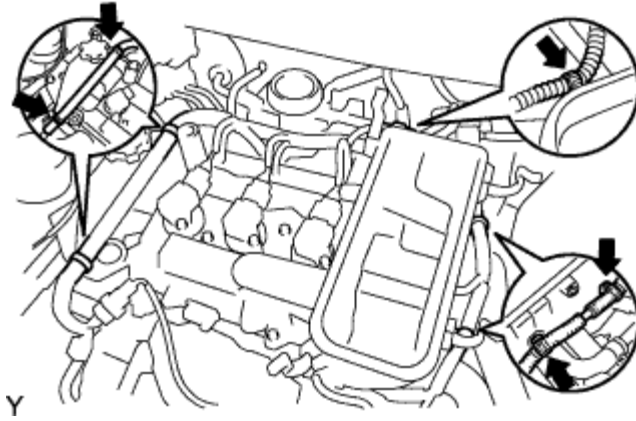

5. Engage the 5 clamps and install the engine wire harness onto the cylinder head cover.

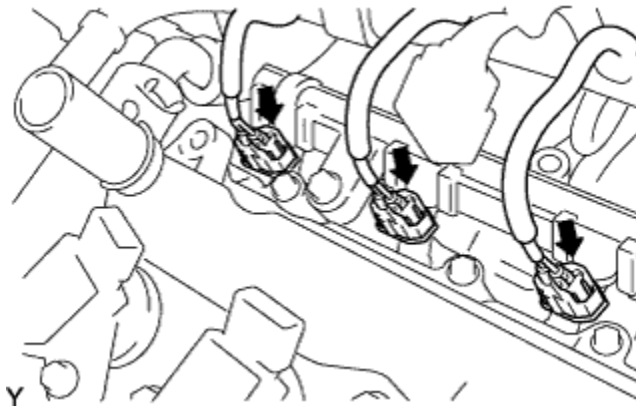

6. Connect the 3 injector connectors.

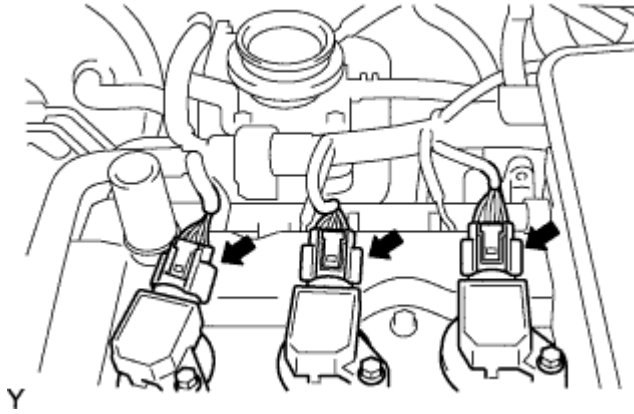

7. Connect the 3 ignition coil connectors.

10. INSTALL INTAKE MANIFOLD

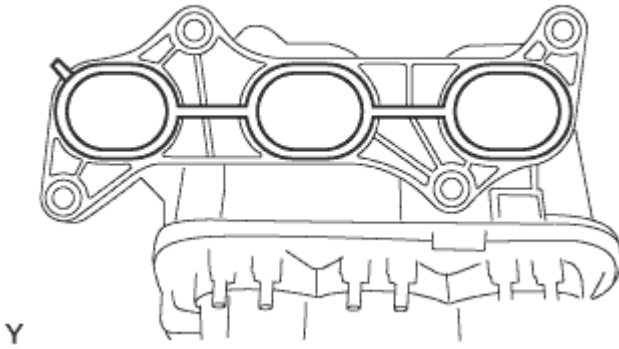

1. Install a new gasket.

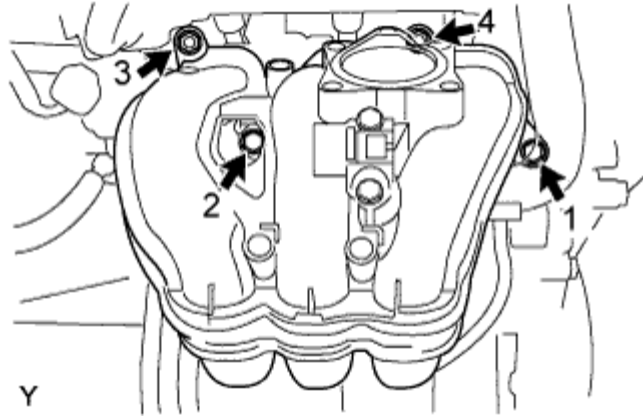

2. Install the intake manifold with the 2 bolts and 2 nuts in the order shown in the illustration.

Torque:
30 N*m { 306 kgf*cm , 22 ft.*lbf }

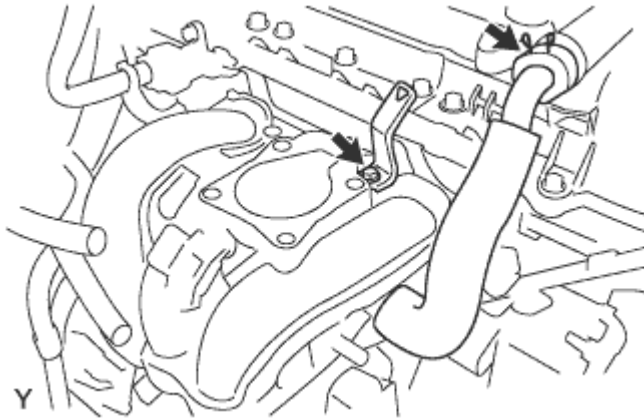

3. Install the wire harness clamp with the bolt.

Torque:
8.4 N*m { 85 kgf*cm , 74 in.*lbf }

4. Connect the ventilation hose.

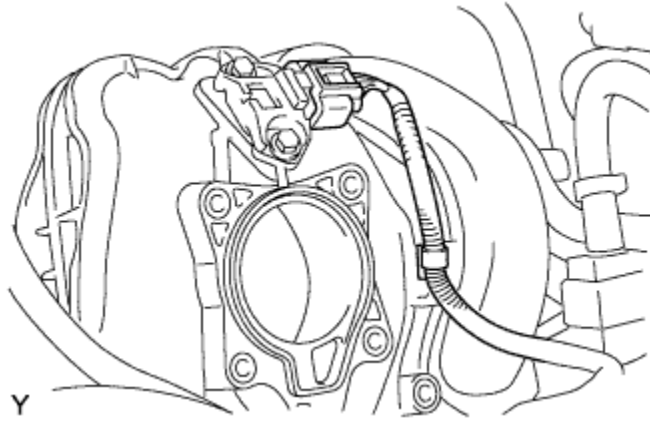

5. Connect the manifold absolute pressure sensor connector and the wire harness clamp.

11. INSTALL INTAKE MANIFOLD STAY



1. Install the intake manifold stay with the 2 bolts.

Torque:
21 N*m { 214 kgf*cm , 16 ft.*lbf }

12. INSTALL THROTTLE WITH MOTOR BODY ASSEMBLY

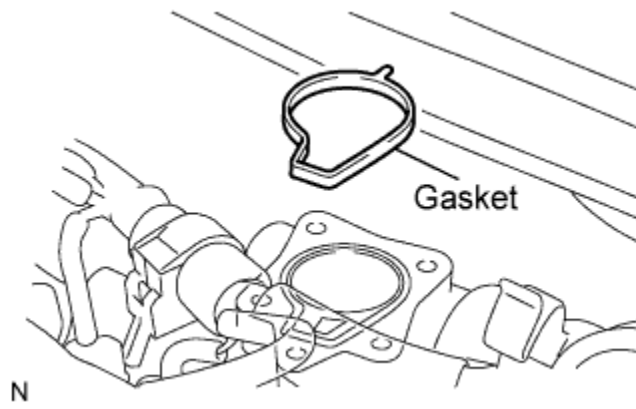

1. Install a new throttle body gasket.

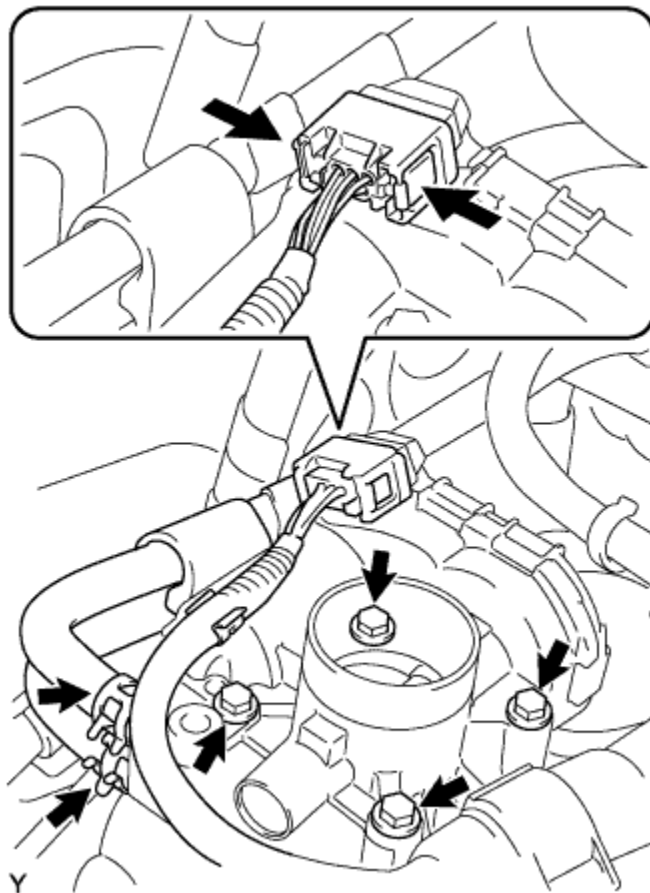

2. Install the throttle body with the 4 bolts.

Torque:

10 N*m { 102 kgf*cm , 7.4 ft.*lbf }

NOTICE:

Do not bend the throttle body gasket while installing the throttle body.

3. Connect the 2 water by-pass hoses.
4. Connect the connector and the wire harness clamp.

13. INSTALL EXHAUST MANIFOLD ASSEMBLY

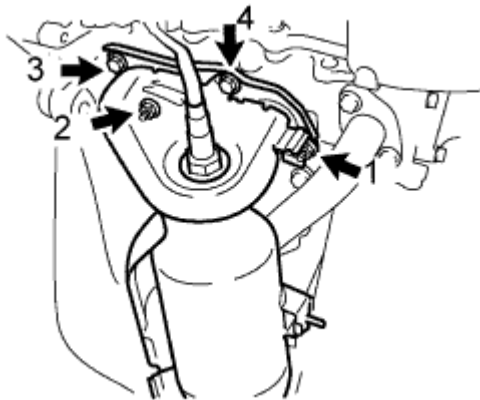

1. Install a new gasket.
2. Install the exhaust manifold with the 2 bolts and 2 nuts in the order shown in the illustration.

Torque:

24 N*m { 245 kgf*cm , 18 ft.*lbf }

14. INSTALL MANIFOLD STAY

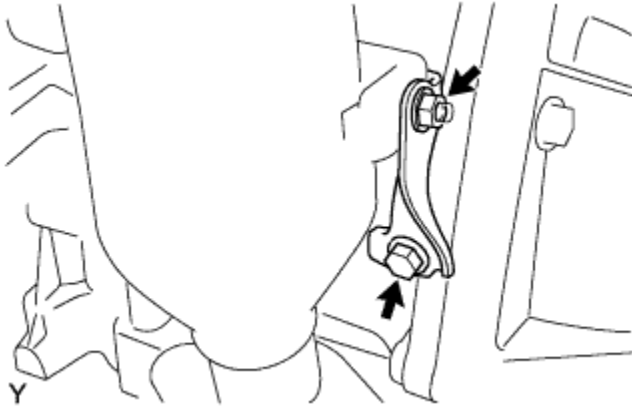

1. Install the manifold stay with the bolt and nut.

Torque:

24 N*m { 245 kgf*cm , 18 ft.*lbf }

15. INSTALL DUTY VACUUM SWITCHING VALVE

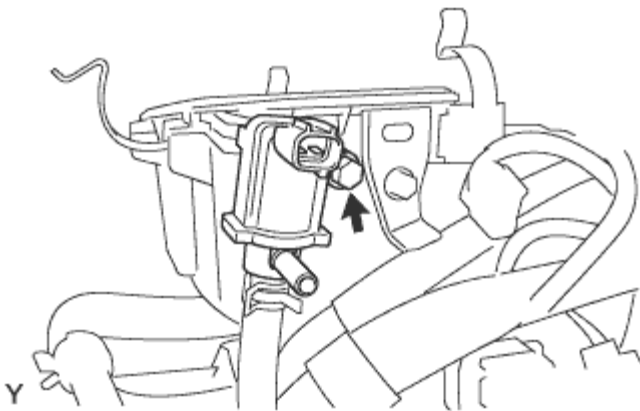

1. Install the duty vacuum switching valve with the bolt.

Torque:

8.8 N*m { 90 kgf*cm , 78 in.*lbf }

2. Connect the connector.

16. INSTALL IGNITION COIL NO. 1

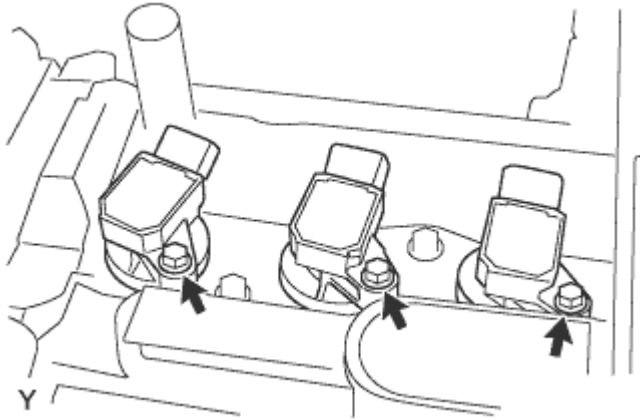

1. Install the ignition coil with the 3 bolts.

Torque:
9.2 N*m { 94 kgf*cm , 81 in.*lbf }

2. Connect the 3 connectors.

17. INSTALL FLYWHEEL ASSEMBLY

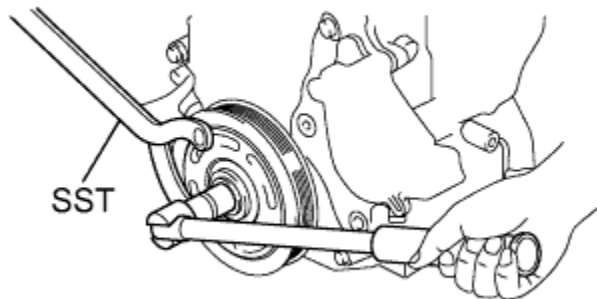

1. Hold the crankshaft with SST.

SST
09960-10010 (09962-01000, 09963-01000)

2. Clean the 6 bolts and their holes.

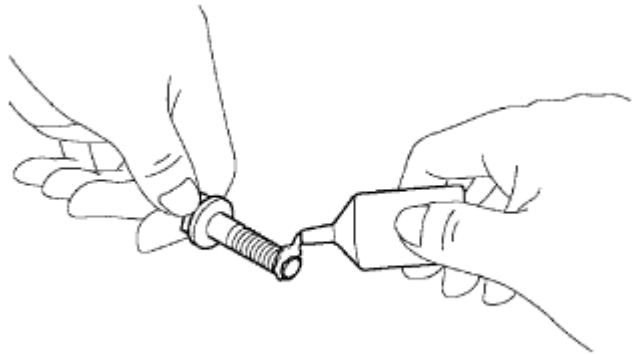

Y

A57108

3. Apply adhesive to the end 2 or 3 threads of the bolts.

Adhesive:
Part No. 08833-00070, THREE BOND 1324 or the equivalent

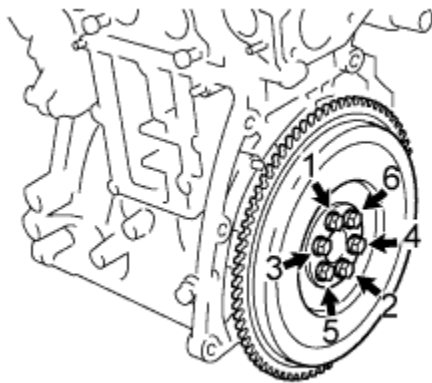

N

4. Install the flywheel with the 6 bolts in the order shown in the illustration.

Torque:
78 N*m { 796 kgf*cm , 58 ft.*lbf }

18. INSTALL CLUTCH COVER ASSEMBLY (for Multi-Mode Manual Transaxle)

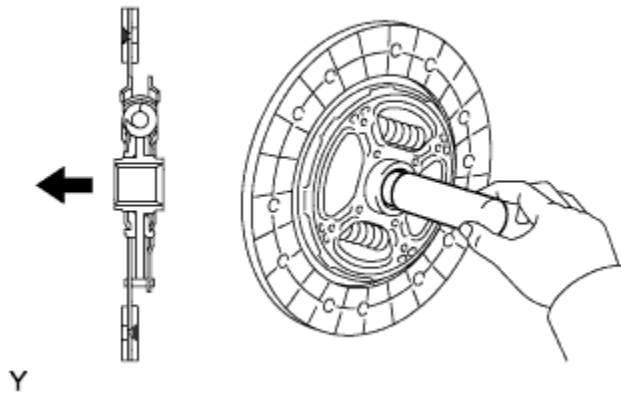

1. Insert SST into the clutch disc, then insert them into the flywheel.

SST
09301-00131

HINT:
Insert the clutch disc in the correct orientation.

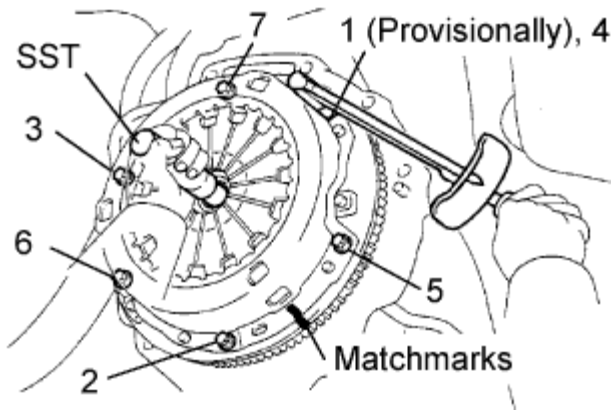

2. Align the matchmarks on the clutch cover and flywheel.
3. Following the procedures shown in the illustration, tighten the 6 bolts in the order starting with the bolt located near the knock pin on the top.

Torque:
19 N*m { 195 kgf*cm , 14 ft.*lbf }
HINT:

- Following the order in the illustration, uniformly tighten the bolts.
- Move SST up and down, right and left gently after checking that the disc is in the center and tighten the bolts.

19. INSTALL CLUTCH DISC ASSEMBLY (for Manual Transaxle)

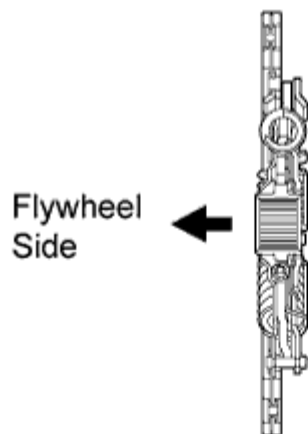
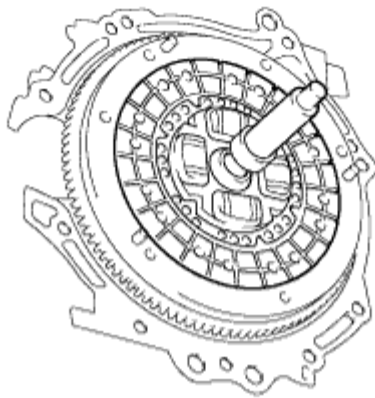

P

1. Insert SST into the clutch disc, and then insert them into the flywheel.

SST
09301-00210
NOTICE:

Insert the clutch disc in the correct direction.

20. INSTALL CLUTCH COVER ASSEMBLY (for Manual Transaxle)

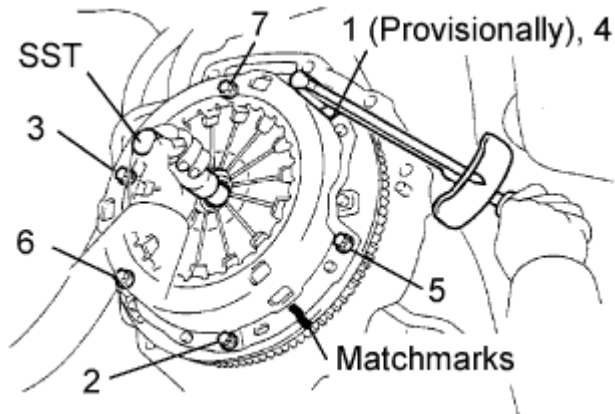

1. Align the matchmark on the clutch cover with the one on the flywheel.
2. Tighten the 6 bolts uniformly in the order shown in the illustration, starting with the bolt located near the knock pin at the top.

Torque:

19 N*m { 195 kgf*cm , 14 ft.*lbf }

HINT:

After checking that the disc is in the center, gently move SST up and down, right and left to tighten the bolts.

SST

09301-00210

21. INSTALL MULTI-MODE MANUAL TRANSAXLE (for Multi-Mode Manual Transaxle)

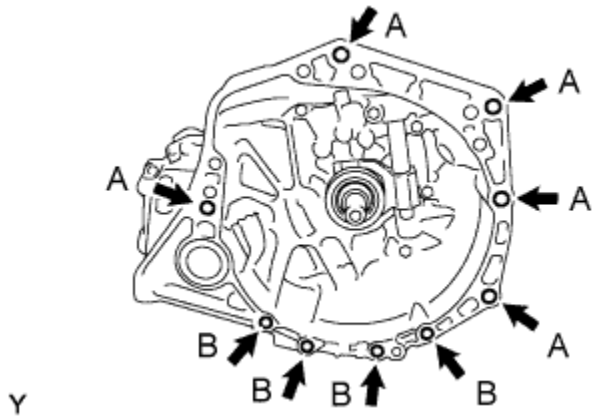

1. Align the input shaft with the clutch disc and install the multi-mode manual transaxle onto the engine.
2. Install the 9 bolts.

Torque:

Bolt A:

64 N*m { 653 kgf*cm , 47 ft.*lbf }

Bolt B:

39 N*m { 398 kgf*cm , 29 ft.*lbf }

NOTICE:

- Insert a dowel pin securely into the dowel hose so that the end face of the transaxle assembly is in close contact with the engine assembly before tightening the bolts to fix the engine and transaxle.
- Make sure that the dowel pins are not loose, bent, damaged or scratched and then install the transaxle onto the engine with the contact surfaces of the engine and transaxle flat against each other.

| |
|--|
| 22. INSTALL MANUAL TRANSAXLE ASSEMBLY (for Manual Transaxle) |
|--|

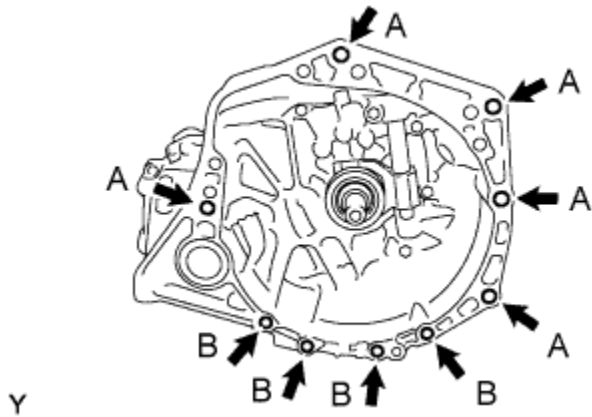

1. Align the input shaft with the clutch disc and install the manual transaxle onto the engine.
2. Install the 9 bolts.

Torque:

Bolt A:

64 N*m { 653 kgf*cm , 47 ft.*lbf }

Bolt B:

39 N*m { 398 kgf*cm , 29 ft.*lbf }

NOTICE:

Insert a dowel pin securely into the dowel hole so that the end face of the transaxle assembly is in close contact with the engine assembly before tightening the bolts to fix the engine and transaxle.

23. INSTALL ENGINE MOVING CONTROL ROD

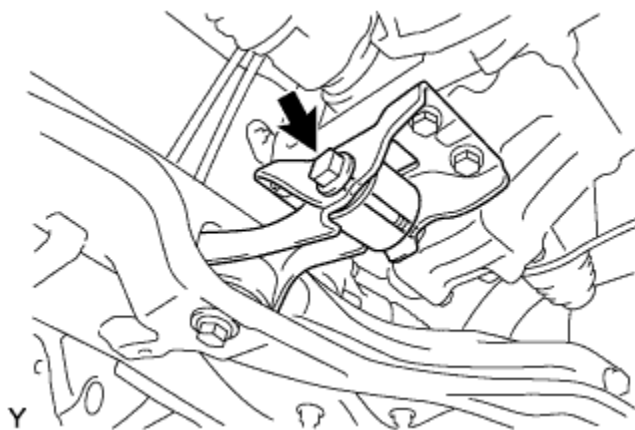

1. Install the engine moving control rod with the bolt.

Torque:

120 N*m { 1,224 kgf*cm , 89 ft.*lbf }

24. INSTALL STARTER ASSEMBLY (for 0.8 kW Type)

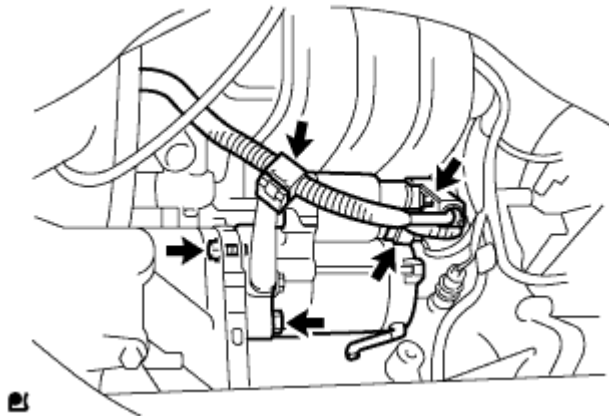

1. Install the starter assembly with the 2 bolts.

Torque:

37 N*m { 377 kgf*cm , 27 ft.*lbf }

2. Connect the connector.
3. Connect terminal 30 with the nut.

Torque:

9.8 N*m { 100 kgf*cm , 7.2 ft.*lbf }

4. Close the terminal cap.

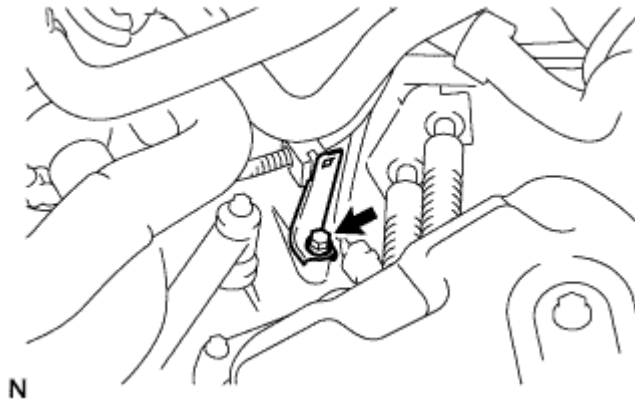

5. Install the wire harness bracket with the bolt.

Torque:
 8 N*m { 82 kgf*cm , 71 in.*lbf }

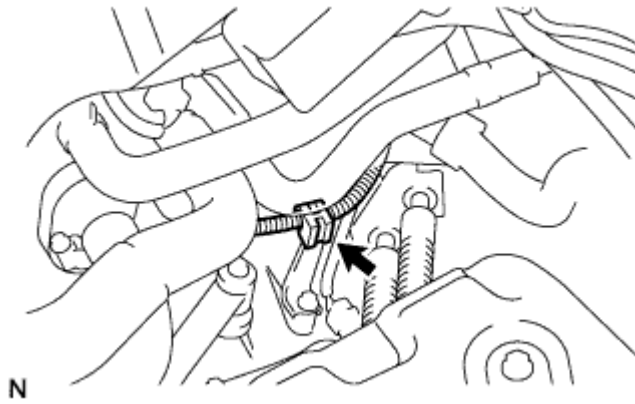

6. Install the harness clamp.

| | |
|--|----------|
| 25. INSTALL STARTER ASSEMBLY (for 0.9 kW Type) | |
| Transaxle Type | See Page |
| C551 | |
| C551A | |

26. INSTALL STARTER ASSEMBLY (for 1.0 kW Type)

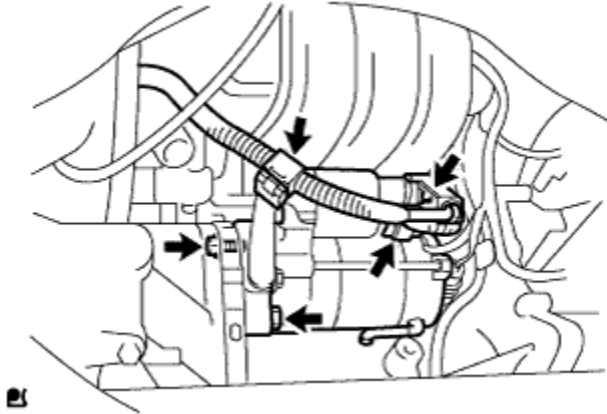

1. Install the starter assembly with the 2 bolts.

Torque:
37 N*m { 377 kgf*cm , 27 ft.*lbf }

2. Connect the connector.
3. Connect terminal 30 with the nut.

Torque:
9.8 N*m { 100 kgf*cm , 7.2 ft.*lbf }

4. Close the terminal cap.

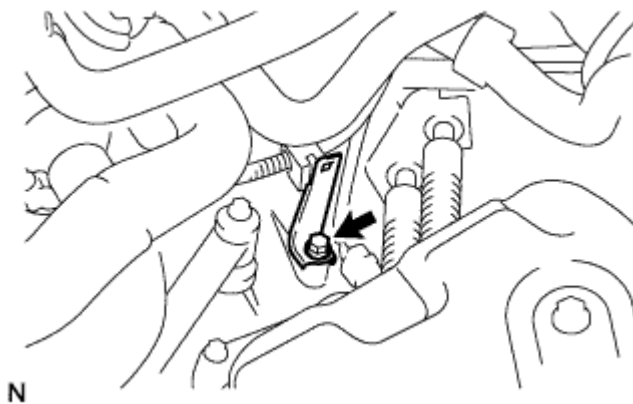

5. Install the wire harness bracket with the bolt.

Torque:

8 N*m { 82 kgf*cm , 71 ft.*lbf }

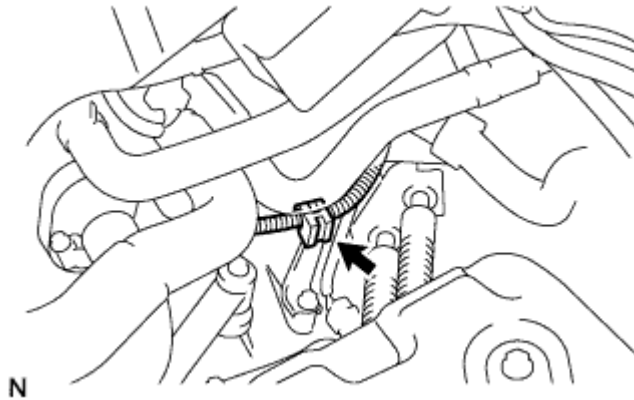

6. Install the harness clamp.

| | |
|--|--|
| 27. INSTALL STARTER ASSEMBLY (for 1.3 kW Type) | |
|--|--|

| Transaxle Type | See Page |
|----------------|----------|
| C551 | |
| C551A | |

| |
|---|
| 28. INSTALL FLYWHEEL HOUSING SIDE COVER (for 0.8 kW Type) |
|---|

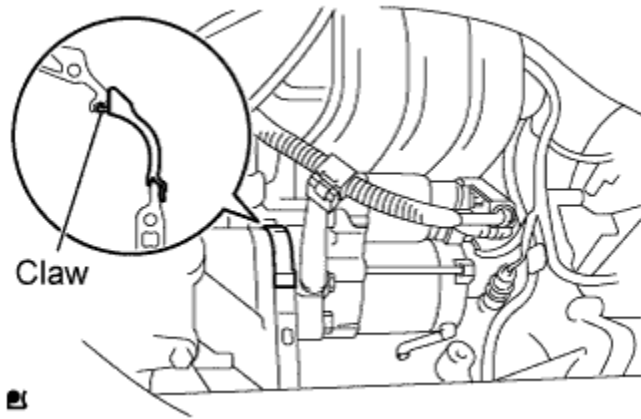

1. Insert the protruding portion into the end of the cylinder block and while pushing it along the cylinder block, fit the claw into the cylinder block.

NOTICE:

- Make sure that the claw makes a click sound, indicating that it fits tightly.
- Replace the claw with a new one if it does not fit tightly or is deformed.

29. INSTALL FLYWHEEL HOUSING SIDE COVER (for 0.9 kW Type)

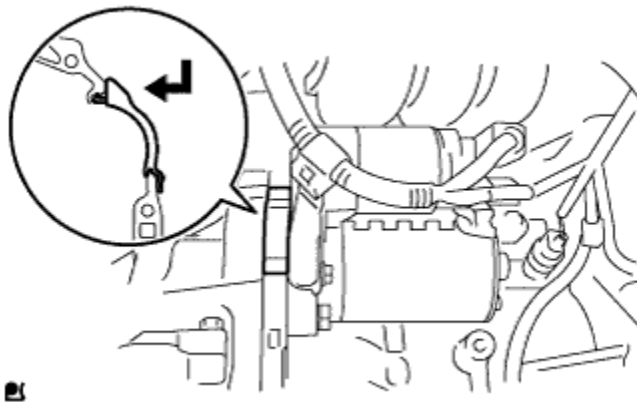

1. Insert the protruding portion into the end of the cylinder block and while pushing it along the cylinder block, fit the claw into the cylinder block.

NOTICE:

- Make sure that the claw marks a click sound, indicating that it fits tightly.
- Replace the claw with a new one if it does not fit tightly or is deformed.

30. INSTALL FLYWHEEL HOUSING SIDE COVER (for 1.0 kW Type)

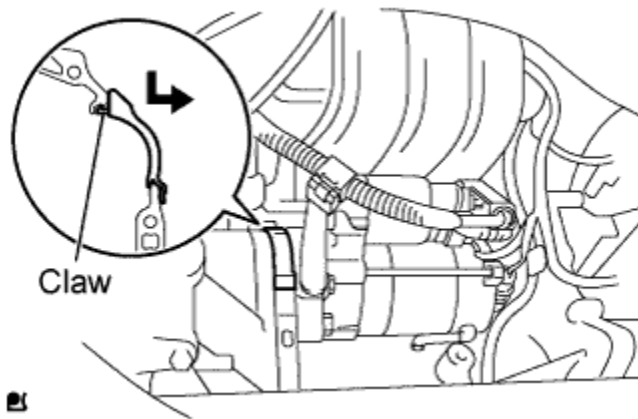

1. Insert the protruding portion into the end of the cylinder block and while pushing it along the cylinder block, fit the claw into the cylinder block.

NOTICE:

- Make sure that the claw makes a click sound, indicating that it fits tightly.
- Replace the claw with a new one if it does not fit tightly or is deformed.

31. INSTALL FLYWHEEL HOUSING SIDE COVER (for 1.3 kW Type)

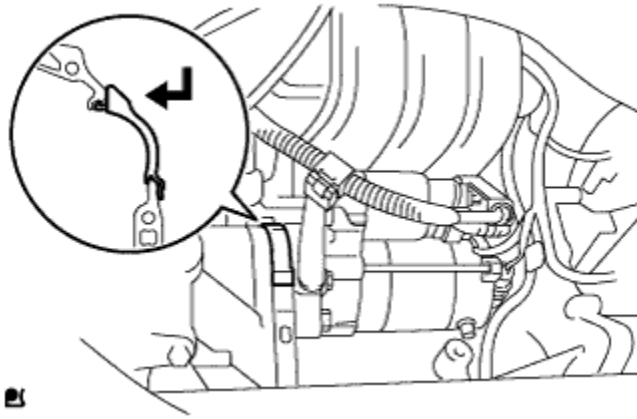

1. Insert the protruding portion into the end of the cylinder block and while pushing it along the cylinder block, fit the claw into the cylinder block.

NOTICE:

- Make sure that the claw makes a click sound, indicating that it fits tightly.
- Replace the claw with a new one if it does not fit tightly or is deformed.

| |
|--|
| 32. INSTALL ENGINE ASSEMBLY WITH TRANSAXLE |
|--|

1. Set the engine assembly with transaxle and the front suspension cross member on the engine lifter.
2. Operate the engine lifter and lift the engine assembly with transaxle and the front suspension cross member into the position where the engine mounting insulators RH and LH can be installed.

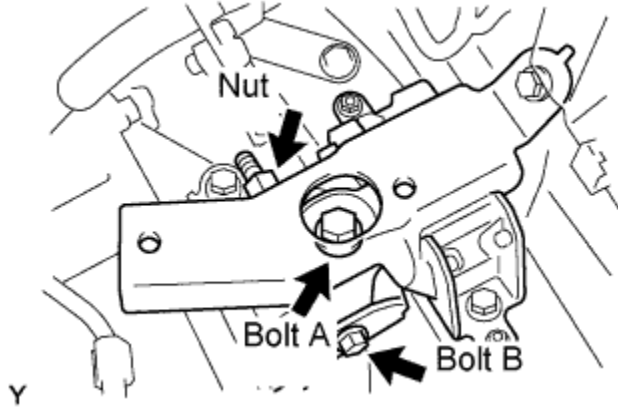

3. Install the engine mounting insulator LH with bolt B and the nut.

Torque:

52 N*m { 530 kgf*cm , 38 ft.*lbf }

4. Install the engine mounting insulator LH with bolt A.

Torque:

64 N*m { 653 kgf*cm , 47 ft.*lbf }

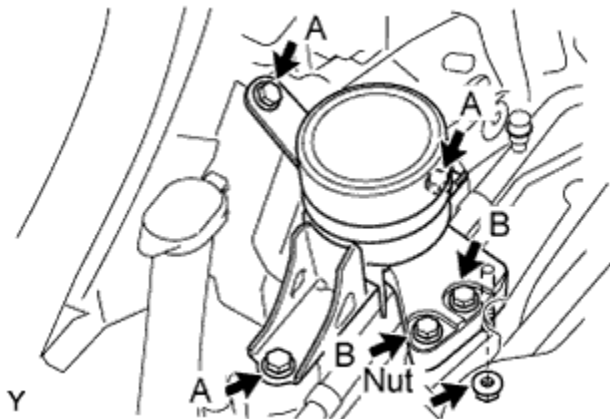

5. Provisionally install the engine mounting insulator RH with the 5 bolts and nut.

6. Tighten the 5 bolts and nut.

Torque:

Bolt A (for TMC Made):

45 N*m { 460 kgf*cm , 33 ft.*lbf }

Bolt B (for TMMF Made):

52 N*m { 530 kgf*cm , 38 ft.*lbf }

Bolt B:
52 N*m { 530 kgf*cm , 38 ft.*lbf }
Nut:
52 N*m { 530 kgf*cm , 38 ft.*lbf }

7. Operate the engine lifter and provisionally install the engine assembly with transaxle and the front suspension cross member onto the vehicle with the 6 bolts.

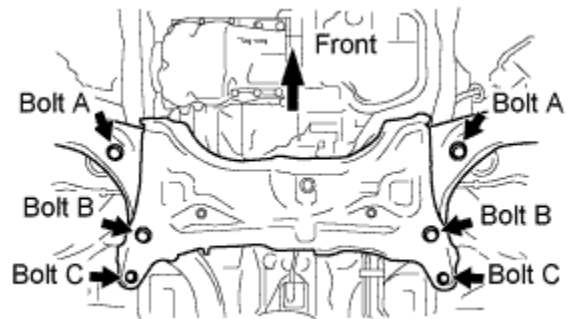

8. Insert SST into the datum holes of the front suspension cross member RH and LH alternately and tighten bolts A, B and C on both sides in several steps.

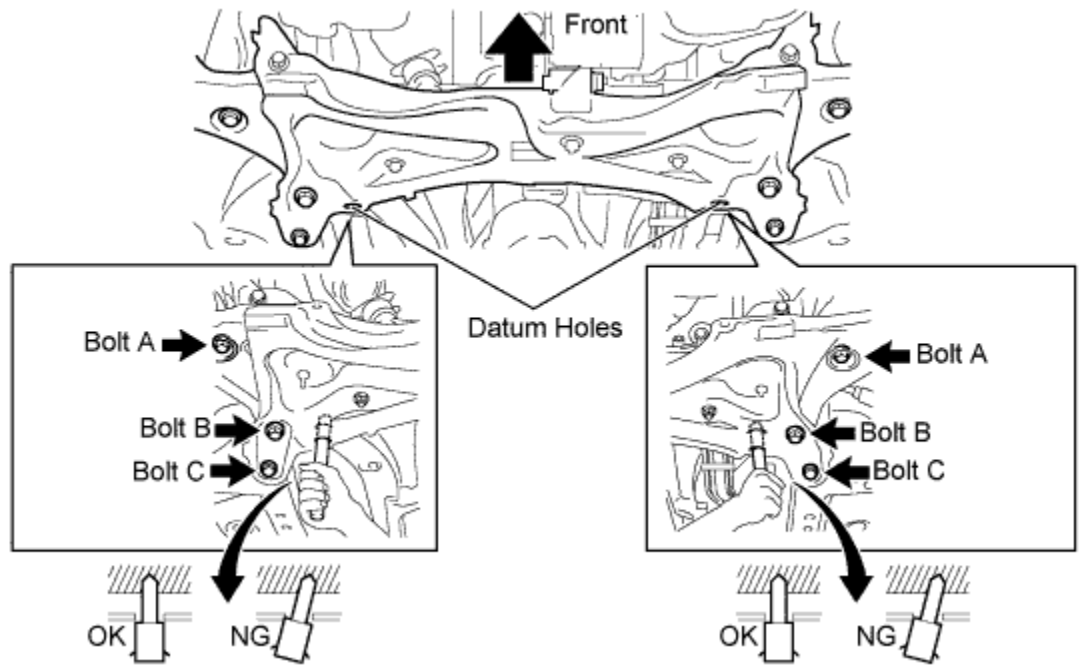

SST

09670-00010

Torque:

Bolt A:

70 N*m { 714 kgf*cm , 52 ft.*lbf }

Bolt B:

160 N*m { 1,631 kgf*cm , 118 ft.*lbf }

Bolt C:

95 N*m { 969 kgf*cm , 70 ft.*lbf }

CAUTION:

- Insert SST into the datum holes vertically.
- If impossible to insert SST vertically, loosen all the bolts and then insert SST again.

33. INSTALL WITH PULLEY COMPRESSOR ASSEMBLY (w/ Air Conditioning System)

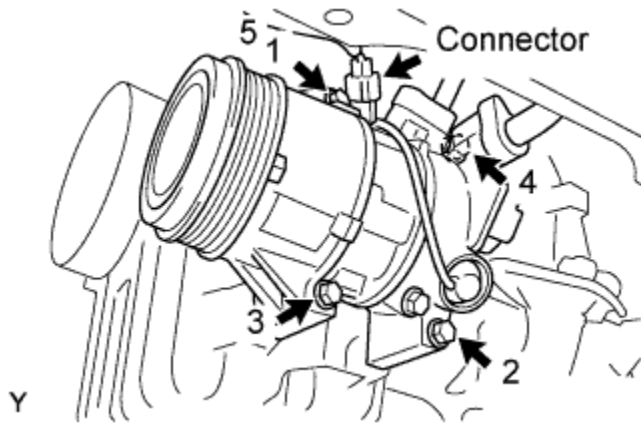

1. Install the compressor with the 4 bolts in the order shown in the illustration.

Torque:
25 N*m { 250 kgf*cm , 18 ft.*lbf }

2. Connect the connector.

34. INSTALL ENGINE WIRE

35. INSTALL ECM

1. Connect the ECM connector.

36. INSTALL STEERING COLUMN HOLE COVER SUB-ASSEMBLY NO. 1

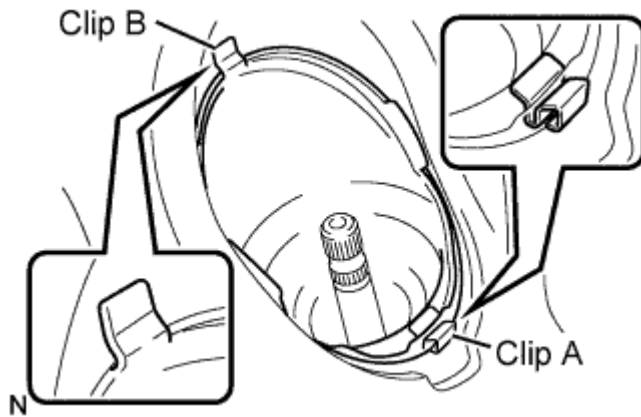

1. Install clip B onto the vehicle body and install the steering column hole cover onto the vehicle body with clip A.

NOTICE:

Fit the lip of the steering column hole cover correctly onto the dash panel.

37. INSTALL STEERING INTERMEDIATE SHAFT ASSEMBLY NO. 2

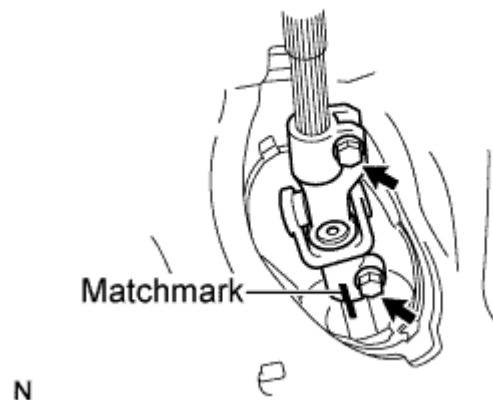

1. Align the matchmarks and install steering intermediate shaft onto the steering gear with the 2 bolts.

Torque:

28 N*m { 286 kgf*cm , 21 ft.*lbf }

38. INSTALL COLUMN HOLE COVER SILENCER SHEET

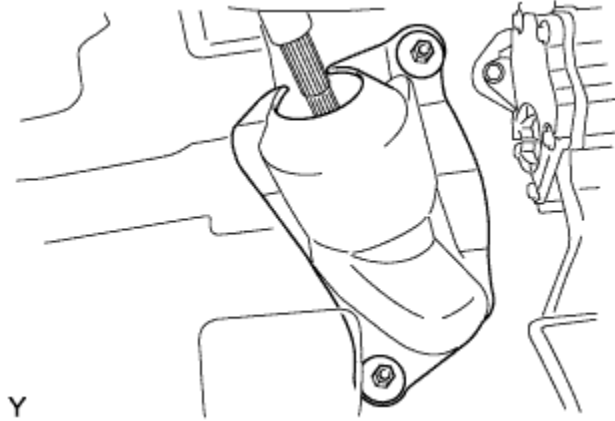

1. Install the column hole cover silencer sheet with the 2 clips.

39. INSTALL FRONT DRIVE SHAFT ASSEMBLY LH (for TMC Made)

1. for Automatic Transaxle:
 1. Coat the spline of the inboard joint with ATF.
2. for Manual Transaxle:
 1. Coat the spline of the inboard joint with gear oil.

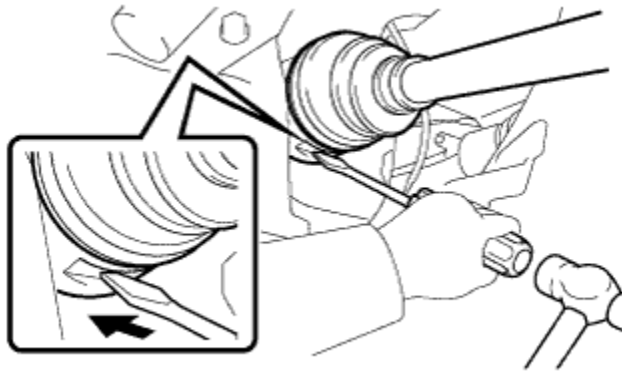

P

3. Align the inboard joint splines and install the drive shaft with a screwdriver and hammer.

NOTICE:

- Face the cut area of the front drive inboard joint hole snap ring downward.
- Do not damage the oil seal.
- Do not damage the inboard joint boot.

HINT:

Confirm whether the drive shaft is securely driven in by checking the reaction force and sound.

40. INSTALL FRONT DRIVE SHAFT ASSEMBLY LH (for TMMF Made)

1. Coat the spline of the inboard joint with gear oil.

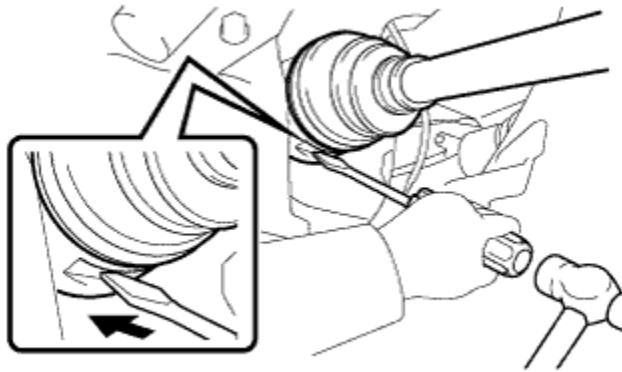

P

2. Align the inboard joint splines and install the drive shaft with a screwdriver and hammer.

NOTICE:

- Face the cut area of the front drive inboard joint hole snap ring downward.
- Do not damage the oil seal.
- Do not damage the inboard joint boot.

HINT:

Confirm whether the drive shaft is securely driven in by checking the reaction force and sound.

41. INSTALL FRONT DRIVE SHAFT ASSEMBLY RH (for TMC Made)

HINT:

The installation procedure for the RH side is the same as that for the LH side.

42. INSTALL FRONT DRIVE SHAFT ASSEMBLY RH (for TMMF Made)

HINT:

The installation procedure for the RH side is the same as that for the LH side.

43. INSTALL FRONT AXLE ASSEMBLY LH (for TMC Made)

1. Push the front axle out of the vehicle to align the spline of the drive shaft with the front axle and insert the front axle.

NOTICE:

- Do not push the front axle further out of the vehicle than is necessary.
- Do not damage the outboard joint boot.
- Check for any foreign matter on the speed sensor rotor and insertion part.
- Do not damage the speed sensor rotor.

44. INSTALL FRONT AXLE ASSEMBLY LH (for TMMF Made)

1. Push the front axle out of the vehicle to align the spline of the drive shaft with the front axle and insert the front axle.

NOTICE:

- Do not push the front axle further out of the vehicle than is necessary.
- Do not damage the outboard joint boot.
- Check for any foreign matter on the speed sensor rotor and insertion part.
- Do not damage the speed sensor rotor.

45. INSTALL FRONT AXLE ASSEMBLY RH (for TMC Made)

HINT:

The installation procedure for the RH side is the same as that for the LH side.

46. INSTALL FRONT AXLE ASSEMBLY RH (for TMMF Made)

HINT:

The installation procedure for the RH side is the same as that for the LH side.

47. INSTALL FRONT SUSPENSION ARM SUB-ASSEMBLY LOWER NO. 1 LH (for TMC Made)

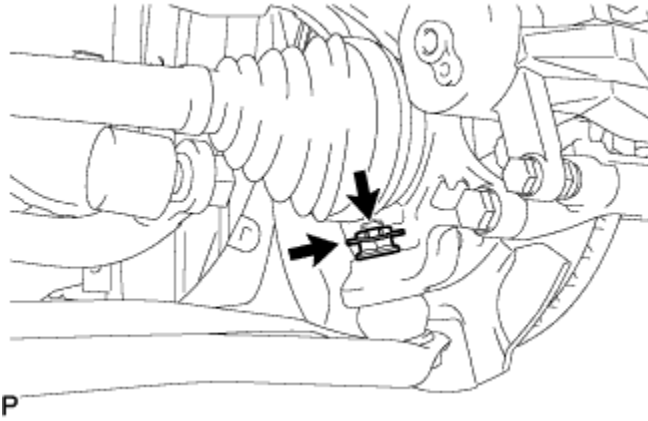

1. Install the lower arm onto the steering knuckle with a new castle nut.

Torque:

98 N*m { 1,000 kgf*cm , 72 ft.*lbf }

NOTICE:

If the holes for the clip are not aligned, tighten the nut by a further turn of up to 60°.

2. Install a new clip.

48. INSTALL FRONT SUSPENSION ARM SUB-ASSEMBLY LOWER NO. 1 LH (for TMMF Made)

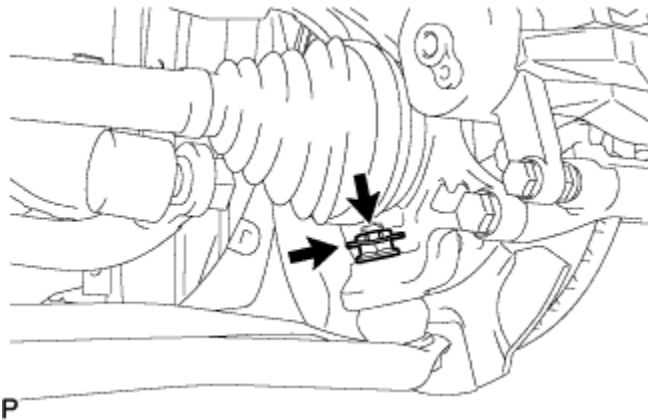

1. Install the lower arm onto the steering knuckle with a new castle nut.

Torque:

98 N*m { 1,000 kgf*cm , 72 ft.*lbf }

NOTICE:

If the holes for the clip are not aligned, tighten the nut by a further turn of up to 60°.

2. Install a new clip.

49. INSTALL FRONT SUSPENSION ARM SUB-ASSEMBLY LOWER NO. 1 RH (for TMC Made)

HINT:

The installation procedure for the RH side is the same as that for the LH side.

50. INSTALL FRONT SUSPENSION ARM SUB-ASSEMBLY LOWER NO. 1 RH (for TMMF Made)

HINT:

The installation procedure for the RH side is the same as that for the LH side.

51. INSTALL FRONT STABILIZER LINK ASSEMBLY LH (for TMC Made)

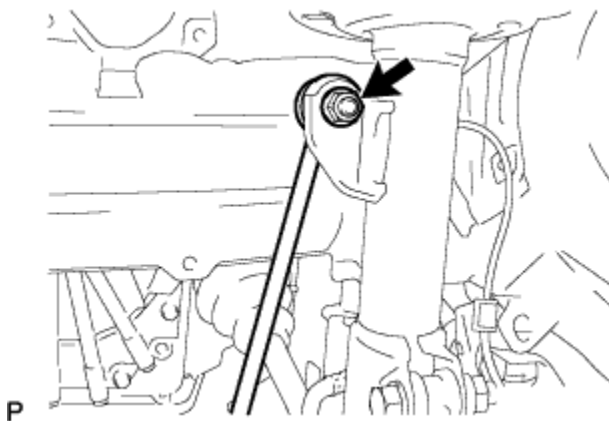

1. Install the stabilizer link with the nut.

Torque:

74 N*m { 755 kgf*cm , 55 ft.*lbf }

HINT:

If the ball joint turns together with the nut, use a socket hexagon wrench 6 to hold the stud.

52. INSTALL FRONT STABILIZER LINK ASSEMBLY LH (for TMMF Made)

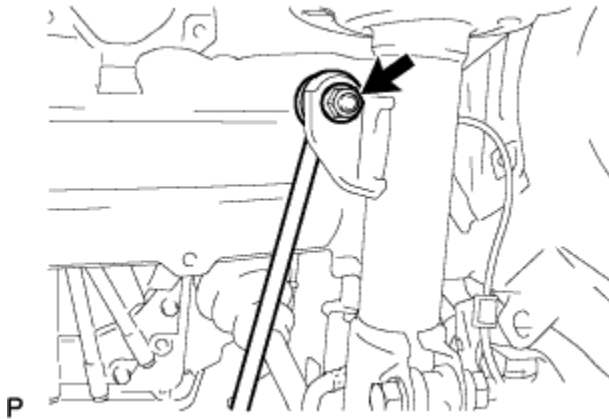

1. Install the stabilizer link with the nut.

Torque:

74 N*m { 755 kgf*cm , 55 ft.*lbf }

HINT:

If the ball joint turns together with the nut, use a socket hexagon wrench 6 to hold the stud.

53. INSTALL FRONT STABILIZER LINK ASSEMBLY RH (for TMC Made)

HINT:

The installation procedure for the RH side is the same as that for the LH side.

54. INSTALL FRONT STABILIZER LINK ASSEMBLY RH (for TMMF Made)

HINT:

The installation procedure for the RH side is the same as that for the LH side.

55. INSTALL TIE ROD END SUB-ASSEMBLY LH (for TMC Made)

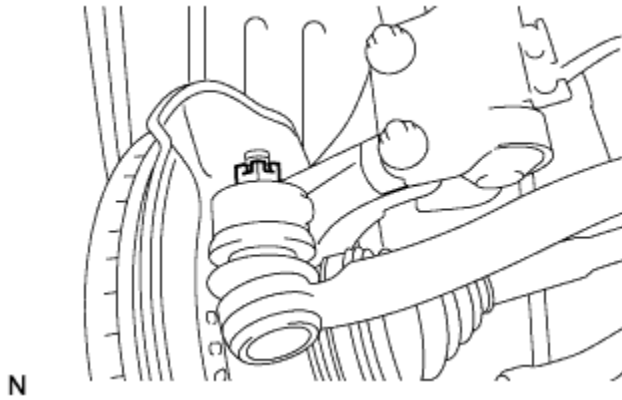

1. Install the tie rod end onto the steering knuckle with a new castle nut.

Torque:

49 N*m { 500 kgf*cm , 36 ft.*lbf }

NOTICE:

If the holes for the clip are not aligned, tighten the nut by a further turn of up to 60°.

2. Install a new cotter pin.

56. INSTALL TIE ROD END SUB-ASSEMBLY LH (for TMMF Made)

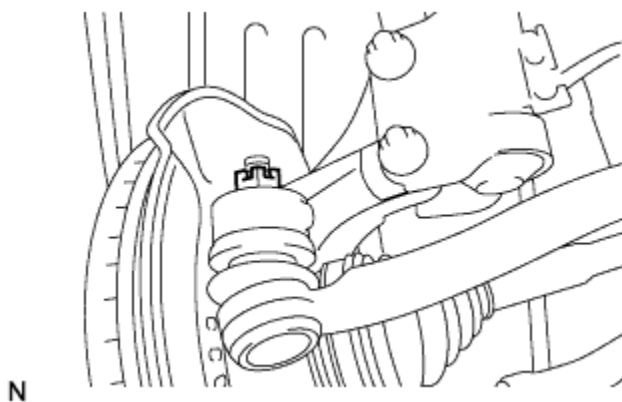

1. Install the tie rod end onto the steering knuckle with a new castle nut.

Torque:

49 N*m { 500 kgf*cm , 36 ft.*lbf }

NOTICE:

If the holes for the clip are not aligned, tighten the nut by a further turn of up to 60°.

2. Install a new cotter pin.

57. INSTALL TIE ROD END SUB-ASSEMBLY RH (for TMC Made)

HINT:

The installation procedure for the RH side is the same as that for the LH side.

58. INSTALL TIE ROD END SUB-ASSEMBLY RH (for TMMF Made)

HINT:

The installation procedure for the RH side is the same as that for the LH side.

59. INSTALL SPEED SENSOR FRONT LH (for TMC Made)

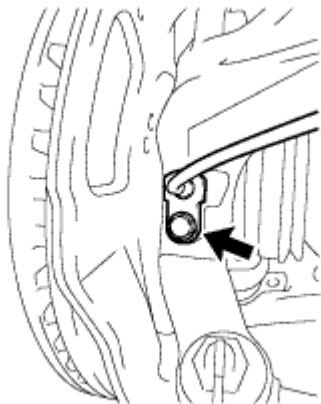

P

1. Install the speed sensor onto the steering knuckle with the bolt.

Torque:

8.5 N*m { 87 kgf*cm , 75 in.*lbf }
NOTICE:

- Check that the speed sensor tip and installation portion are free of foreign matter.
- Install the speed sensor without turning it from its original installation angle.

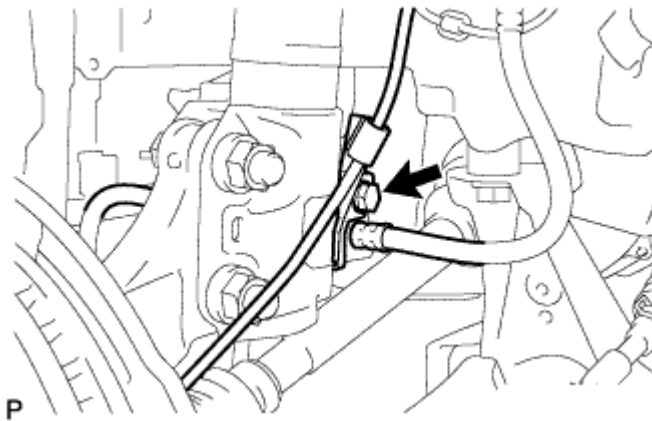

2. Install the flexible hose and speed sensor with the bolt.

Torque:
29 N*m { 300 kgf*cm , 22 ft.*lbf }

NOTICE:

Install the flexible hose and speed sensor without twisting them.

| |
|---|
| 60. INSTALL SPEED SENSOR FRONT LH (for TMMF Made) |
|---|

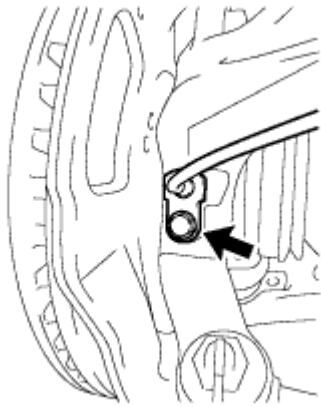

P

1. Install the speed sensor onto the steering knuckle with the bolt.

Torque:

8.5 N*m { 87 kgf*cm , 75 in.*lbf }

NOTICE:

- Check that the speed sensor tip and installation portion are free of foreign matter.
- Install the speed sensor without turning it from its original installation angle.

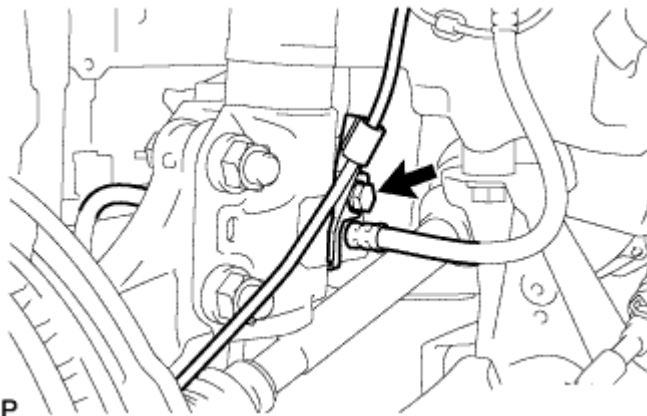

P

2. Install the flexible hose and speed sensor with the bolt.

Torque:

29 N*m { 300 kgf*cm , 22 ft.*lbf }

NOTICE:

Install the flexible hose and speed sensor without twisting them.

61. INSTALL SPEED SENSOR FRONT RH (for TMC Made)

HINT:

The installation procedure for the RH side is the same as that for the LH side.

62. INSTALL SPEED SENSOR FRONT RH (for TMMF Made)

HINT:

The installation procedure for the RH side is the same as that for the LH side.

63. INSTALL FRONT AXLE SHAFT LH NUT (for TMC Made)

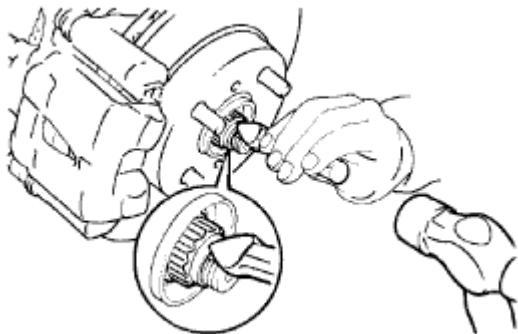

T

C57566

1. Using a 30 mm socket wrench, install a new axle hub nut.

Torque:

216 N*m { 2,203 kgf*cm , 160 ft.*lbf }

2. Using a chisel and hammer, caulk the axle hub nut.

64. INSTALL FRONT AXLE SHAFT LH NUT (for TMMF Made)

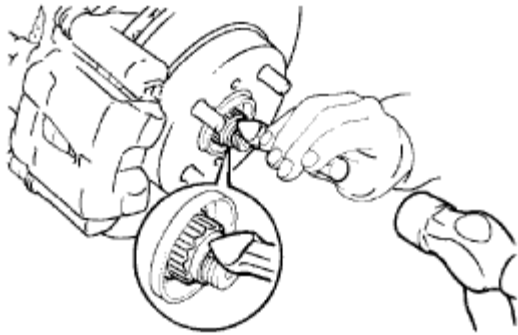

T

C57566

1. Using a 30 mm socket wrench, install a new axle hub nut.

Torque:

216 N*m { 2,203 kgf*cm , 160 ft.*lbf }

2. Using a chisel and hammer, caulk the axle hub nut.

65. INSTALL FRONT AXLE SHAFT RH NUT (for TMC Made)

HINT:

The installation procedure for the RH side is the same as that for the LH side.

66. INSTALL FRONT AXLE HUB RH NUT (for TMMF Made)

HINT:

The installation procedure for the RH side is the same as that for the LH side.

67. CONNECT FUEL TUBE SUB-ASSEMBLY

1. Connect the fuel tube connector and fuel pipe, and install fuel pipe clamp No. 1.

CAUTION:

Align the fuel tube connector with the pipe, then push the fuel tube connector in until the retainer makes a click sound. If the connection is tight, apply a small amount of engine oil to the tip of the pipe. After connecting, pull the pipe and connector to make sure that they are securely connected.

68. CONNECT HEATER WATER INLET HOSE A

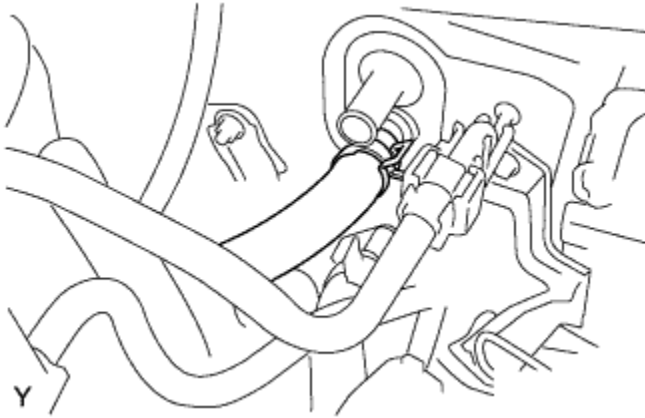

69. CONNECT HEATER WATER OUTLET HOSE A(FROM HEATER UNIT)

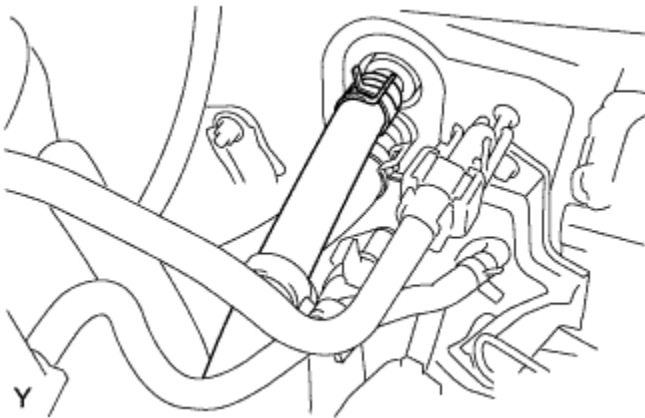

70. CONNECT RADIATOR HOSE NO. 1

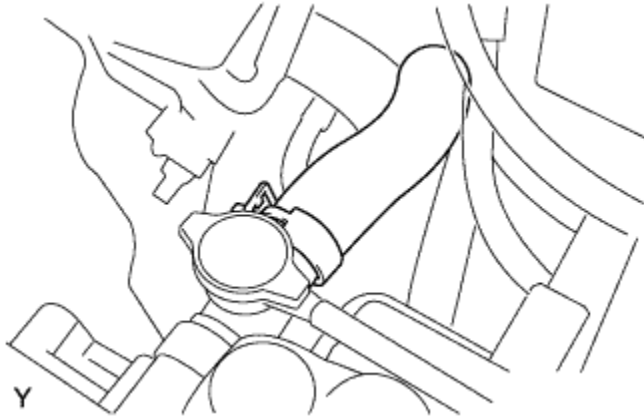

71. CONNECT RADIATOR HOSE NO. 2



72. CONNECT CONNECTOR (for Multi-Mode Manual Transaxle)

1. Connect the shift and select motor connectors.
2. Connect the neutral start switch connector.
3. Connect the back-up light switch connector.
4. Connect the transmission revolution sensor connector.
5. Connect the select stroke sensor connector.

6. Connect the shift stroke sensor connector.

73. CONNECT WIRE HARNESS (for Multi-Mode Manual Transaxle)

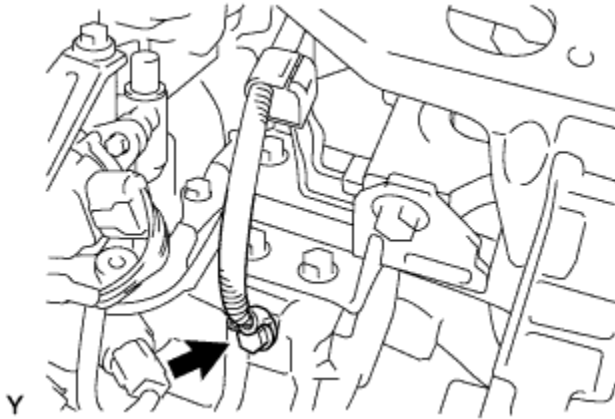

1. Connect the wire harness with the bolt.

Torque:

26 N*m { 260 kgf*cm , 19 ft.*lbf }

74. INSTALL TRANSMISSION CONTROL CABLE ASSEMBLY (for Manual Transaxle)

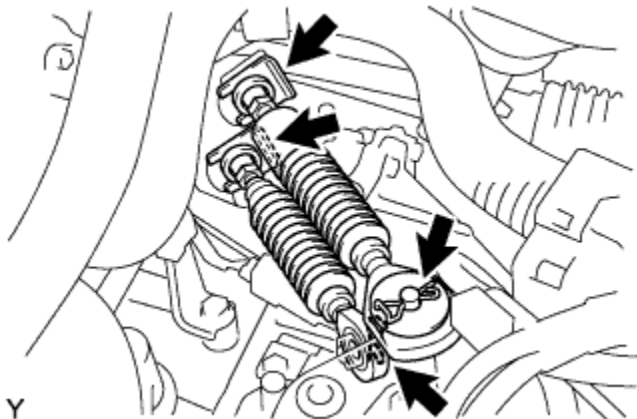

1. Connect the 2 cable ends, and install the 2 washers and the 2 clips.
2. Install the 2 new clips onto the control cable bracket.

75. INSTALL CLUTCH RELEASE CYLINDER ASSEMBLY (for Manual Transaxle)

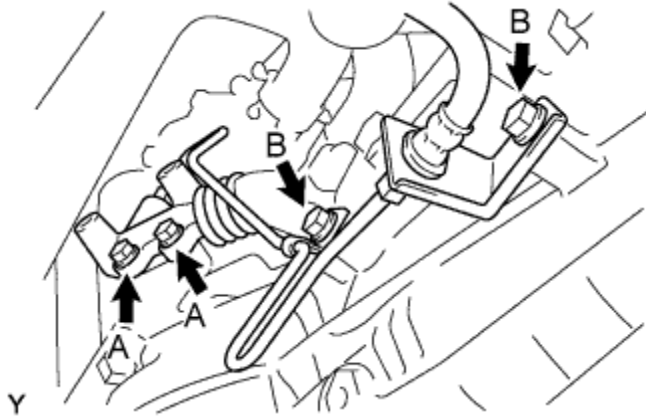

1. Install the clutch release cylinder and clutch pipe with the 4 bolts.

Torque:

Bolt A:

12 N*m { 120 kgf*cm , 8.7 ft.*lbf }

Bolt B:

19 N*m { 194 kgf*cm , 14 ft.*lbf }

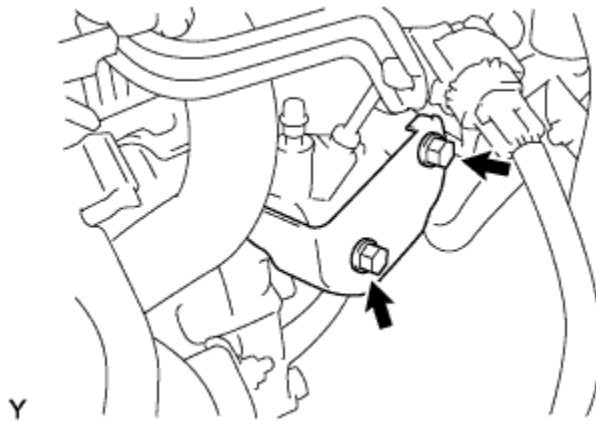

2. Install the release cylinder heat insulator with the 2 bolts.

Torque:

12 N*m { 120 kgf*cm , 8.7 ft.*lbf }

76. CONNECT BOOSTER VACUUM TUBE

1. Connect the booster vacuum hose to the intake manifold.

77. CONNECT FUEL VAPOR FEED HOSE NO. 1

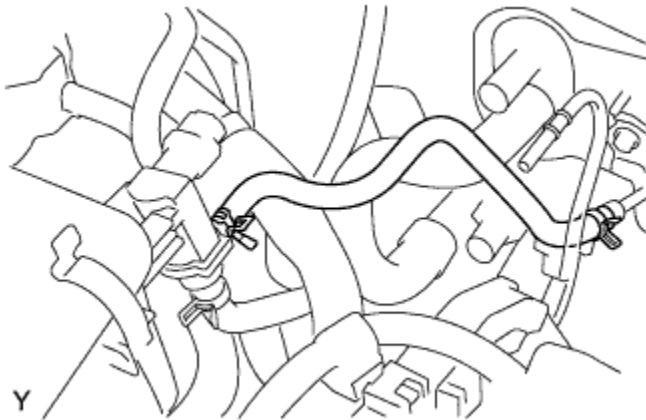

78. INSTALL FAN BELT ADJUSTING BAR

1. Install the fan belt adjusting bar with the bolt.

Torque:

34 N*m { 347 kgf*cm , 25 ft.*lbf }

79. INSTALL GENERATOR ASSEMBLY

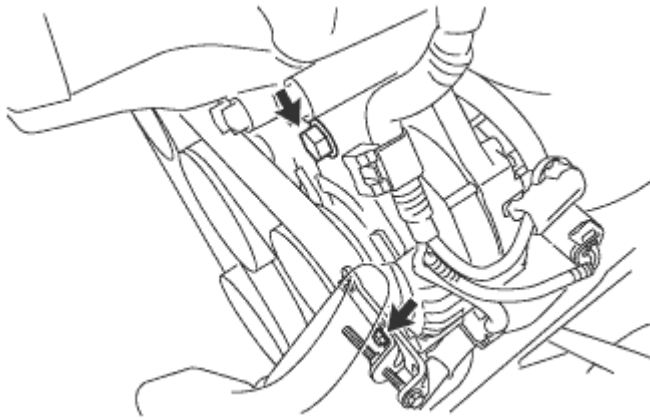

1. Provisionally install the generator with the 2 bolts.

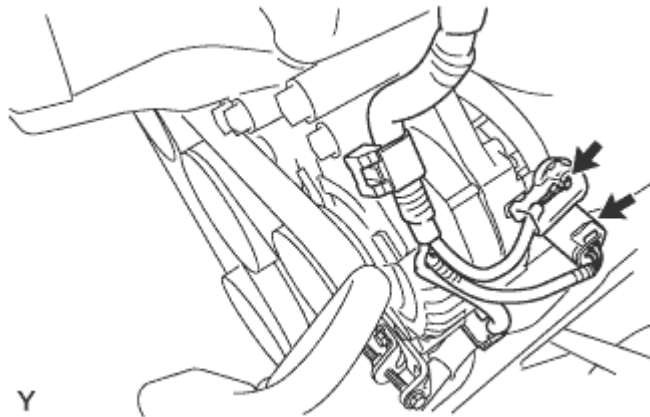

2. Install terminal B with the nut.

Torque:
7.8 N*m { 80 kgf*cm , 69 in.*lbf }

3. Connect the connector.
4. Engage the 2 clamps onto the generator.

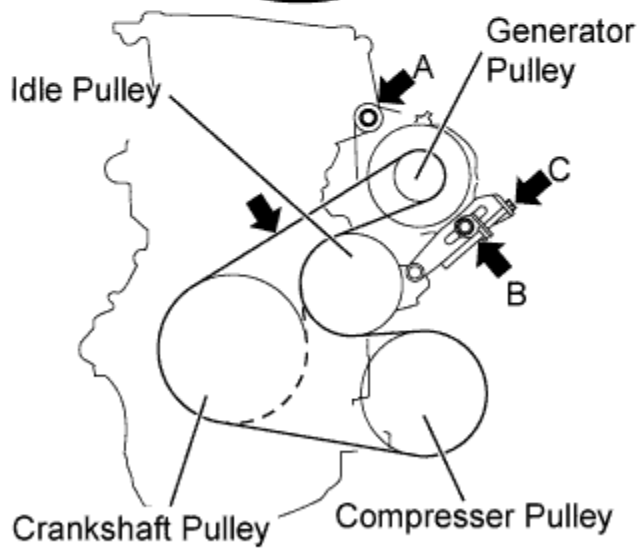
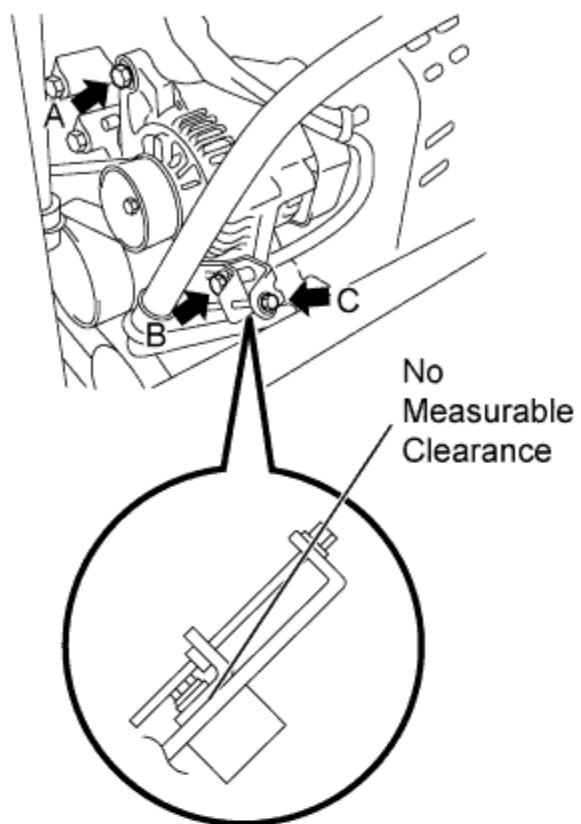

—— w/ Air Conditioner
 - - - - w/o Air Conditioner

c

1. Install the fan and generator V belt.

2. Gently tighten bolt B until there is no measurable clearance.
3. Turn bolt C to adjust the tension of the fan and generator V belt.
4. Inspect the fan and generator V belt.
5. Tighten bolt B.

Torque:

34 N*m { 347 kgf*cm , 25 ft.*lbf }

6. Tighten bolt A.

Torque:

54 N*m { 551 kgf*cm , 40 ft.*lbf }

7. Visually check the generator wiring and listen for abnormal noise.
 1. Check that the wiring is in good condition.
 2. Check that there is no abnormal noise from the generator while the engine is running.



Correct

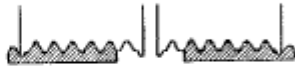

Wrong Wrong

8. Inspect the discharge warning light circuit.
 1. Turn the ignition switch to the ON position. Check that the discharge warning light illuminates.
 2. Start the engine. Check that the light goes off.

81. INSTALL VENTILATION HOSE NO. 2

1. Install ventilation hose No. 2 with the clip.

82. INSTALL AIR CLEANER FILTER ELEMENT SUB-ASSEMBLY

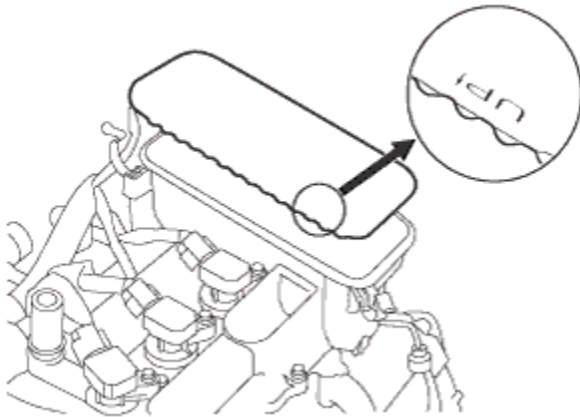

1. Install the air cleaner filter element as shown in the illustration.

83. INSTALL AIR CLEANER CAP SUB-ASSEMBLY

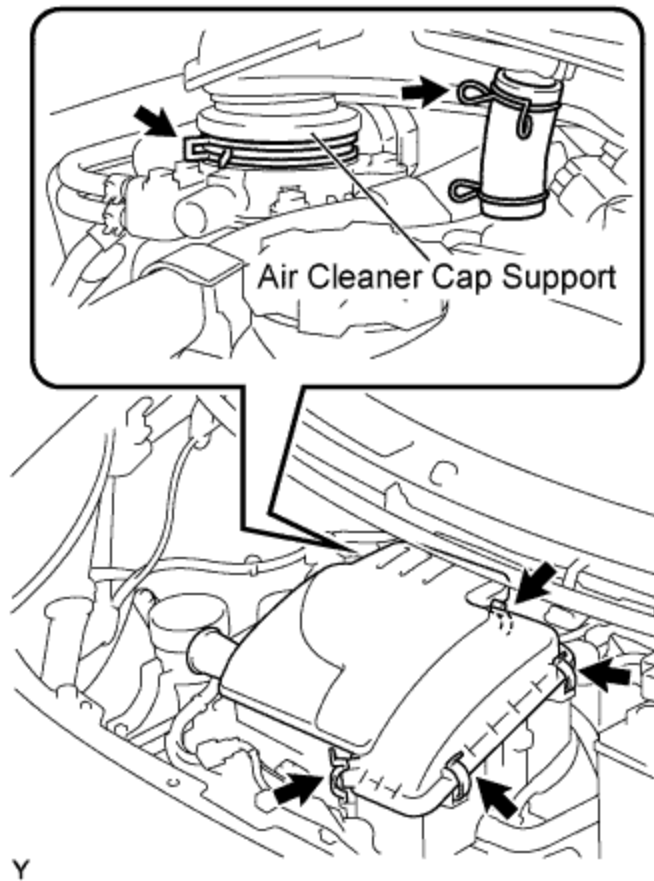

Y

1. Install the air cleaner cap with the 2 clamps.
2. Tighten the 4 clamps.

84. INSTALL COWL TOP PANEL OUTER

1. Install the cowl top panel outer with the 9 bolts.

Torque:
6.5 N*m { 66 kgf*cm , 58 in.*lbf }

2. Engage the clamp and install the wiper motor connector wire harness.

85. INSTALL COWL TO REGISTER DUCT SUB-ASSEMBLY NO. 2

for LHD:

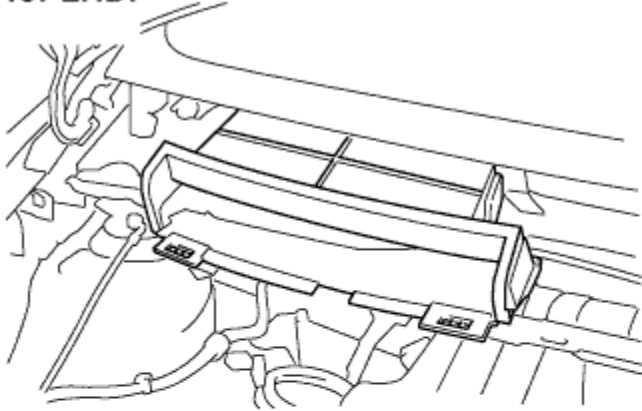

for RHD:

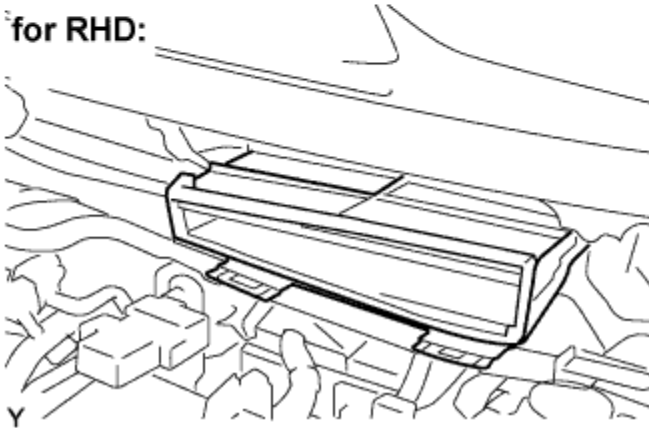

1. Engage the claws, and install cowl to register duct No. 2.

86. INSTALL FRONT WINDOW WIPER MOTOR AND LINK

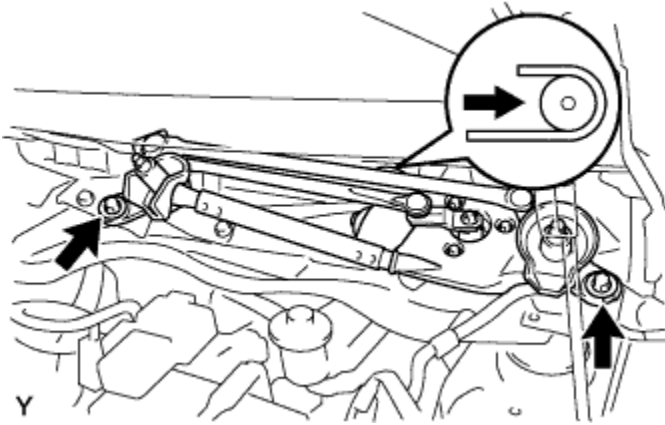

1. Connect the connector.
2. Slide the wiper link as shown in the illustration and engage the rubber pin with the body.
3. Install the front wiper motor and link with the 2 bolts.

Torque:
 5.5 N*m { 56 kgf*cm , 49 in.*lbf }

87. INSTALL COWL TOP VENTILATOR LOUVER LH (for LHD)

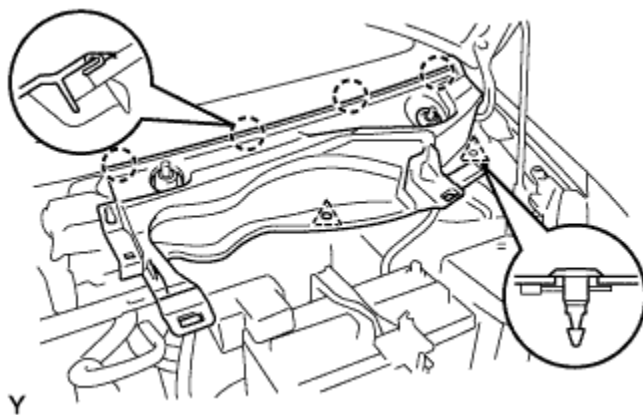

1. Engage the 4 claws and install the cowl top ventilator louver LH.
2. Install the 2 clips.

88. INSTALL COWL TOP VENTILATOR LOUVER SUB-ASSEMBLY (for LHD)

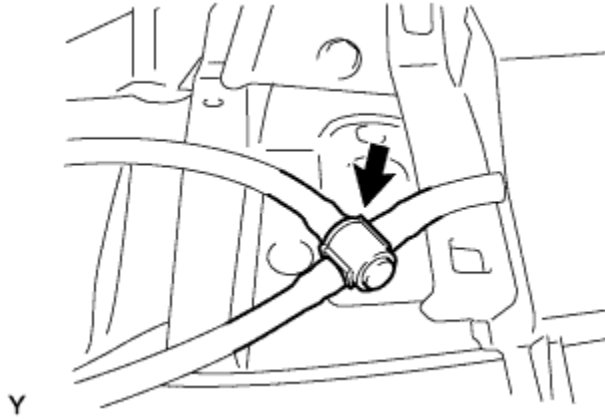

1. Connect the washer hose.

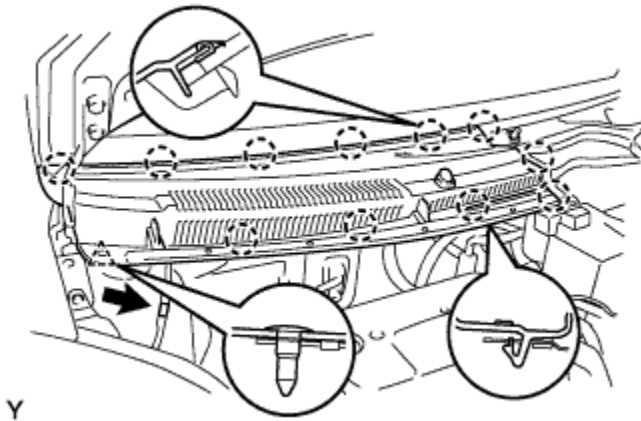

2. Engage the 11 claws and install the cowl top ventilator louver sub-assembly.
3. Install the clip.
4. Connect the washer hose.

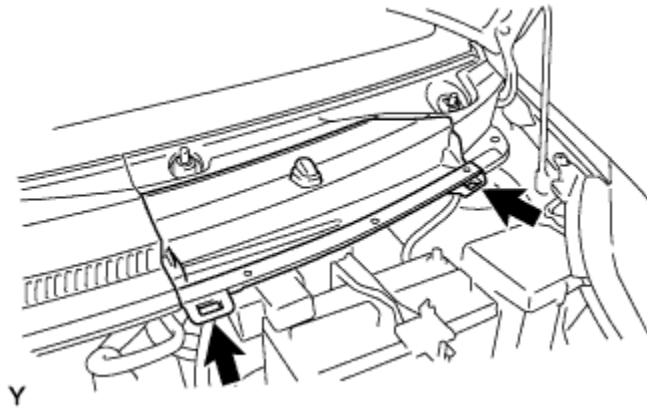

5. Engage the 2 hooks and install cowl top ventilator louver center No. 1.

89. INSTALL COWL TOP VENTILATOR LOUVER LH (for RHD)

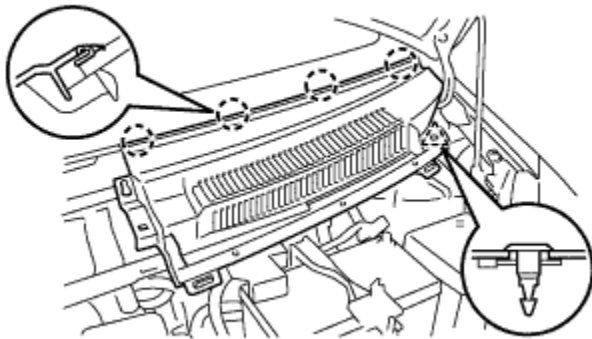

1. Engage the 4 claws and install the cowl top ventilator louver LH.
2. Install the clip.

90. INSTALL COWL TOP VENTILATOR LOUVER SUB-ASSEMBLY (for RHD)

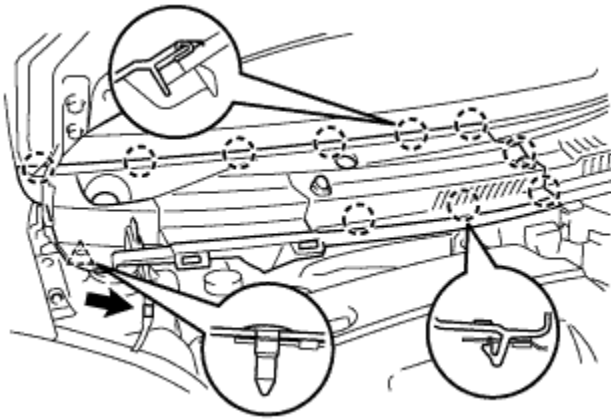

Y

1. Engage the 10 claws and install the cowl top ventilator louver sub-assembly.
2. Install the clip.
3. Connect the washer hose.

91. INSTALL HOOD TO COWL TOP SEAL

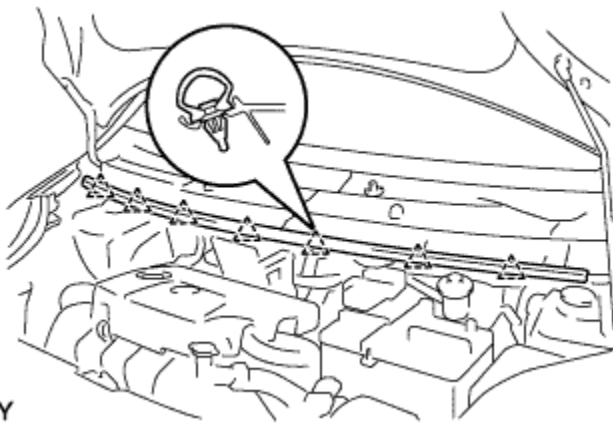

Y

1. Engage the 7 clips and install the hood to cowl top seal.

92. INSTALL FRONT WIPER ARM AND BLADE ASSEMBLY LH

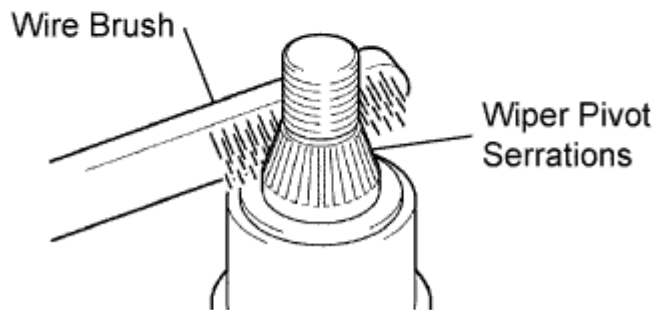
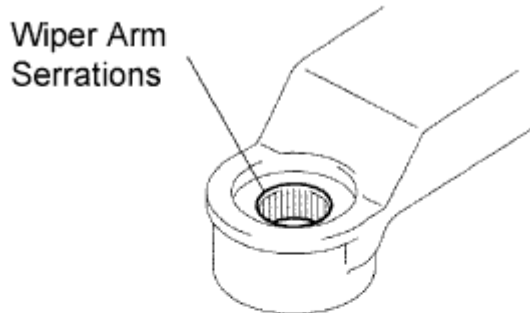

P

1. Scrape any metal powder off the serrated part of the wiper arm with a round file or the equivalent (when reinstalling).
2. Clean the wiper pivot serrations with a wire brush.
3. Operate the wiper, then stop the windshield wiper motor in the automatic stop position.

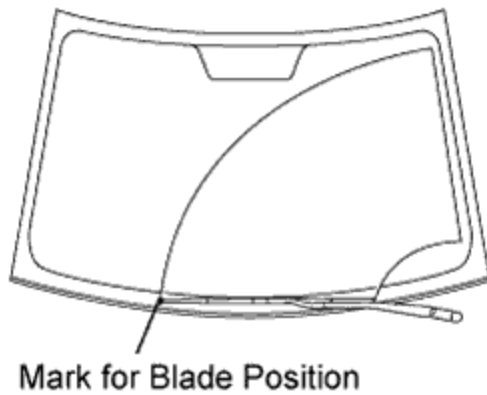

Y

4. Align the blade tip with the mark on the windshield glass, as shown in the illustration.
5. Tighten the nut of the front wiper arm.

Torque:

26 N*m { 265 kgf*cm , 19 ft.*lbf }

93. INSTALL FRONT WIPER ARM AND BLADE ASSEMBLY RH

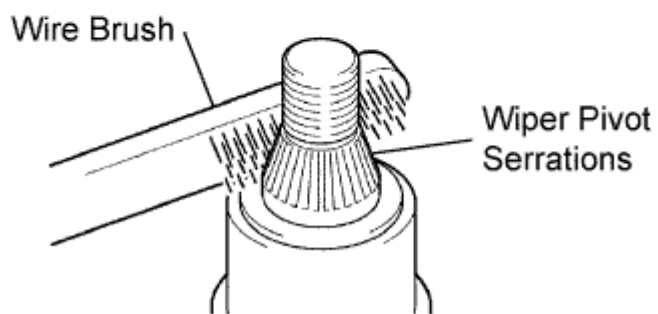
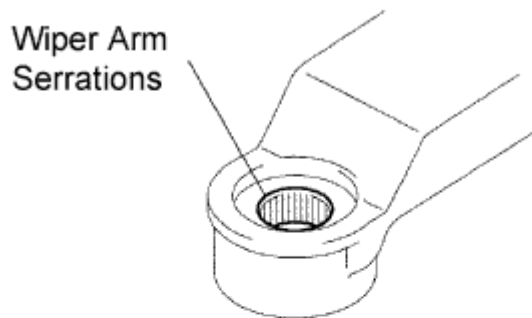

P

1. Scrape any metal powder off the serrated part of the wiper arm with a round file or the equivalent (when reinstalling).
2. Clean the wiper pivot serrations with a wire brush.
3. Operate the wiper, then stop the windshield wiper motor in the automatic stop position.

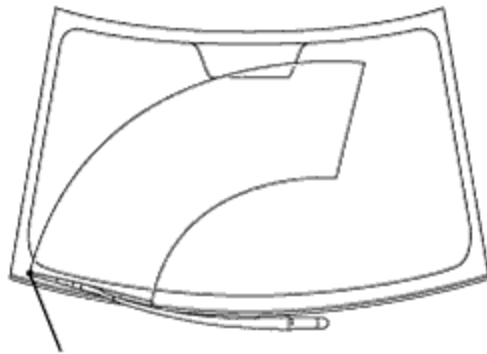

Mark for Blade Position

Y

4. Align the blade tip with the mark on the windshield glass, as shown in the illustration.
5. Tighten the nut of the front wiper arm.

Torque:

26 N*m { 265 kgf*cm , 19 ft.*lbf }

94. INSTALL FRONT WIPER ARM HEAD CAP

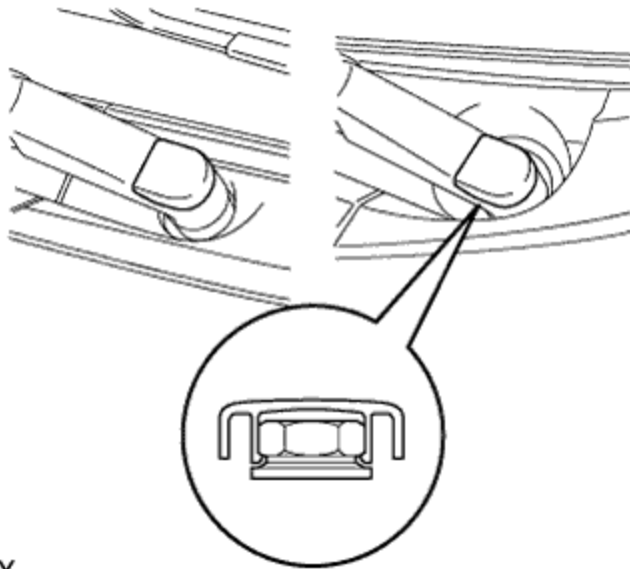

Y

1. Engage the claw and install the 2 front wiper arm head caps.

95. INSTALL FRONT WHEELS

Torque:

103 N*m { 1,050 kgf*cm , 76 ft.*lbf }

96. INSTALL EXHAUST PIPE ASSEMBLY FRONT

1. Using vernier calipers, measure the free length of the compression spring.

Minimum length:

Front side:

40.5 mm (1.594 in.)

Rear side:

38.5 mm (1.516 in.)

If the free length is less than the minimum, replace the compression spring.

2. Install a new gasket onto the rear side of the exhaust pipe front.

NOTICE:

- Install the gasket in the correct direction.
- Do not reuse the gasket.
- To ensure a proper seal, do not use the tailpipe to force the gasket onto the exhaust pipe front.

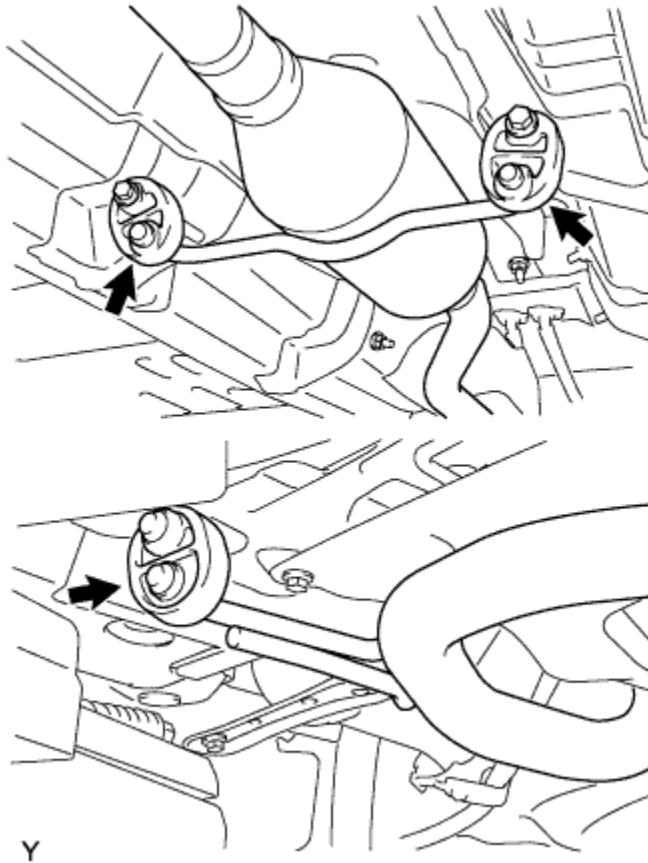

3. Install the 3 supports, and install the exhaust pipe front.

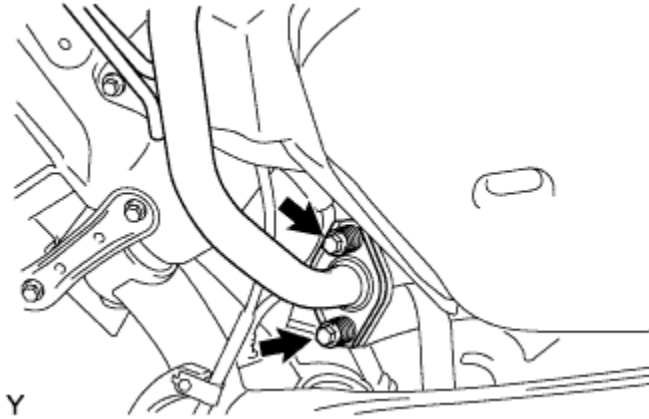

4. Install the exhaust pipe front onto the exhaust pipe tail with the 2 bolts and compression springs.

Torque:

43 N*m { 438 kgf*cm , 32 ft.*lbf }

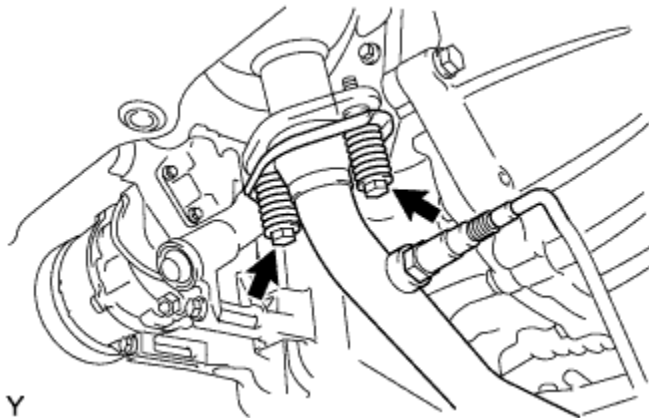

5. Install the exhaust pipe front onto the exhaust manifold with the 2 bolts and compression springs.

Torque:

43 N*m { 438 kgf*cm , 32 ft.*lbf }

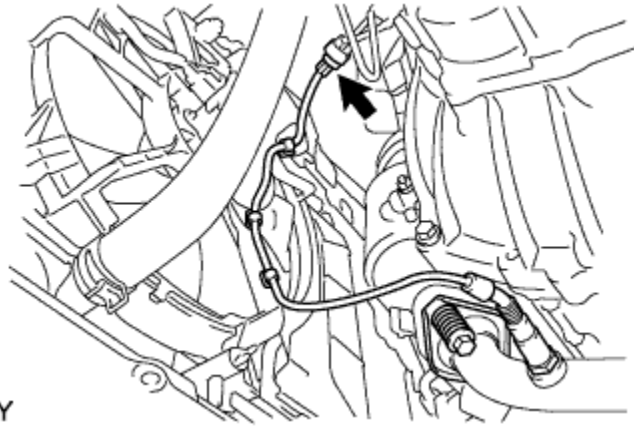

6. Connect the oxygen sensor connector, and engage the 3 wire harness clamps.

97. INSTALL EGR INLET EXHAUST MANIFOLD PLATE

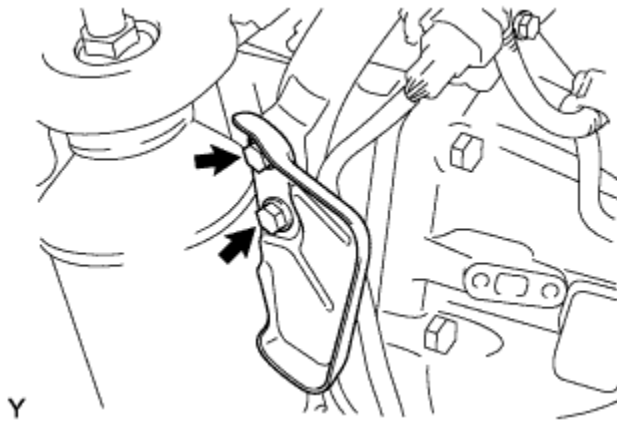

1. Install the EGR inlet exhaust manifold plate with the 2 bolts.

Torque:
18 N*m { 184 kgf*cm , 13 ft.*lbf }

98. INSTALL BATTERY CARRIER

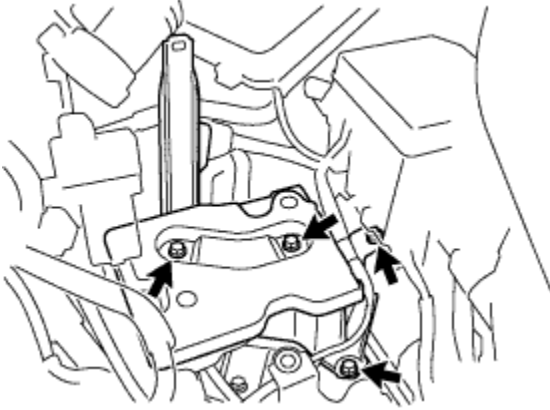

1. Install the battery carrier with the 4 bolts.

Torque:
17 N*m { 174 kgf*cm , 13 ft.*lbf }

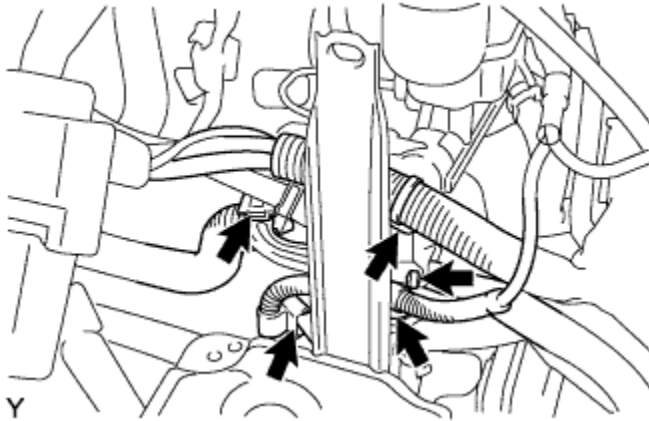

2. Engage the 5 clamps, and install the engine wire harness.

99. INSTALL BATTERY TRAY

100. INSTALL BATTERY

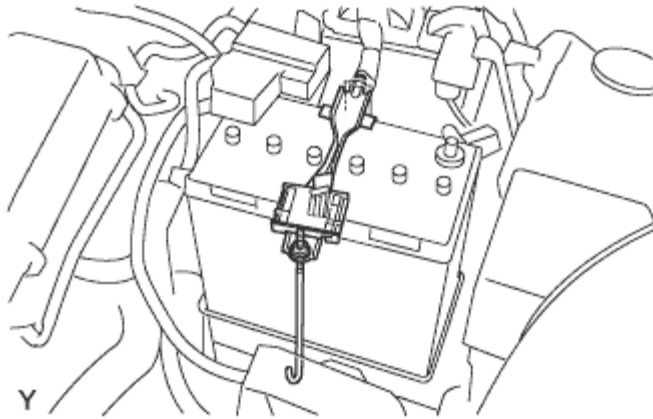

1. Install the battery onto the battery tray.
2. Install the battery carrier clamp with the nut.

Torque:

3.5 N*m { 36 kgf*cm , 31 in.*lbf }

3. Install the positive and negative terminals.

Torque:

5.4 N*m { 55 kgf*cm , 48 in.*lbf }

101. ADD ENGINE COOLANT

1. Tighten all the plugs.
2. Disconnect the vinyl hose.
3. Pour engine coolant into the radiator assembly until it overflows.

Capacity:

4.5 liters (4.8 USqts, 4.2 Imp. qts)

NOTICE:

Do not substitute water for engine coolant.

HINT:

- Use of improper engine coolant may damage the engine coolant system.
- Use only Toyota Super Long Life Coolant or similar high quality ethylene glycol based non-silicate, non-amine, non-nitrite, and non-borate engine coolant with long-life hybrid organic acid technology (coolant with long-

life hybrid organic acid technology consists of a combination of low phosphates and organic acids).

4. Check the engine coolant level inside the radiator assembly by squeezing the inlet and outlet radiator hoses several times by hand. If the engine coolant level goes down, add engine coolant.
5. Install the radiator cap sub-assembly securely.
6. Slowly pour engine coolant into the radiator reservoir until it reaches the FULL line.
7. Warm up the engine until the cooling fan operates.
 1. Set the air conditioning as follows while warming up the engine.

| Item | Manual air conditioning system | Automatic air conditioning system |
|------------------------|--|--|
| Set control as follows | Fan speed - Any setting except "OFF" Temperature - Toward WARM Air conditioning switch "OFF" | Fan speed - Any setting except "OFF" Temperature - To the highest temperature Air conditioning switch "OFF" "AUTO" switch "OFF" |

2. Maintain the engine speed at 2,000 to 2,500 rpm and warm up the engine until the cooling fan operates.
8. Stop the engine and wait until the coolant cools down.
9. If the engine coolant level is below the full level, perform steps (c) through (h) again and repeat the operation until the engine coolant level stays at the full level.
10. Recheck the engine coolant level inside the radiator reservoir tank assembly. If it is below the full level, add engine coolant.

| |
|-------------------------------|
| 102. ADD MANUAL TRANSAXLE OIL |
|-------------------------------|

103. INSPECT MANUAL TRANSAXLE OIL

1. Stop the vehicle in a level place.
2. Remove the transmission filler plug and the gasket.

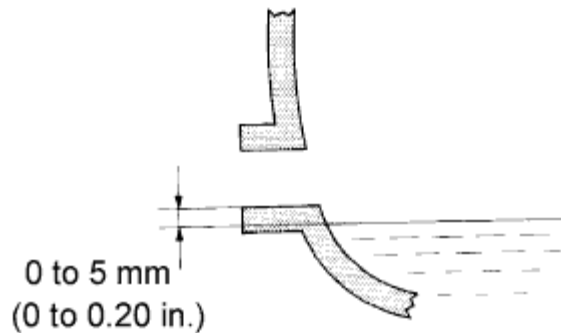

3. Check that the oil surface is within 5 mm (0.20 in.) of the bottom of the transmission filler plug opening.

NOTICE:

- Excessively large or small amounts of oil may cause problems.
 - After replacing the oil, drive the vehicle and check the oil level again.
4. Check for oil leakage if the oil level is low.
 5. Install the transmission filler plug and a new gasket.

Torque:

39 N*m { 400 kgf*cm , 29 ft.*lbf }

104. ADD ENGINE OIL

1. Fill with new engine oil.

Oil capacity:

| Item | Specification |
|------|---------------|
|------|---------------|

| | |
|---------------------------|---|
| With oil filter change | 3.1 liter (3.3 Us qts, 2.7 Imp. qts) |
| Without oil filter change | 2.9 liter (3.1 Us qts, 2.6 Imp. qts) |
| Dry fill | 3.4 liter (3.6 Us qts, 3.0 Imp. qts) |

105. INITIALIZATION OF MULTI-MODE MANUAL TRANSAXLE ECU (for Multi-Mode Manual Transaxle)

()

106. LEARNING OF MULTI-MODE MANUAL TRANSAXLE SYSTEM (for Multi-Mode Manual Transaxle)

()

107. SYNCHRONIZATION POSITION CALIBRATION (for Multi-Mode Manual Transaxle)

()

108. CHECK FOR ENGINE COOLANT LEAKAGE

CAUTION:

To avoid the danger of being burned, do not remove the radiator cap sub-assembly while the engine and radiator assembly are still hot. Thermal expansion will cause hot engine coolant and steam to blow out from the radiator assembly.

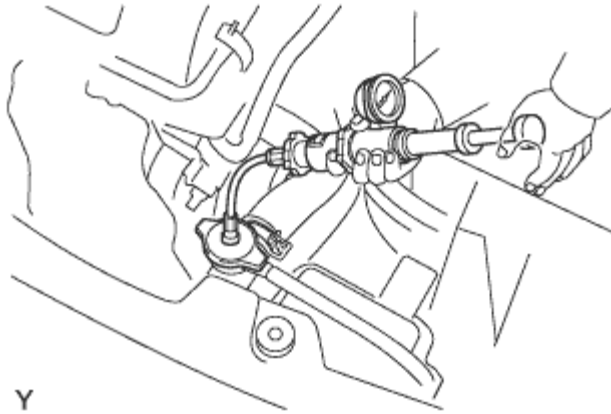

1. Fill the radiator assembly with engine coolant, then attach a radiator cap tester.
2. Pump it to 137 kPa (1.4 kgf/cm², 19.9 psi), then check that the pressure does not drop.
If the pressure drops, check the hoses, radiator assembly and water pump assembly for leakage. If there are no signs or traces of external engine coolant leakage, check the heater core, cylinder block and head.

109. CHECK FOR MANUAL TRANSAXLE OIL LEAKAGE

110. CHECK FOR ENGINE OIL LEAKAGE

111. CHECK FOR EXHAUST GAS LEAKAGE

112. INSPECT IGNITION TIMING

NOTICE:

- Turn all the electrical systems and the A/C off.
 - Inspect the ignition timing with the cooling fan off.
 - When checking the ignition timing, shift the transmission to the neutral position.
1. Warm up and stop the engine.

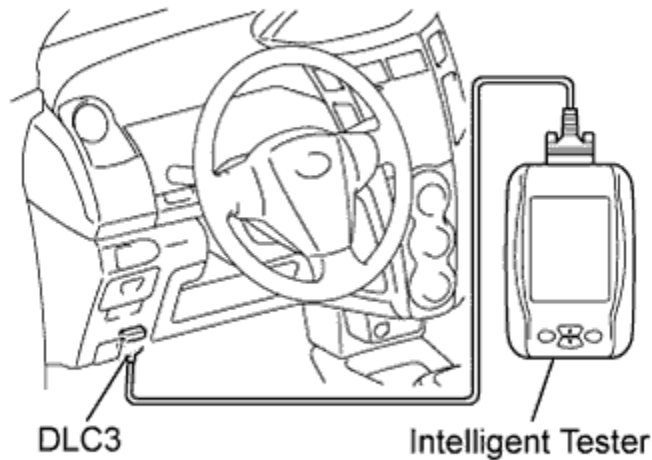

2. When using the intelligent tester:

1. Connect the intelligent tester to the DLC3.
2. Turn the Ignition Switch on (IG).
3. Select the following menu items:
Powertrain / Engine and ECT / Active Test / TE1 (TC) / ON.

HINT:

Refer to the intelligent tester operator's manual for further information regarding the selection of Active Test.

4. Inspect the ignition timing during idling.

Ignition timing:

8 to 12° BTDC

5. Select the following menu items:
TE1 (TC) / OFF
6. Turn the Ignition Switch off.
7. Disconnect the intelligent tester from the DLC3.

3. When not using the intelligent tester:
 1. Remove the air cleaner cap sub-assembly ().

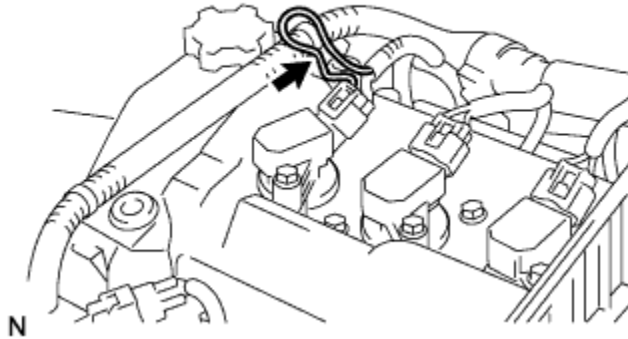

2. Install the tester terminal of a timing light onto the position shown in the illustration.

NOTICE:

- Use a timing light that detects the first signal.
- Wrap the wire harness with tape after checking.

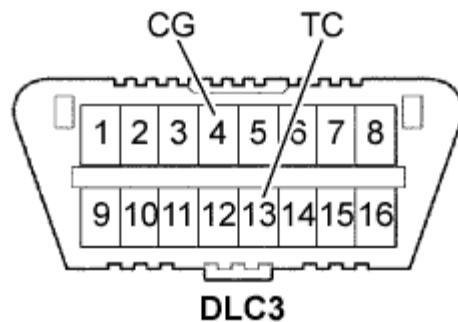

3. Using SST, connect terminals 13 (TC) and 4 (CG) of the DLC3.

SST
09843-18040

NOTICE:

Check the terminal numbers before connecting them. Connecting the wrong terminals could damage the engine.

4. Turn the Ignition Switch on (IG).
5. Inspect the ignition timing during idling.

Ignition timing:

0 to 15° BTDC

HINT:

Run the engine speed at 1,000 to 1,300 rpm for 5 seconds, then check that the engine speed returns to the idling speed.

6. Disconnect terminals 13 (TC) and 4 (CG) of the DCL3.
7. Turn the Ignition Switch off.
8. Remove the timing light.
9. Install the air cleaner cap sub-assembly ().

| |
|----------------------------------|
| 113. INSPECT ENGINE IDLING SPEED |
|----------------------------------|

NOTICE:

- Turn all the electrical systems and the A/C off.
 - Inspect the engine idling speed with the cooling fan off.
 - When checking the idling speed, shift the transmission to the neutral position.
1. Warm up and stop the engine.

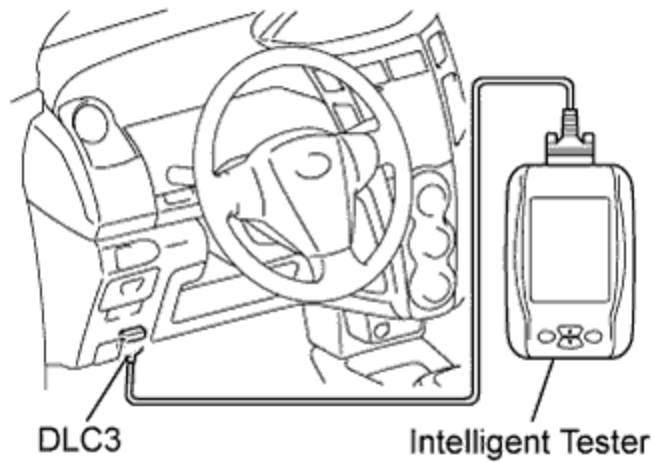

2. When using the intelligent tester:

1. Connect the intelligent tester to the DLC3.
2. Turn the Ignition Switch on (IG).
3. Select the following menu items:
Powertrain / Engine and ECT / Data List / Engine SPD.

HINT:

Refer to the intelligent tester operator's manual for further information regarding the selection of Data List.

4. Inspect the engine idling speed.

Idling speed:

730 to 830 rpm

5. Turn the Ignition Switch off.
6. Disconnect the intelligent tester from the DCL3.

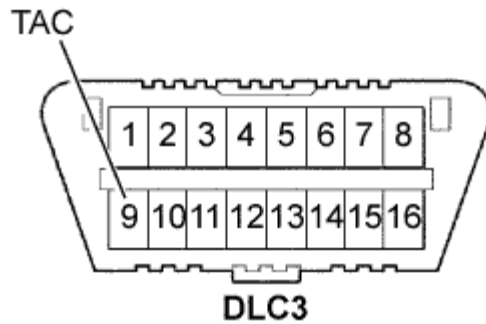

3. When not using an intelligent tester:

1. Install SST to terminal 9 (TAC) of the DLC3, then connect a tachometer.

SST
09843-18040

NOTICE:

Check the terminal numbers before connecting them. Connecting the wrong terminals could damage the engine.

2. Turn the Ignition Switch on (IG).
3. Inspect the engine idling speed.

Idling speed:
730 to 830 rpm

4. Turn the Ignition Switch off.
5. Disconnect the tachometer.
6. Remove SST from terminal 9 (TAC).

114. INSPECT CO/HC

HINT:

The ECM controls the concentration of CO/HC in the emission gas.

1. Start the engine.
2. Run the engine at 2,500 rpm for approximately 180 seconds.
3. Insert the CO/HC meter testing probe at least 40 cm (1.3 ft) into the tailpipe during idling.

4. Check the CO/HC concentration during idling and when running at 2,500 rpm.

Standard:

CO concentration:

0.2 % or less

HC concentration:

70 ppm or less

If the CO/HC concentration does not comply with the regulations, troubleshoot in the order given below.

- Check the heated oxygen sensor operation (and/or).
- See the table below for possible causes, then inspect the applicable parts and repair them if necessary.

| CO | HC | Problems | Causes |
|--------|------|--|---|
| Normal | High | Rough idling | 3. Faulty ignition: <ul style="list-style-type: none"> • Fouled, shorted or improperly gapped plugs 4. Incorrect valve clearance 5. Leakage from intake and exhaust valves 6. Leakage from cylinders |
| Low | High | Rough idling (Fluctuating HC reading) | 7. Lean mixture causing misfire 8. Faulty SFI systems: <ul style="list-style-type: none"> • Faulty pressure regulator • Faulty engine coolant temperature sensor • Faulty mass air flow meter • Faulty ECM • Faulty injectors • Faulty throttle body |
| High | High | Rough idling (Black smoke from exhaust) | 9. Faulty SFI systems: <ul style="list-style-type: none"> • Faulty pressure regulator • Faulty engine coolant temperature sensor • Faulty mass air flow meter • Faulty ECM |

| | | | |
|--|--|--|---|
| | | | <ul style="list-style-type: none">• Faulty injectors• Faulty throttle body |
|--|--|--|---|

115. INSPECT AND ADJUST FRONT WHEEL ALIGNMENT (for TMC Made)

()

116. INSPECT AND ADJUST FRONT WHEEL ALIGNMENT (for TMMF Made)

()

117. INSTALL ENGINE UNDER COVER RH

118. INSTALL ENGINE UNDER COVER LH

119. INSTALL FRONT SPOILER COVER (w/ Front Spoiler Cover)

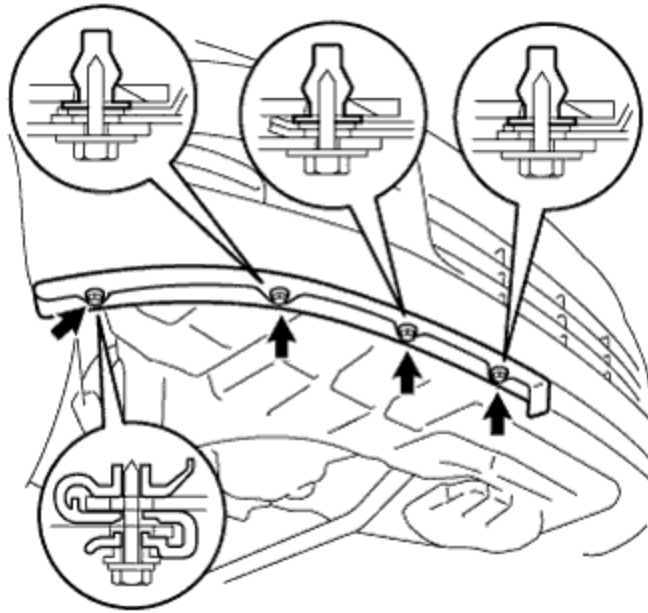

T

1. Install the front spoiler cover with the 4 screws.

120. INSTALL FRONT SPOILER COVER LH (w/ Front Spoiler Cover LH)

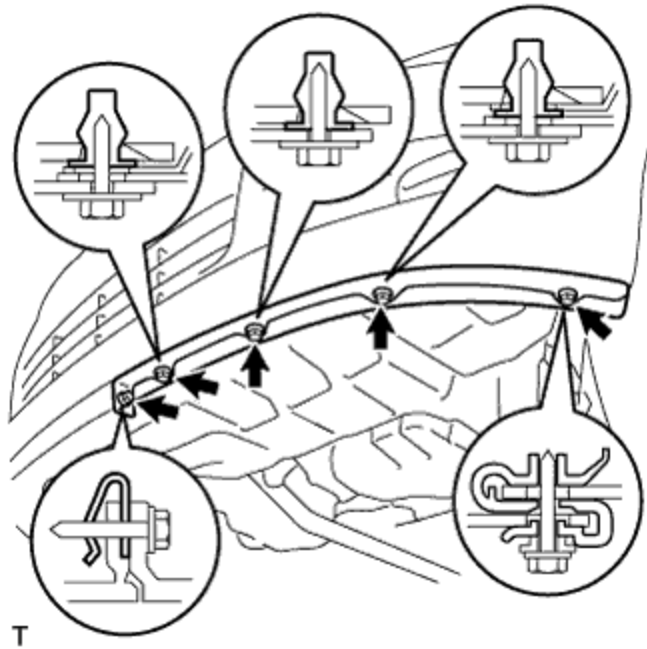

T

1. Install the front spoiler cover with the 5 screws.

ENGINE UNIT > COMPONENTS

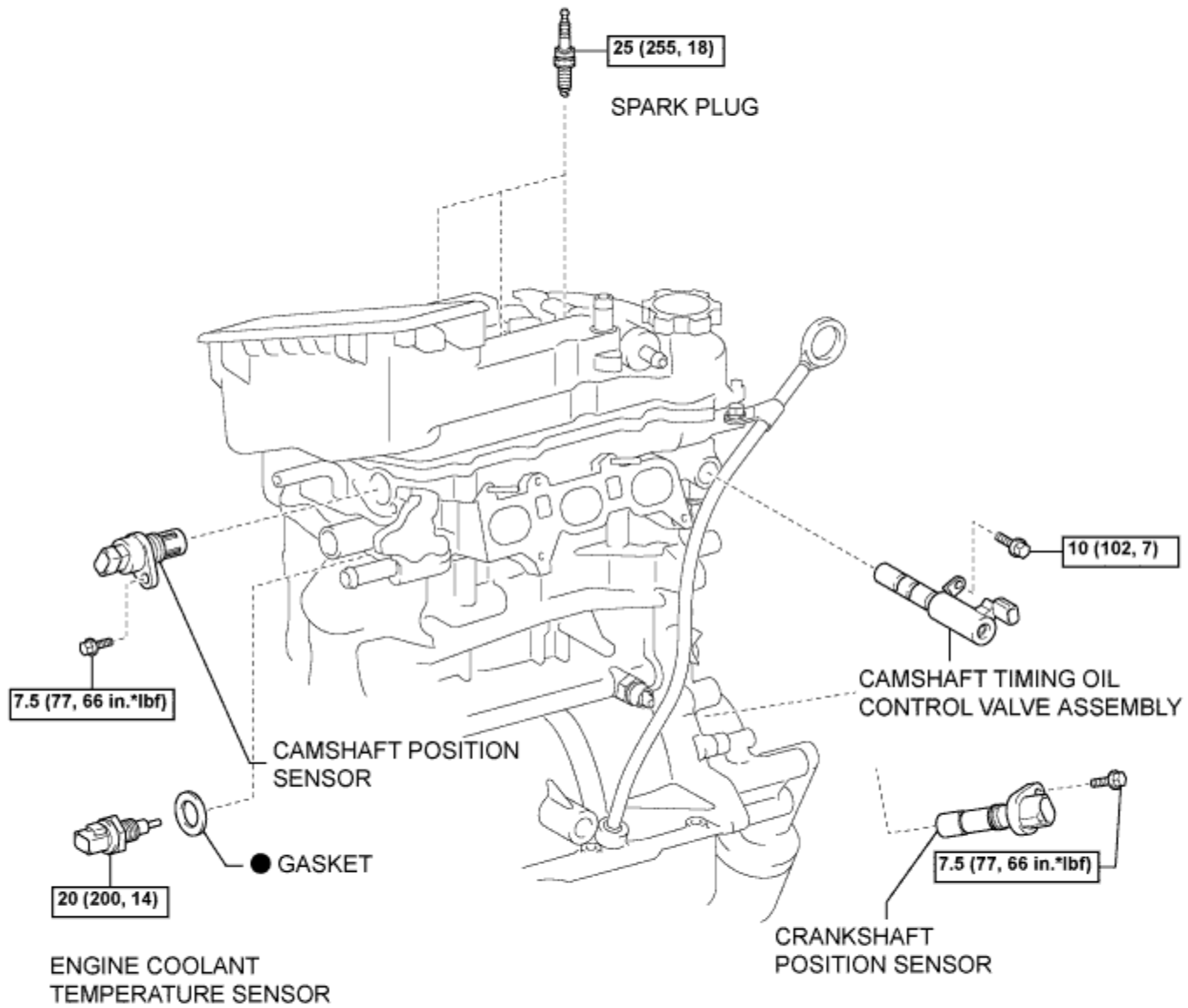

N*m (kgf*cm, ft*lbf) : Specified torque

● Non-reusable part

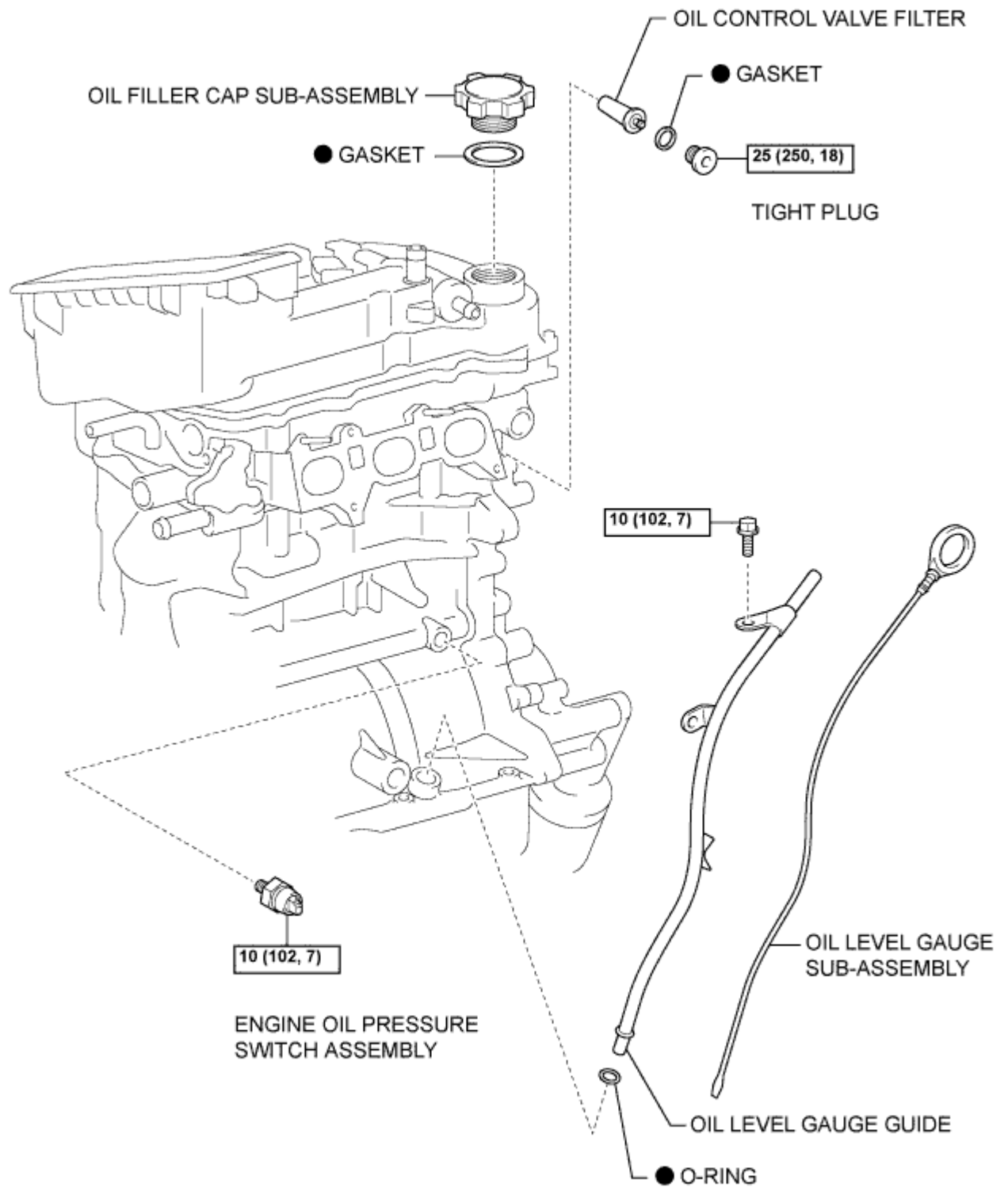

N*m (kgf*cm, ft*lbf) : Specified torque

● Non-reusable part

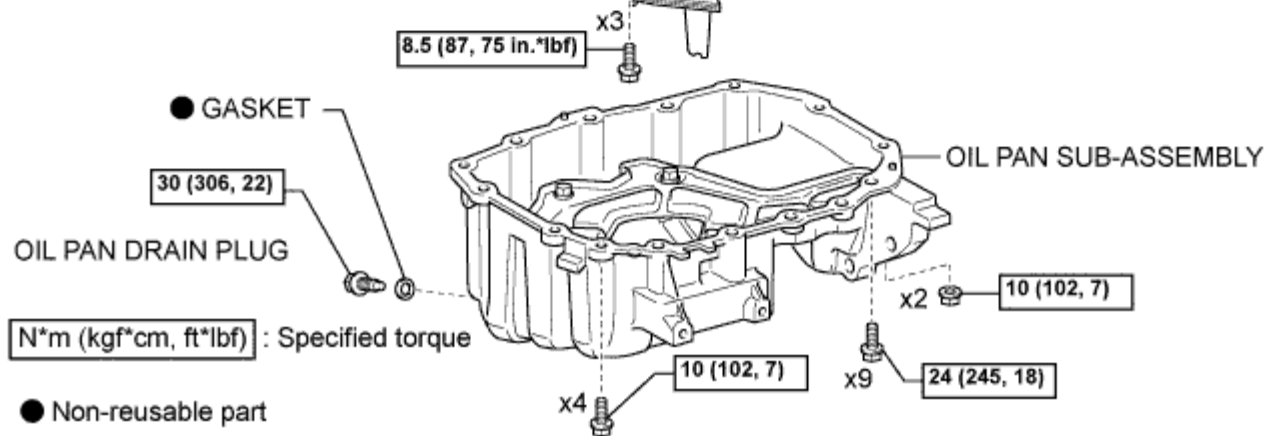
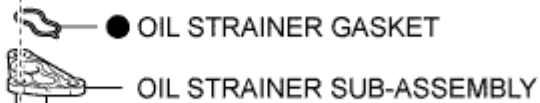
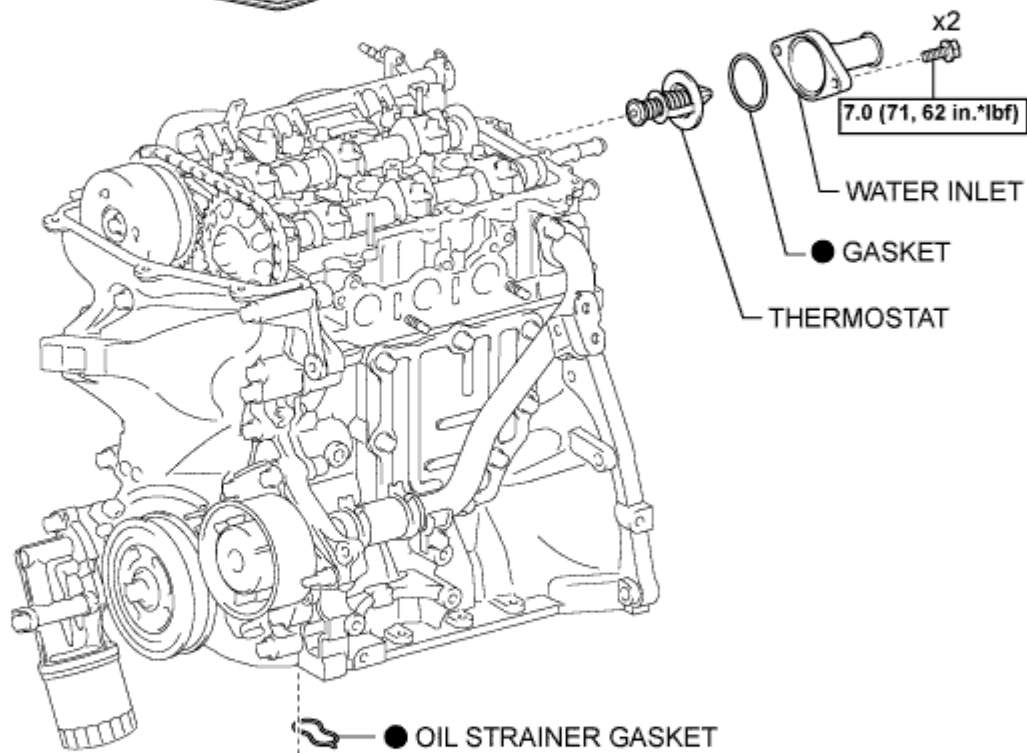
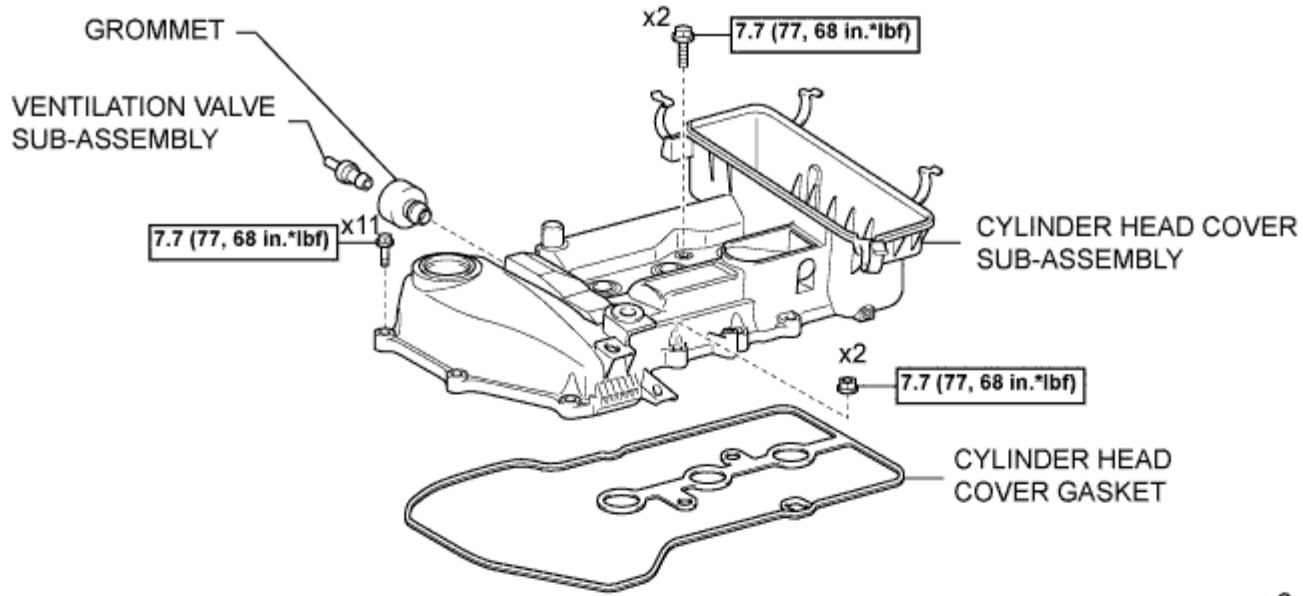

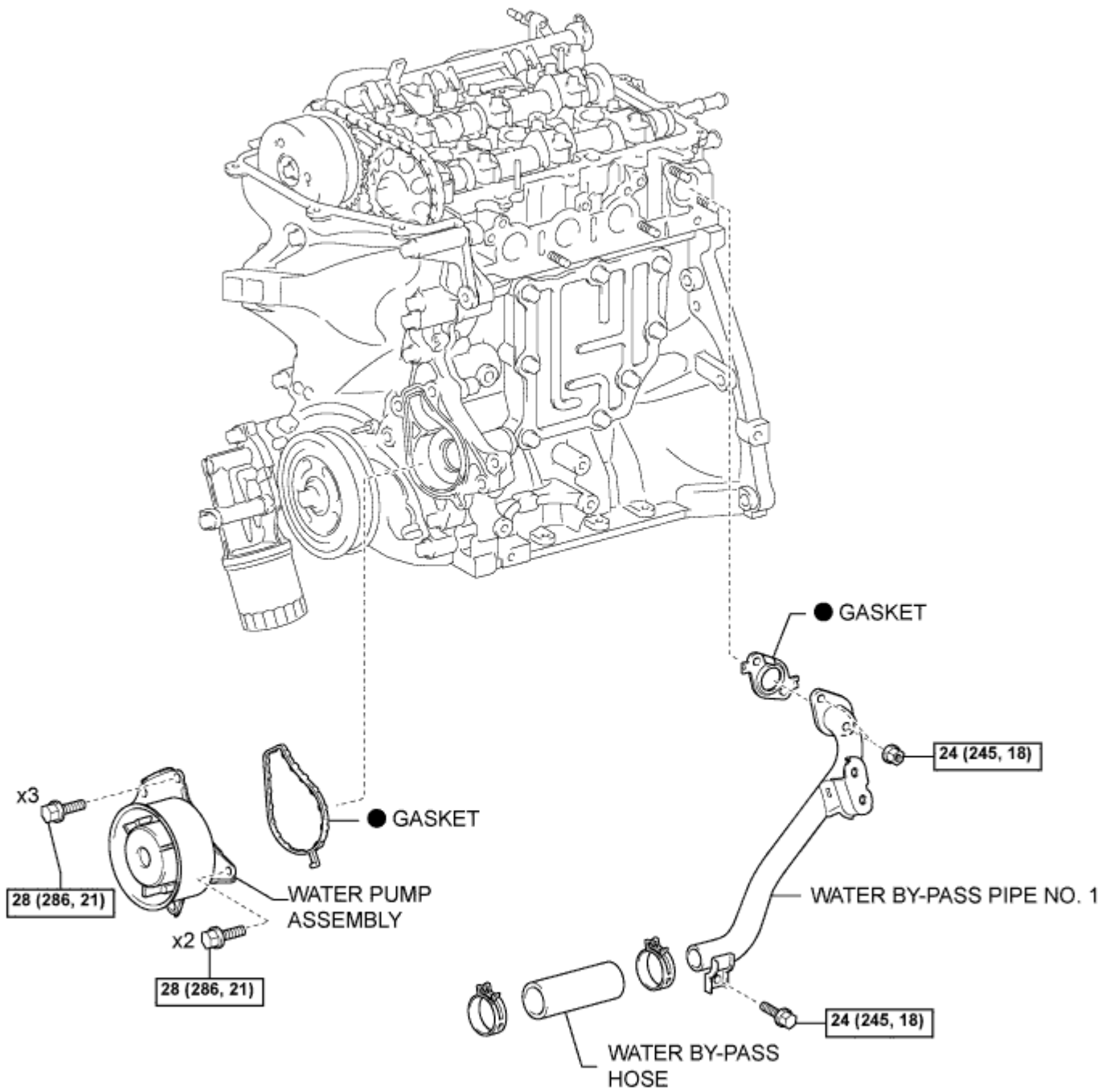

N*m (kgf*cm, ft*lbf) : Specified torque

● Non-reusable part

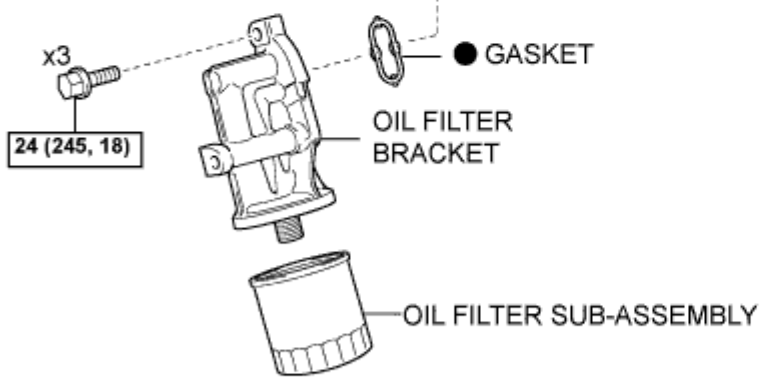
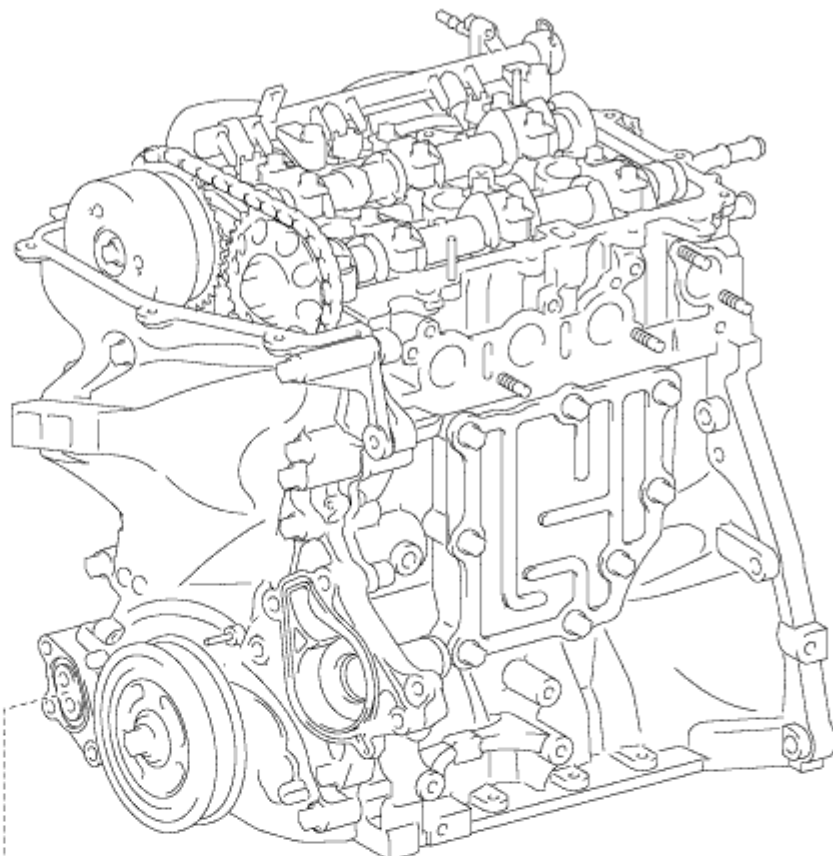

N*m (kgf*cm, ft*lbf) : Specified torque

● Non-reusable part

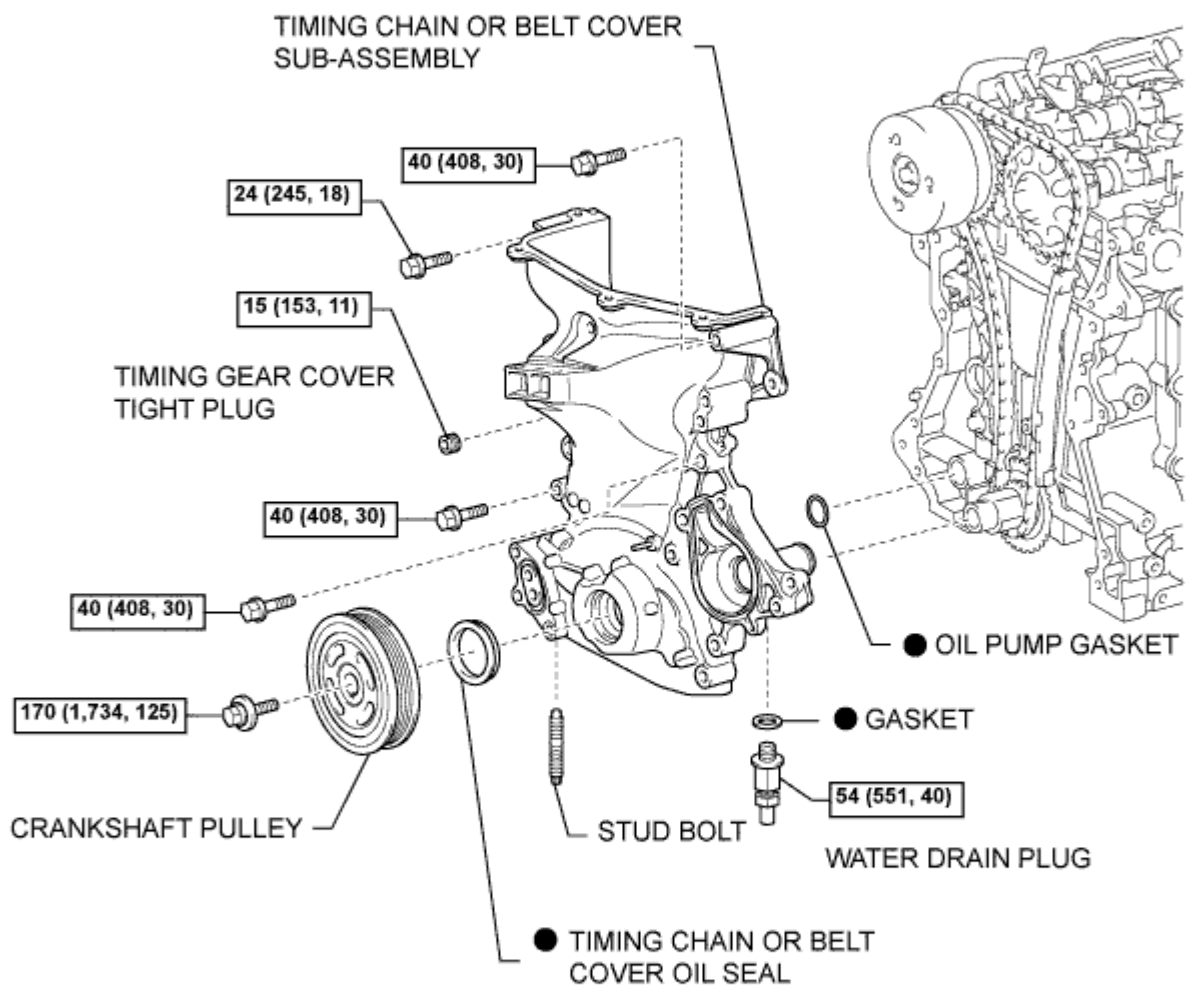

N*m (kgf*cm, ft*lbf) : Specified torque

● Non-reusable part

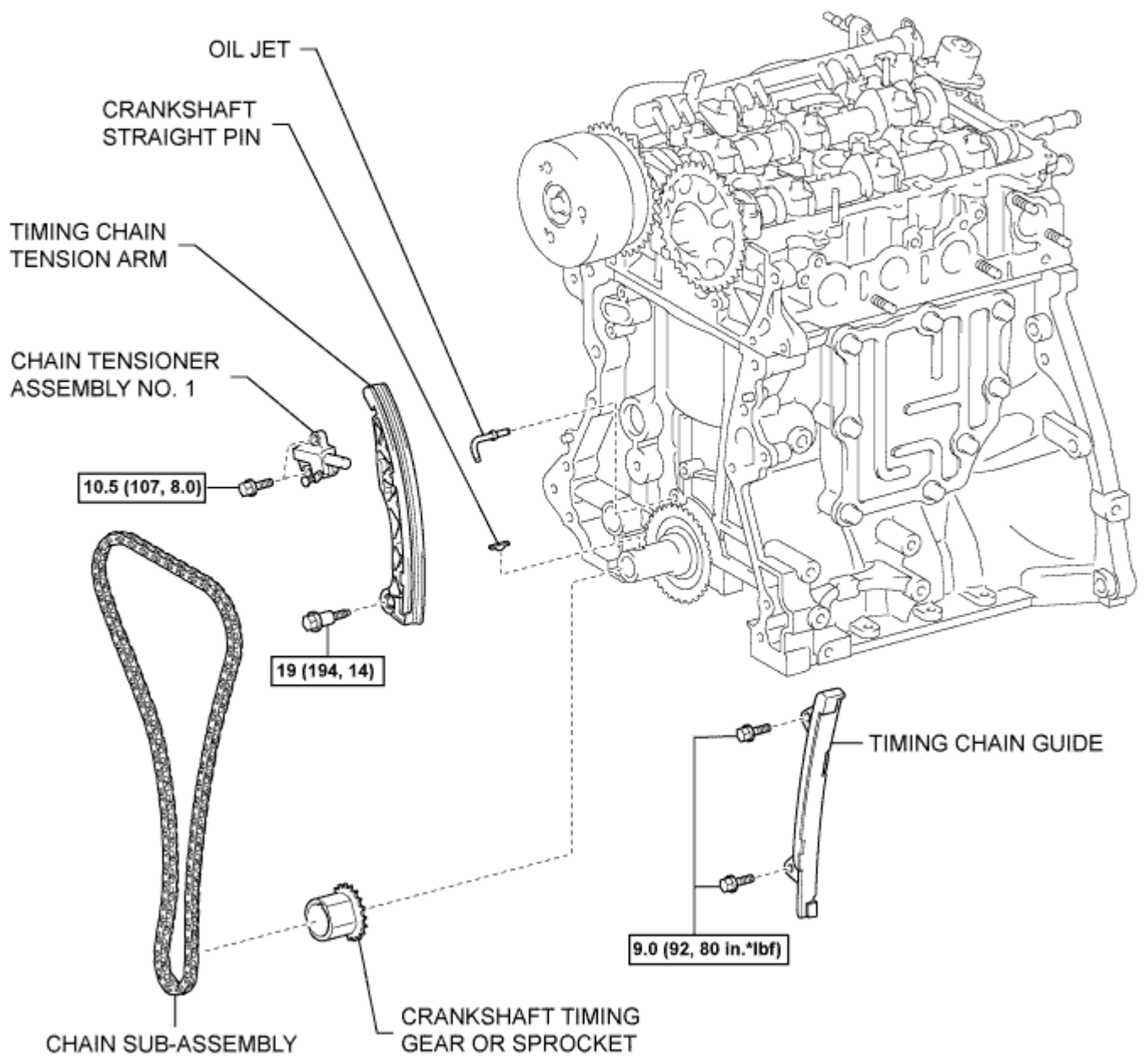

N*m (kgf*cm, ft*lbf) : Specified torque

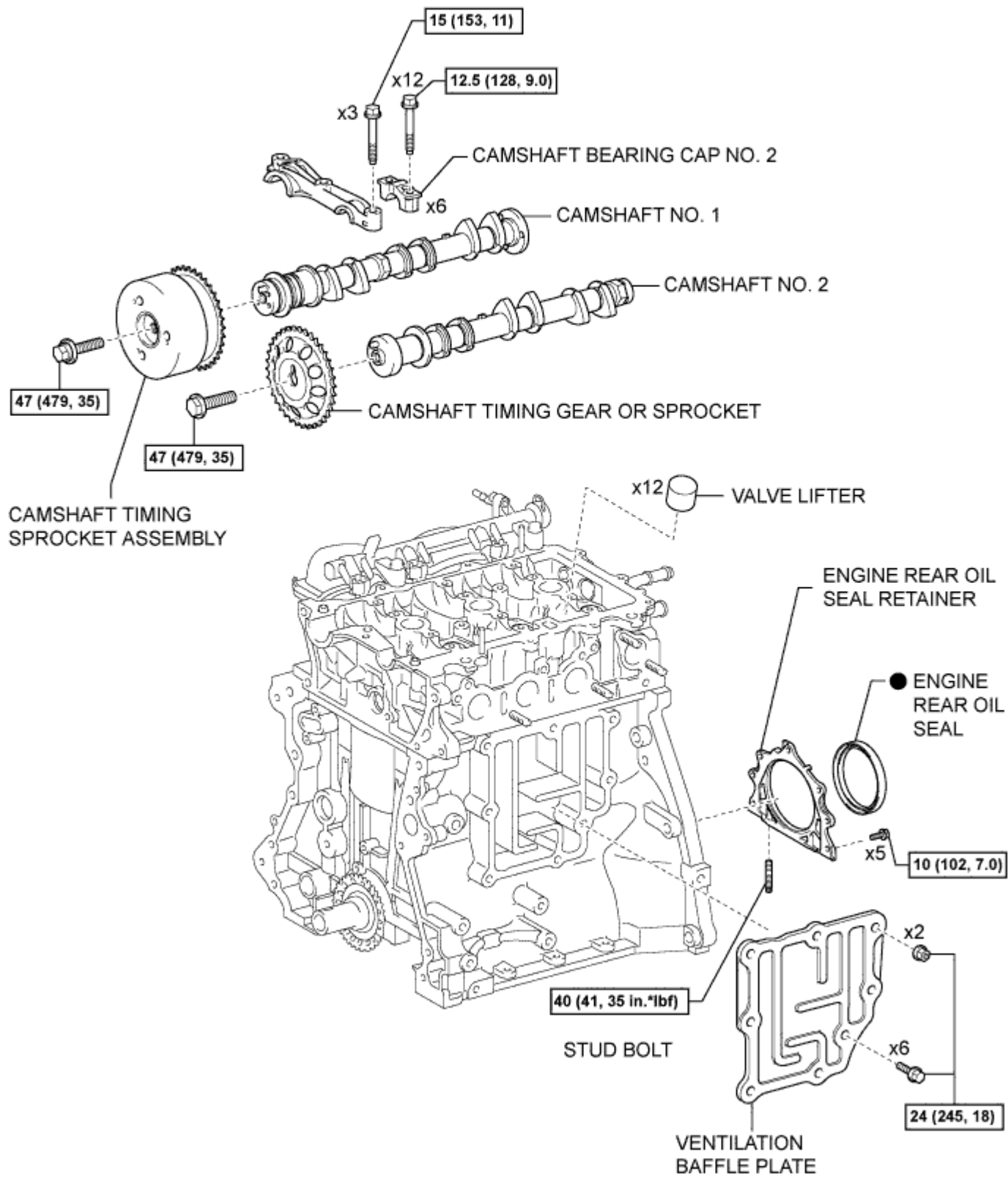

N*m (kgf*cm, ft*lbf) : Specified torque

● Non-reusable part

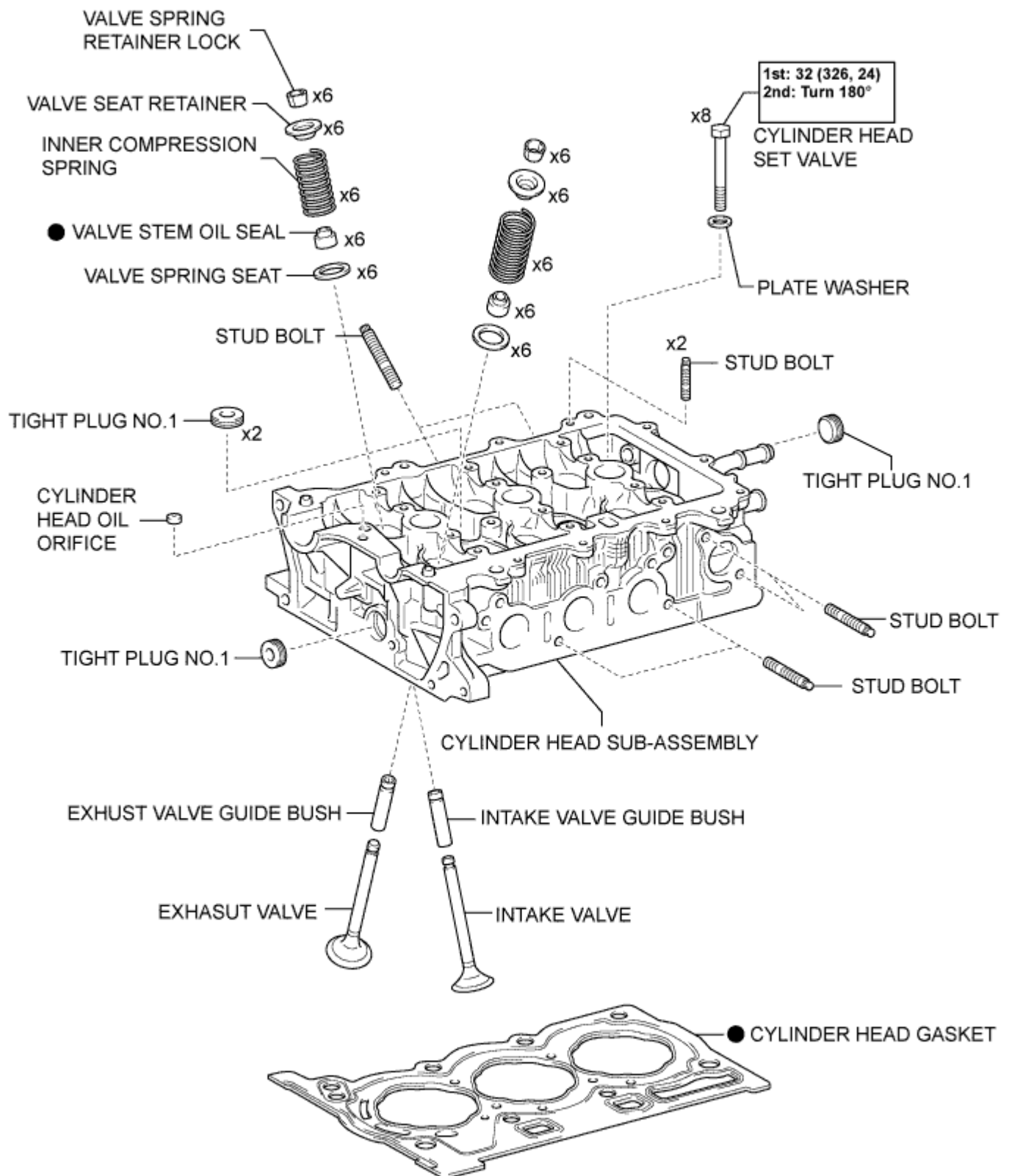

N*m (kgf*cm, ft.*lbf) : Specified torque

● Non-reusable part

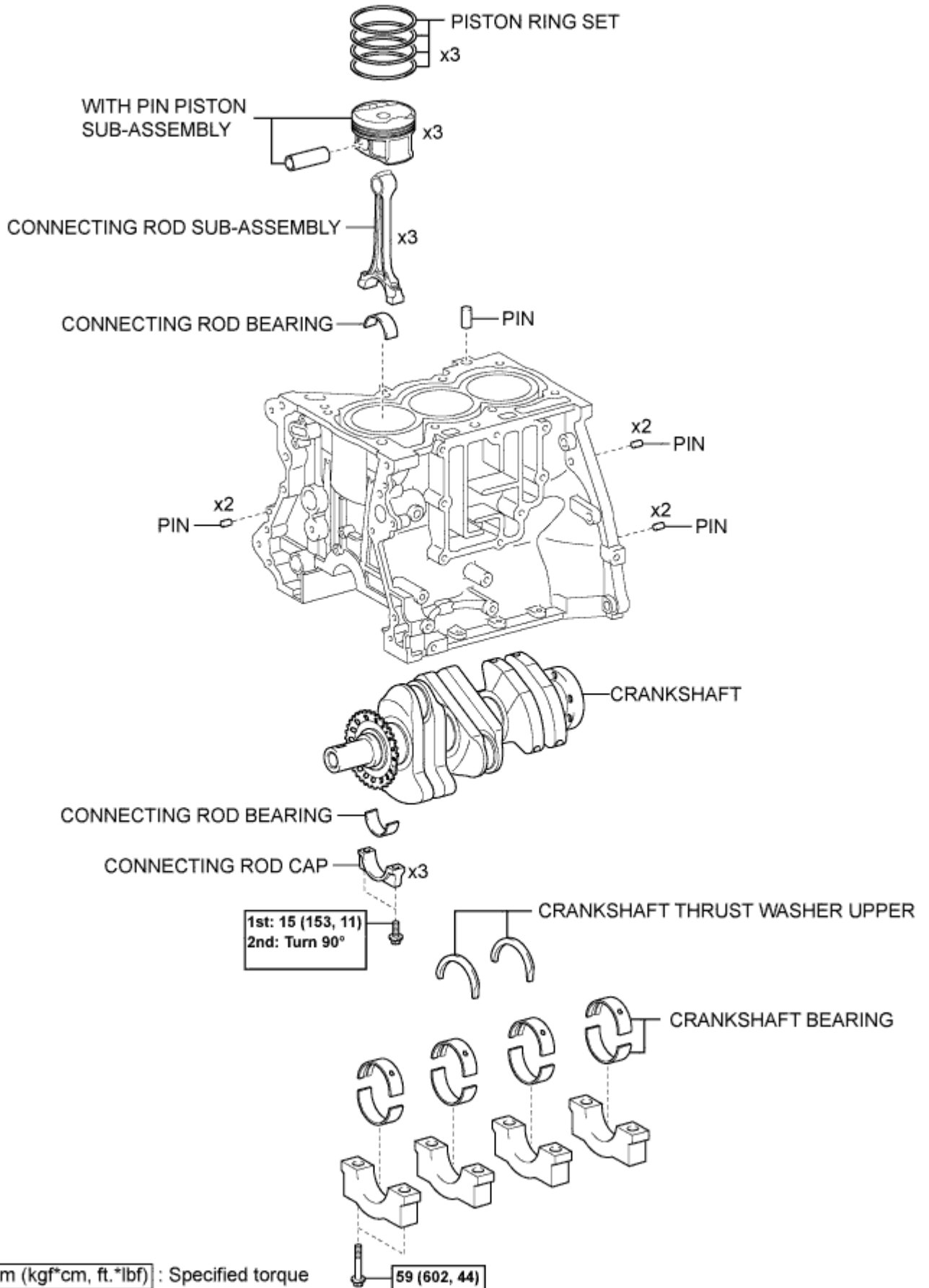

ENGINE UNIT > DISASSEMBLY

CAUTION:

- Prolonged and repeated contact with engine oil will result in the removal of natural oils from the skin, leading to dryness, irritation and dermatitis, used engine oil contains potentially harmful contaminants which may cause skin cancer.
- Take precautions when replacing engine oil to minimize the risk of your skin making contact with used engine oil. Wear protective clothing and gloves that cannot be penetrated by oil. Wash skin with soap and water, or use water-less hand cleaner, to remove any used engine oil thoroughly. Do not use gasoline, thinner, or solvents.
- Dispose of used oil and used oil filters at designated disposal sites in order to preserve the environment.

1. REMOVE ENGINE HANGERS

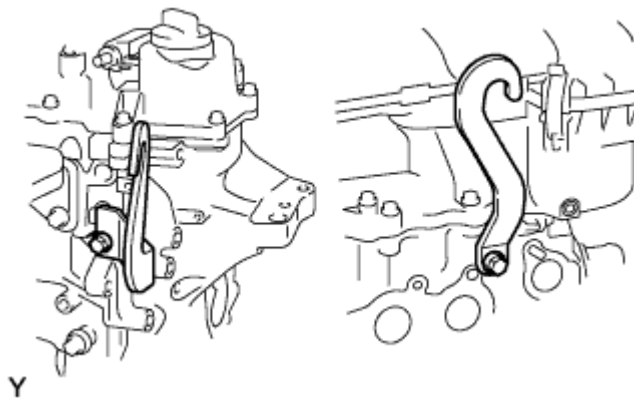

1. Remove the 2 bolts and remove the 2 engine hangers.

2. REMOVE SPARK PLUG

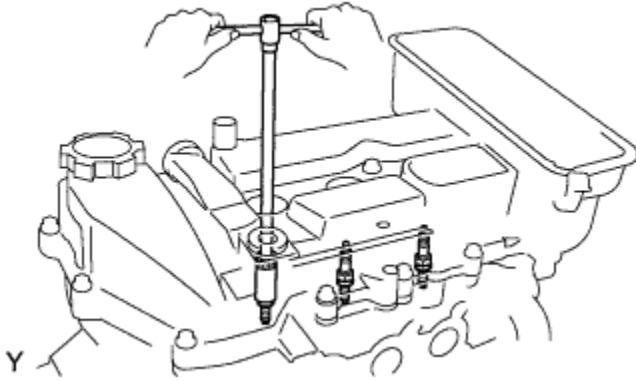

1. Remove the 3 spark plugs.

3. REMOVE CAMSHAFT POSITION SENSOR

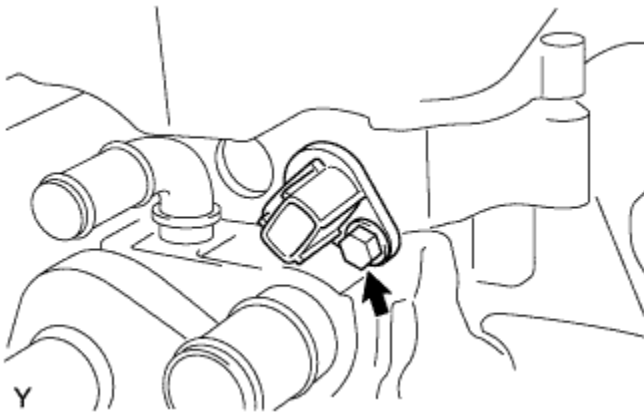

1. Remove the bolt and remove the camshaft position sensor.

4. REMOVE ENGINE COOLANT TEMPERATURE SENSOR

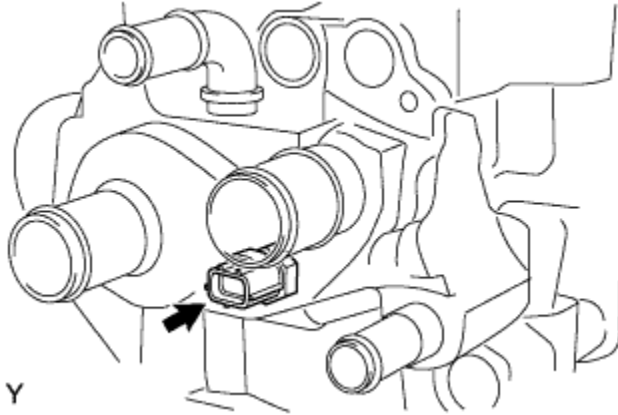

1. Remove the engine coolant temperature sensor.

5. REMOVE CAMSHAFT TIMING OIL CONTROL VALVE ASSEMBLY

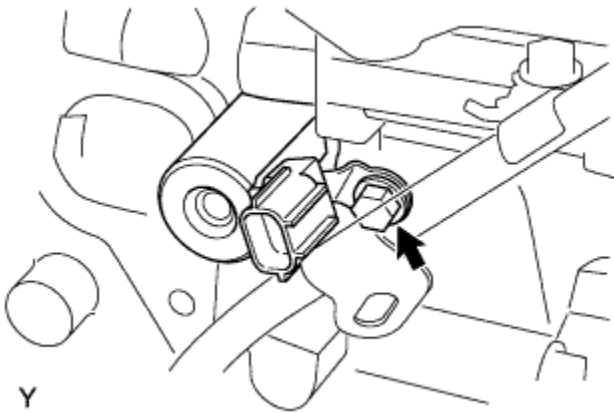

1. Remove the bolt and remove the camshaft timing oil control valve.

6. REMOVE CRANKSHAFT POSITION SENSOR

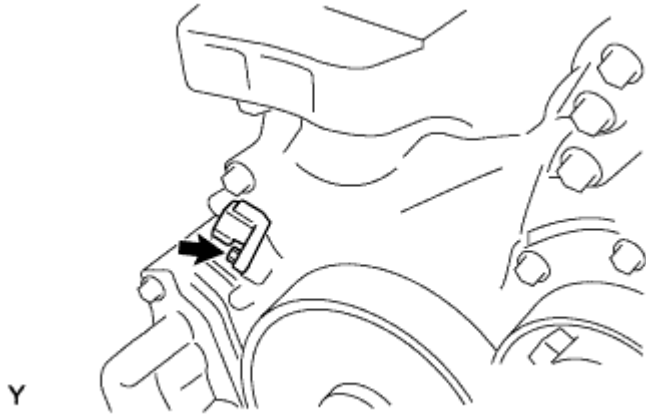

1. Remove the bolt and remove the crankshaft position sensor.

7. REMOVE OIL LEVEL GAUGE SUB-ASSEMBLY

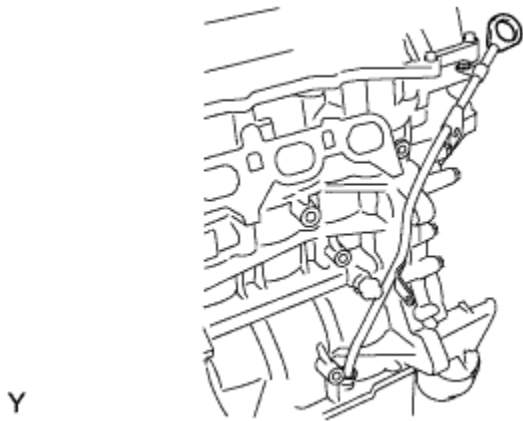

8. REMOVE OIL LEVEL GAUGE GUIDE

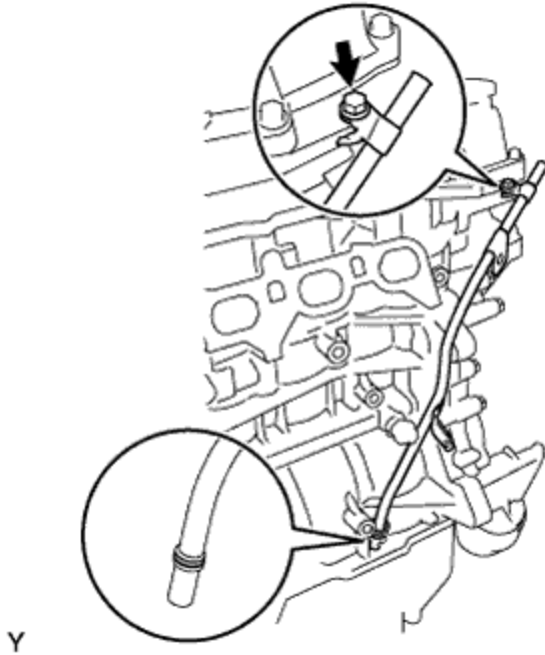

1. Remove the bolt and remove the level gauge guide with the O-ring.

9. REMOVE ENGINE OIL PRESSURE SWITCH ASSEMBLY

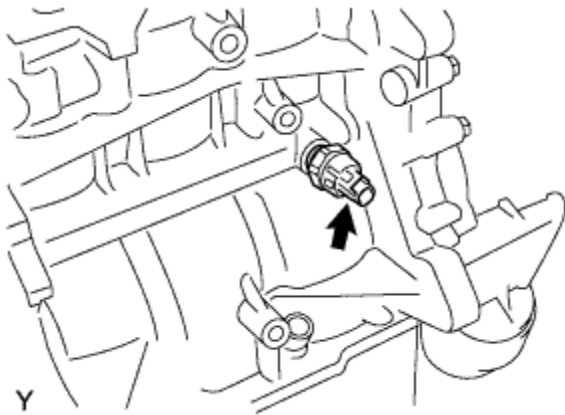

1. Using a 24 mm deep socket wrench, remove the oil pressure switch.

10. REMOVE OIL CONTROL VALVE FILTER

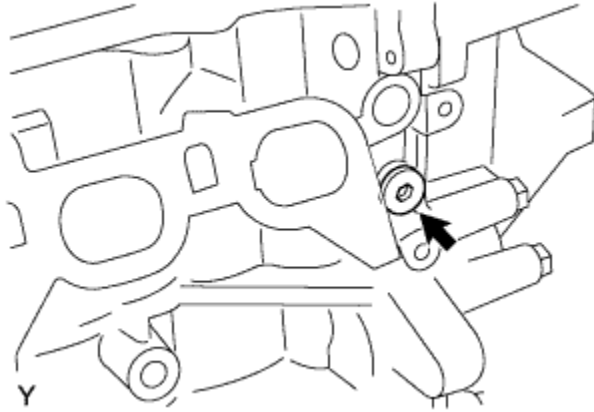

1. Remove the tight plug shown in the illustration.

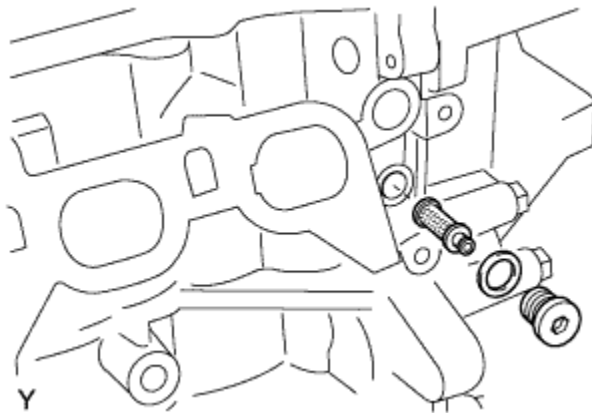

2. Remove the oil control valve filter and gasket.

11. REMOVE OIL FILLER CAP SUB-ASSEMBLY

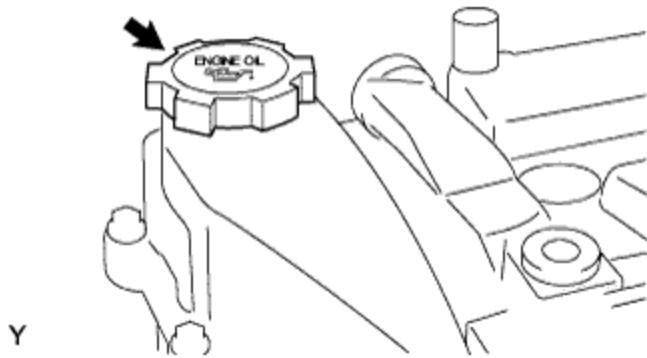

1. Remove the oil filler cap.

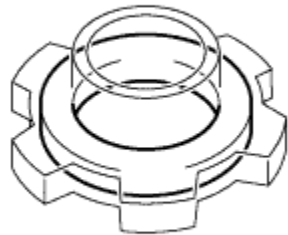

Y

2. Using a screwdriver, remove the gasket from the oil filler cap.

12. REMOVE CYLINDER HEAD COVER SUB-ASSEMBLY

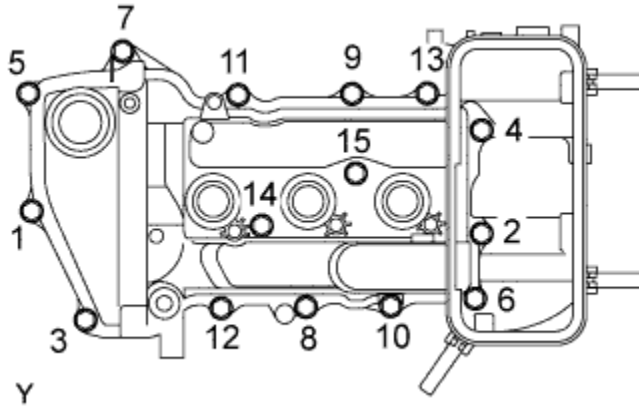

1. Remove the 13 bolts and 2 nuts in the order shown in the illustration.

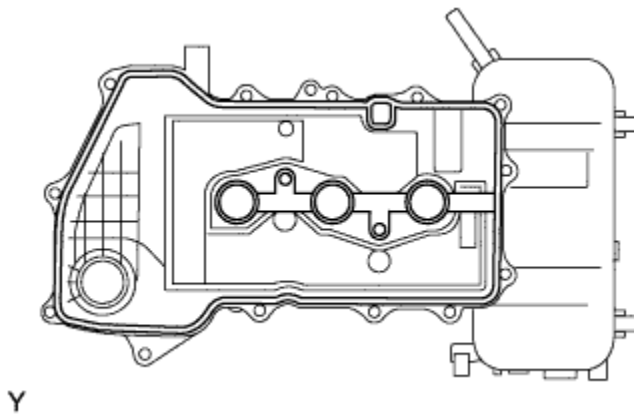

2. Remove the cylinder head cover with the gasket.

13. REMOVE VENTILATION VALVE SUB-ASSEMBLY

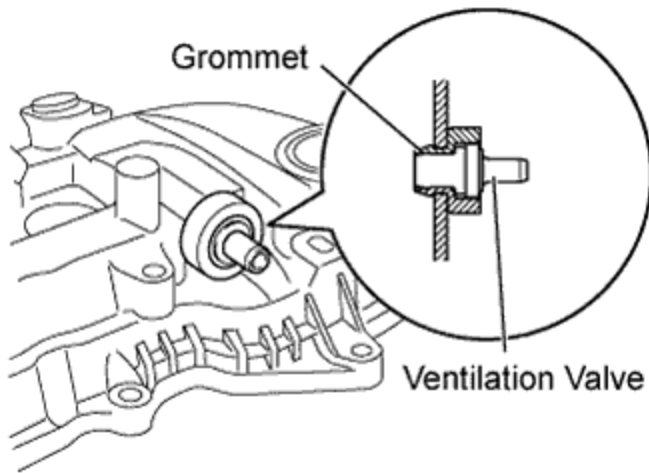

Y

1. Remove the ventilation valve.
2. Remove the grommet.

14. REMOVE OIL PAN DRAIN PLUG

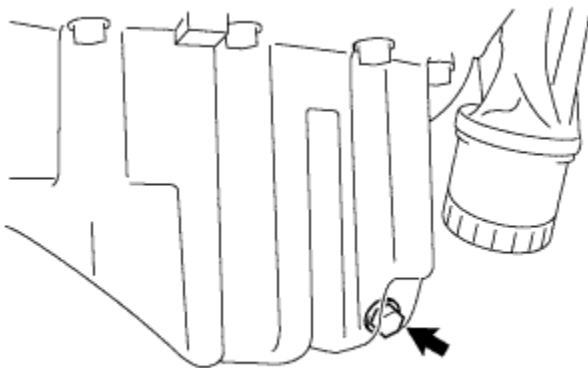

Y

1. Remove the drain plug.
2. Remove the gasket.

15. REMOVE OIL PAN SUB-ASSEMBLY

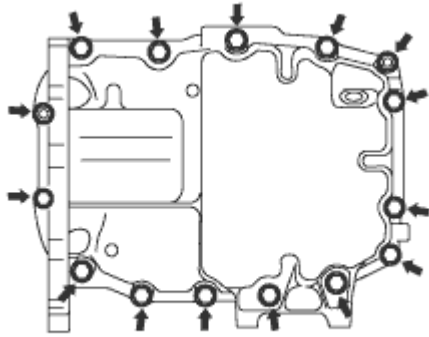

Y

1. Remove the 13 bolts and 2 nuts.

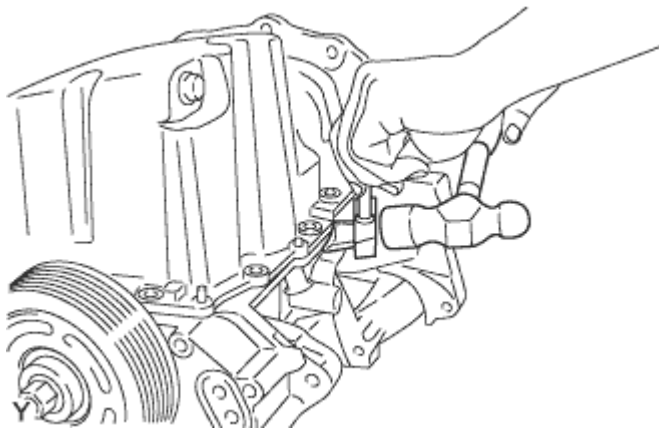

2. Using SST, remove the oil pan.

SST

09032-00100

NOTICE:

Do not damage the flange of the oil pan.

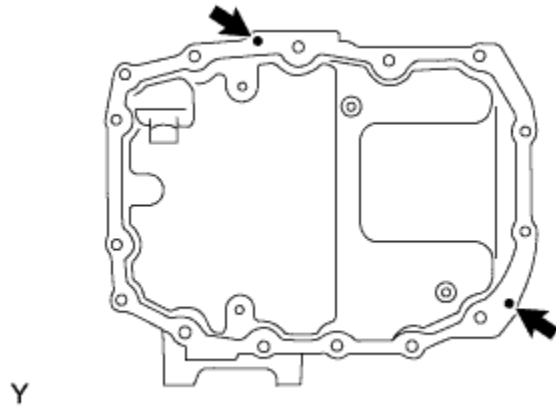

3. Remove the 2 straight pins from the oil pan.

16. REMOVE OIL STRAINER SUB-ASSEMBLY

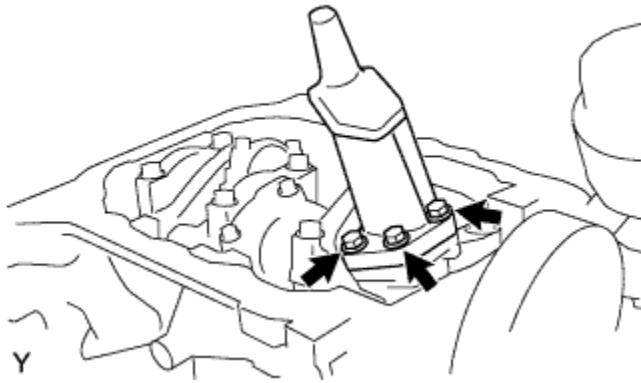

1. Remove the 3 bolts and remove the oil strainer.

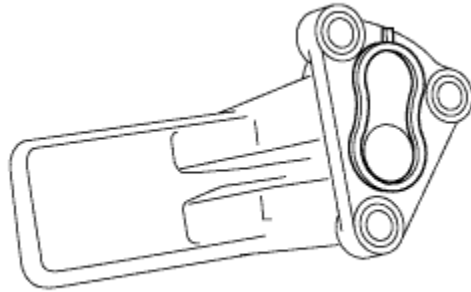

Y

2. Remove the gasket.

17. REMOVE WATER INLET

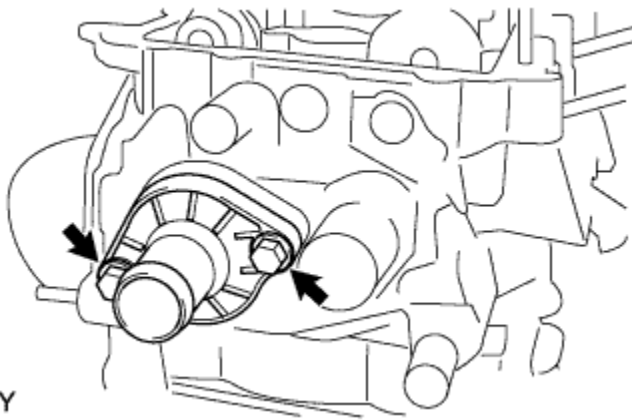

Y

1. Remove the 2 bolts and remove the water inlet.

18. REMOVE THERMOSTAT

1. Remove the thermostat with gasket from the water inlet.

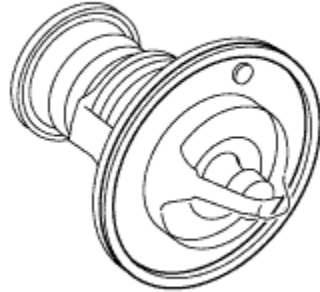

Y

2. Remove the gasket from the thermostat.

19. REMOVE WATER BY-PASS PIPE NO. 1

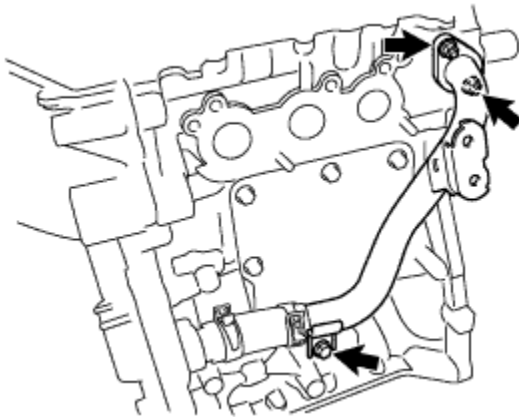

1. Remove the bolt and 2 nuts, and separate the water by-pass pipe from the cylinder head and cylinder block.

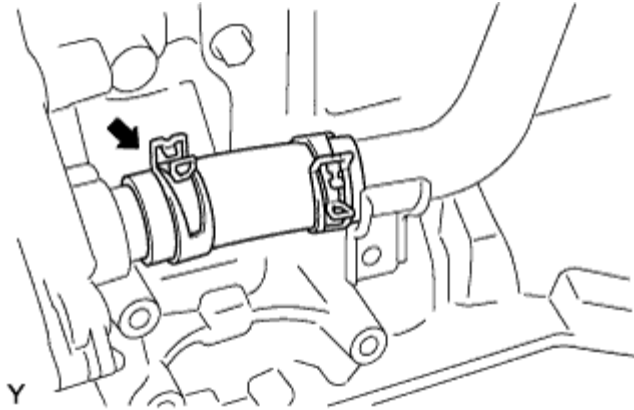

2. Remove the clamp and remove the water by-pass pipe.

20. REMOVE WATER BY-PASS HOSE

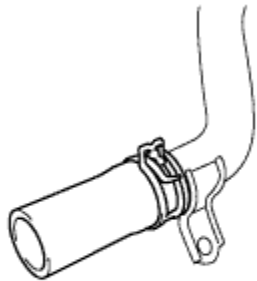

1. Remove the clamp, and remove the water by-pass hose from the water by-pass pipe.

21. REMOVE WATER PUMP ASSEMBLY

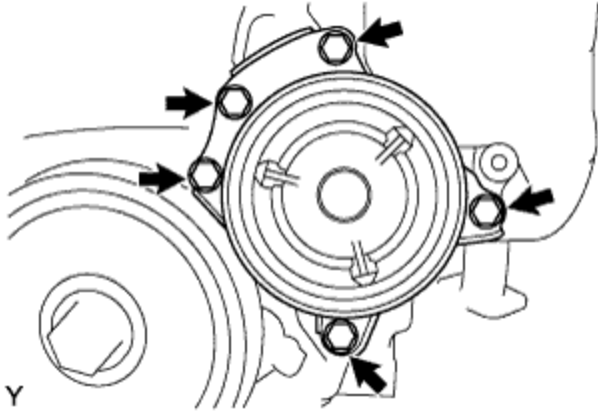

1. Remove the 5 bolts and remove the water pump.

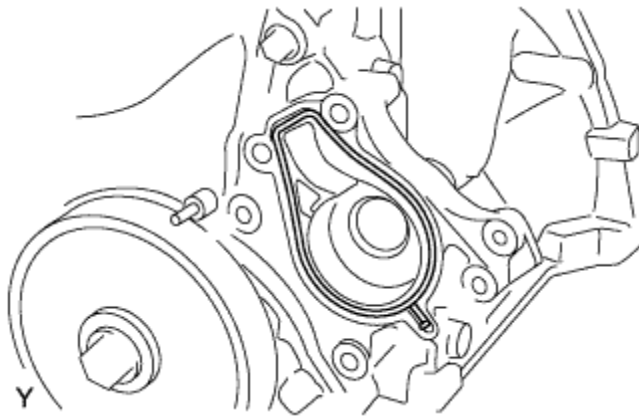

2. Remove the gasket.

22. REMOVE OIL FILTER SUB-ASSEMBLY

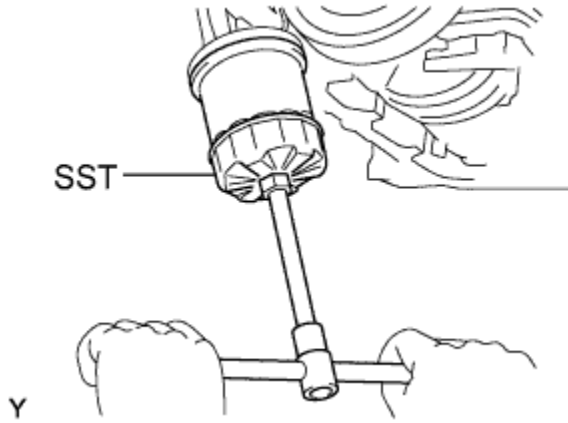

1. Using SST, remove the oil filter.

SST
09228-06501

23. REMOVE OIL FILTER BRACKET

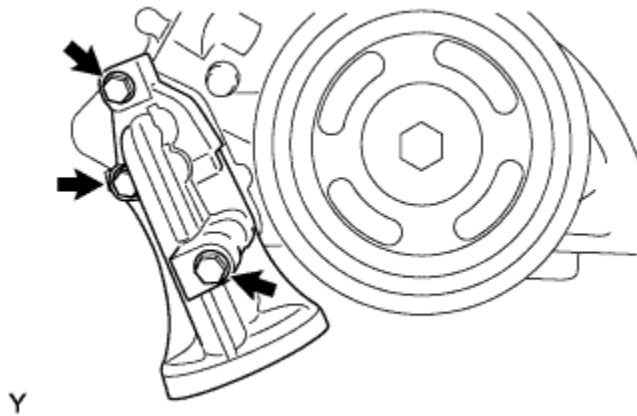

1. Remove the 3 bolts and remove the oil filter bracket.

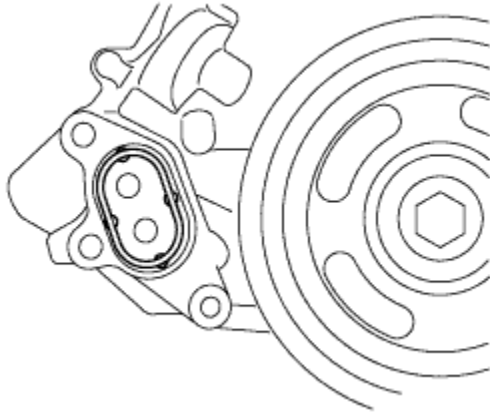

Y

2. Remove the gasket.

24. REMOVE TIMING GEAR COVER TIGHT PLUG

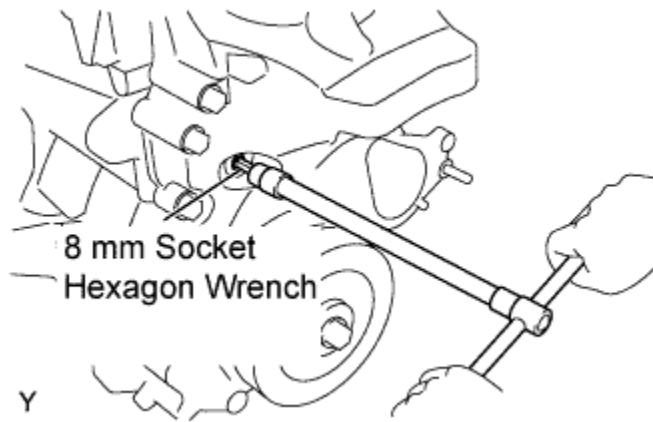

Y

1. Using an 8 mm socket hexagon wrench, remove the tight plug.

25. SET NO. 1 CYLINDER TO TDC/COMPRESSION

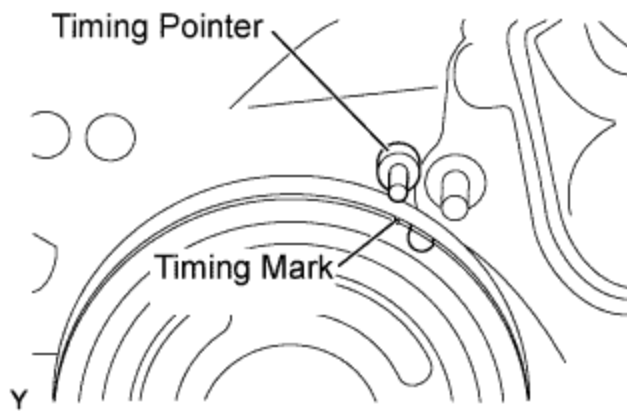
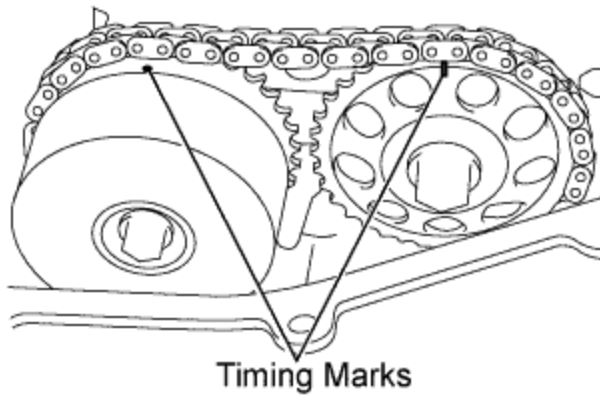

1. Turn the crankshaft pulley clockwise to align the timing mark on the pulley with the timing pointer of the timing chain cover.

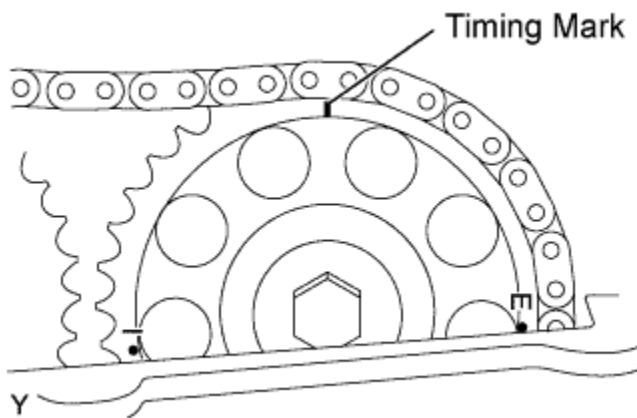

2. Make sure that the timing mark of the camshaft sprocket is at the top.

26. REMOVE CRANKSHAFT PULLEY

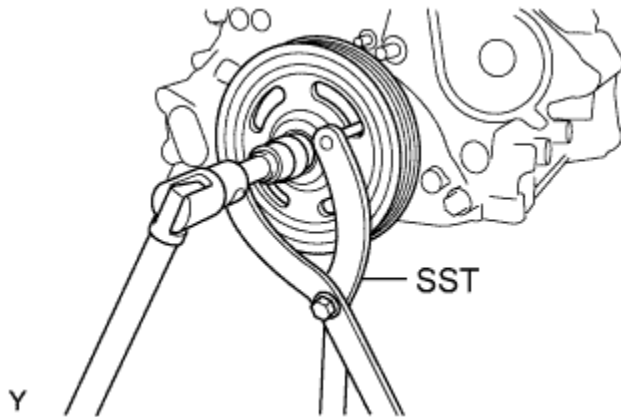

1. Using SST, remove the crankshaft pulley bolt.

SST
09960-10010 (09962-01000, 09963-01000)

2. Remove the crankshaft pulley.

27. REMOVE TIMING CHAIN OR BELT COVER SUB-ASSEMBLY

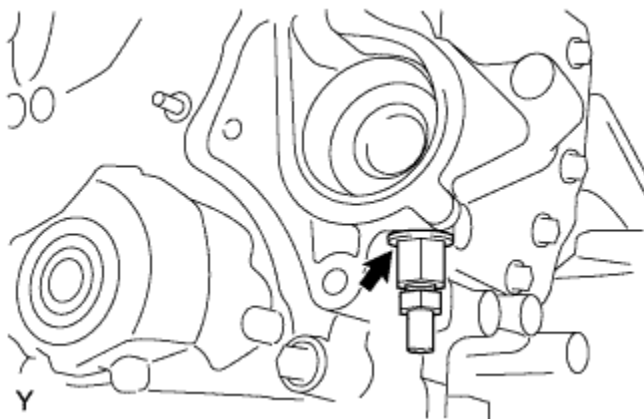

1. Remove the water drain plug and gasket.

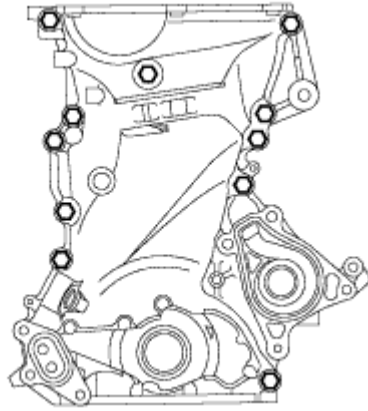

2. Remove the 11 bolts.

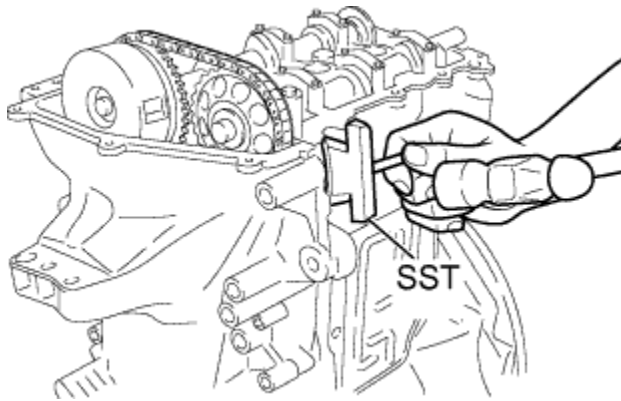

3. Using SST, remove the timing chain cover.

SST

09032-00100

NOTICE:

Do not damage the contact surfaces of the cylinder head, cylinder block and timing chain cover.

HINT:

Wrap the screwdriver tip in protective tape before use.

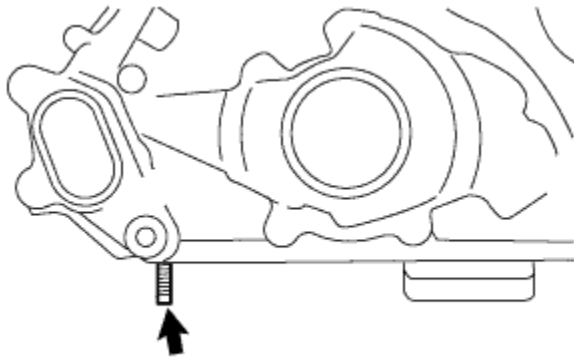

Y

4. Remove the stud bolt.

28. REMOVE TIMING CHAIN OR BELT COVER OIL SEAL

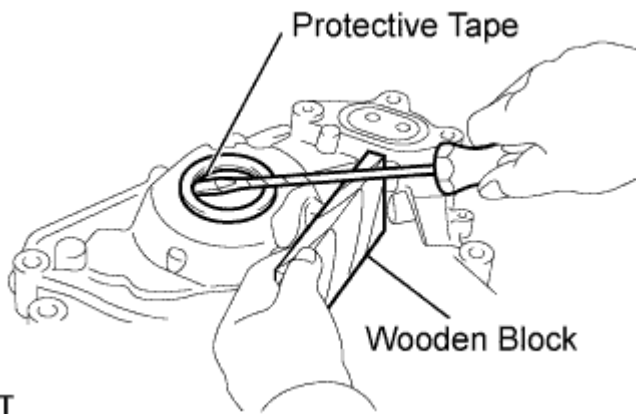

T

1. Using a screwdriver with its tip wrapped in protective tape, pry out the oil seal.

29. REMOVE OIL PUMP GASKET

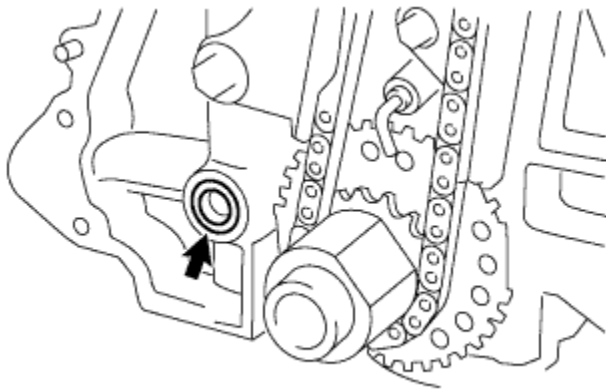

Y

1. Remove the oil pump gasket from the cylinder block.

30. REMOVE CHAIN TENSIONER ASSEMBLY NO. 1

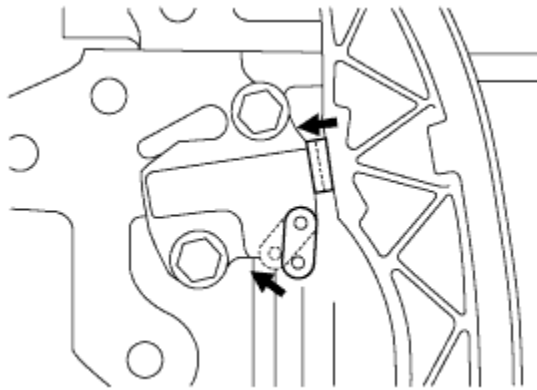

C

1. Turn the stopper plate of the chain tensioner clockwise and push in the plunger with the lock released.

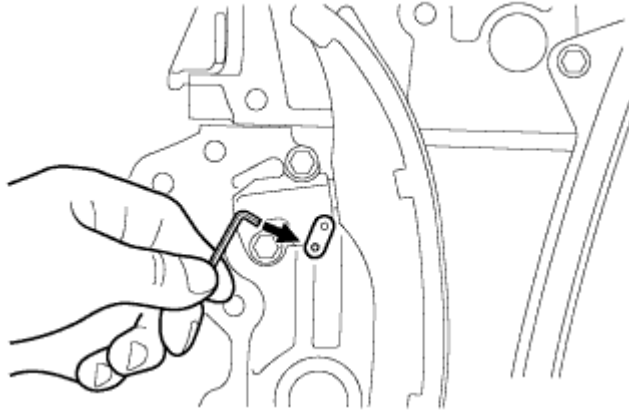

2. Insert a hexagon wrench into the hole in the stopper plate to lock with the plunger pushed in.

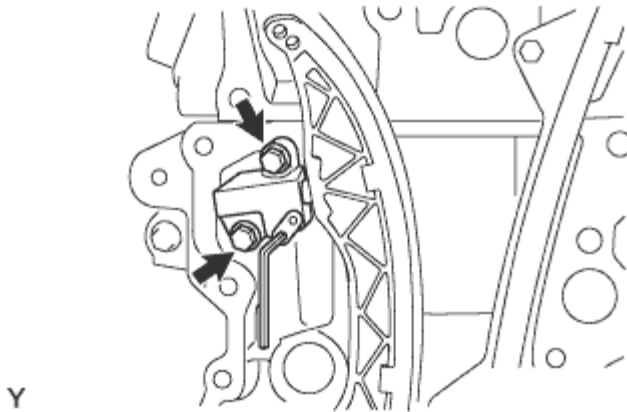

3. Remove the 2 bolts and remove the timing chain tensioner.

| |
|-------------------------------------|
| 31. REMOVE TIMING CHAIN TENSION ARM |
|-------------------------------------|

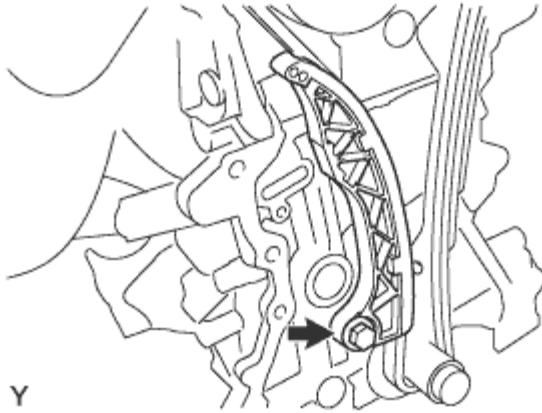

1. Remove the bolt and remove the chain tensioner arm.

32. REMOVE CHAIN SUB-ASSEMBLY

33. REMOVE TIMING CHAIN GUIDE

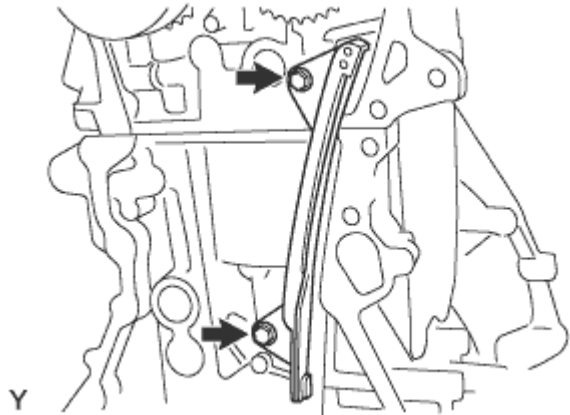

1. Remove the 2 bolts and remove the timing chain guide.

34. REMOVE CRANKSHAFT TIMING GEAR OR SPROCKET

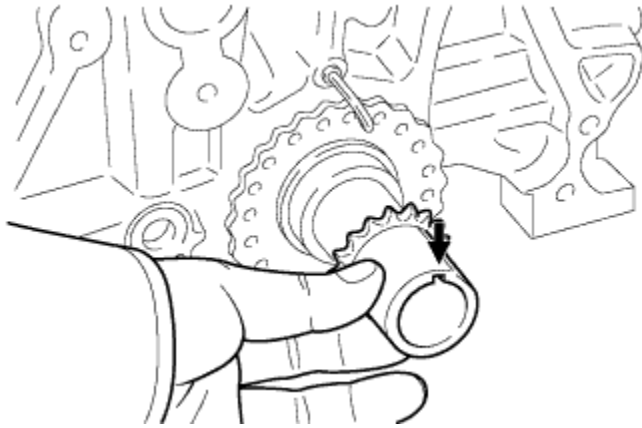

1. Remove the crankshaft timing chain gear or sprocket from the crankshaft.

35. REMOVE CRANKSHAFT STRAIGHT PIN

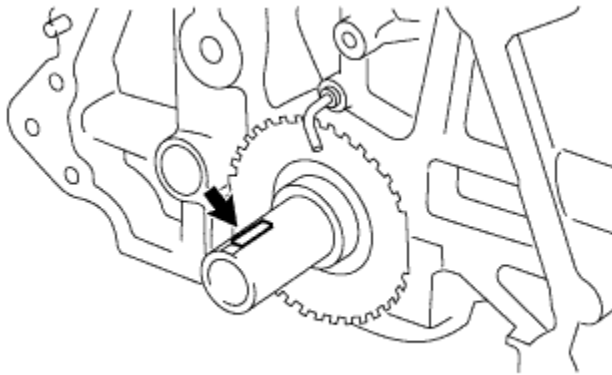

Y

1. Remove the crankshaft straight pin from the crankshaft.

36. REMOVE OIL JET

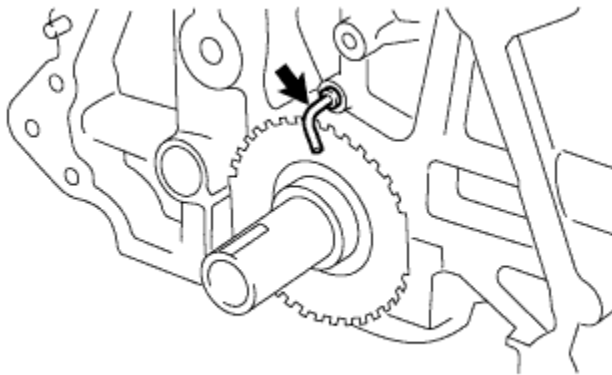

Y

1. Remove the oil jet from the cylinder block.

37. REMOVE CAMSHAFT TIMING SPROCKET ASSEMBLY

1. Slightly turn the crankshaft clockwise.

NOTICE:

Do not allow the lifted valve and piston to come into the contact with each other when removing the camshaft.

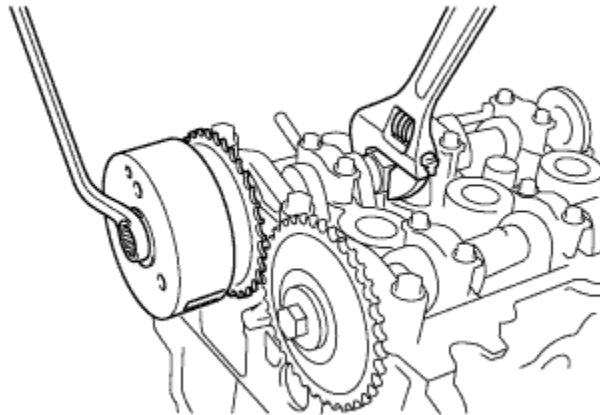

Y

2. Remove the bolt from the sprocket while holding the hexagonal portion of the camshaft.

3. Remove the camshaft timing sprocket from the camshaft.

38. REMOVE CAMSHAFT TIMING GEAR OR SPROCKET

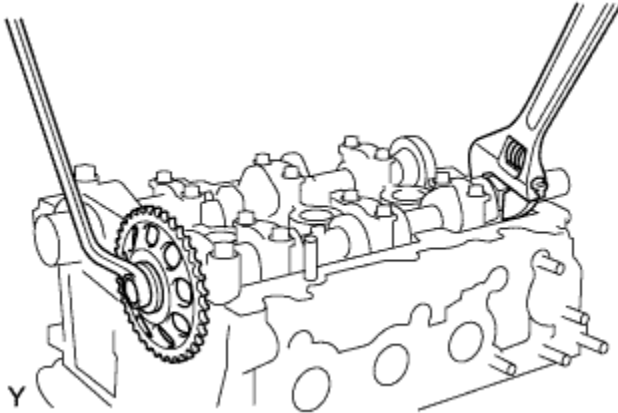

1. Remove the bolt from the gear while holding the hexagonal portion of the camshaft.
2. Remove the camshaft timing gear from camshaft No. 2.

39. REMOVE CAMSHAFTS

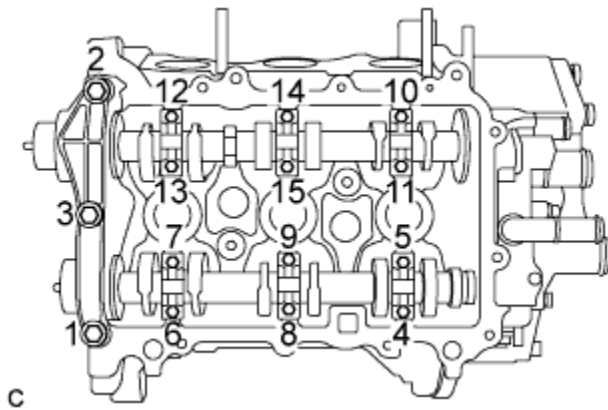

1. Remove the 15 bolts in the order shown in the illustration.
2. Remove camshaft bearing caps No. 1 and No. 2.

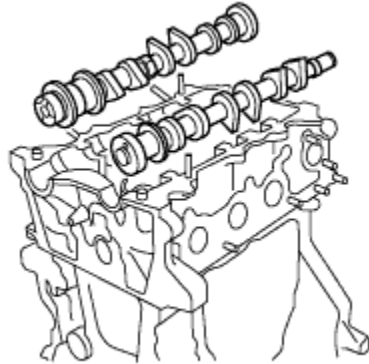

c

3. Remove the 2 camshafts.

40. REMOVE VENTILATION BAFFLE PLATE



y

1. Remove the 6 bolts and 2 nuts.

41. REMOVE ENGINE REAR OIL SEAL RETAINER

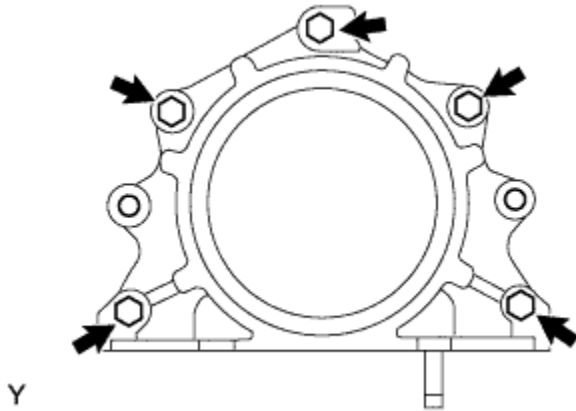

1. Remove the 5 bolts, and remove the oil seal retainer.

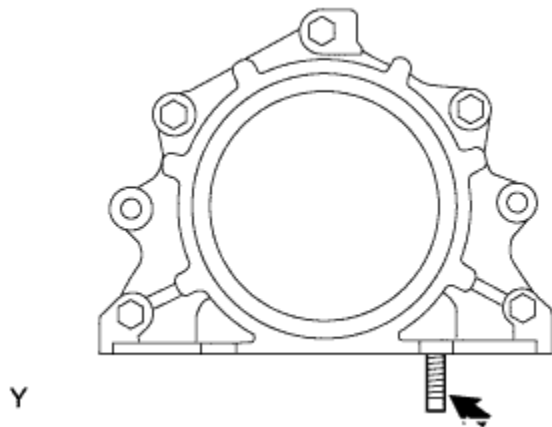

2. Remove the stud bolt.

42. REMOVE ENGINE REAR OIL SEAL

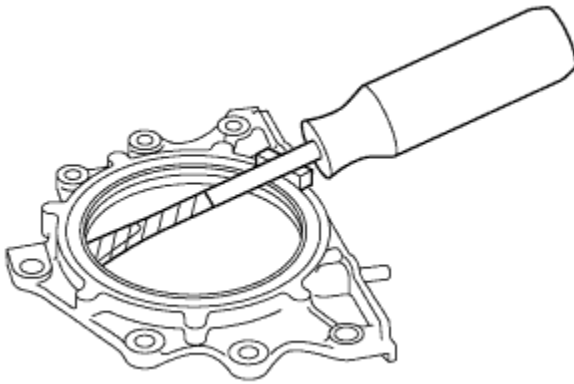

c

1. Using a screwdriver, remove the rear oil seal.

HINT:

Wrap the screwdriver tip in protective tape before use.

43. REMOVE VALVE LIFTER

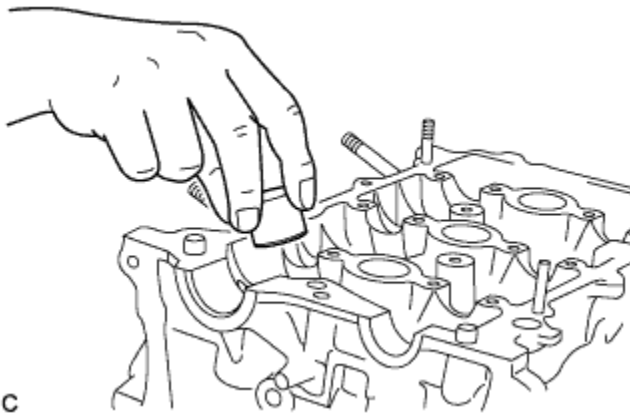

c

1. Remove the 12 valve lifters.

NOTICE:

- Record the inscribed mark on the valve lifters for each valve after removing them.

- Arrange the valve lifters for each cylinder in order.

44. REMOVE CYLINDER HEAD SUB-ASSEMBLY

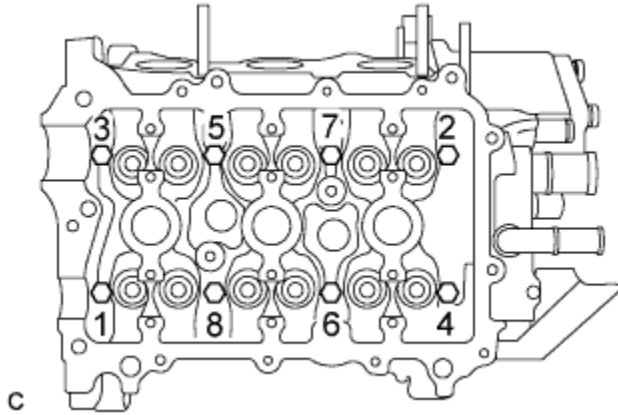

1. Using several steps, uniformly loosen and remove the 8 cylinder head bolts in the order shown in the illustration.
2. Remove the 8 plate washers from the cylinder head bolt holes.
3. Remove the cylinder head from the cylinder block.
4. Remove the 8 stud bolts from the cylinder head.

Upper Side:

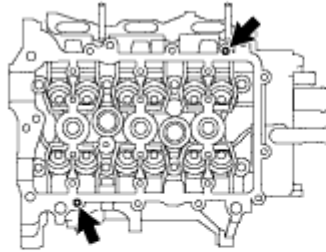

Intake Side:

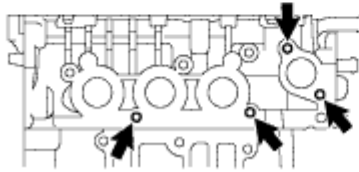

Exhaust Side:

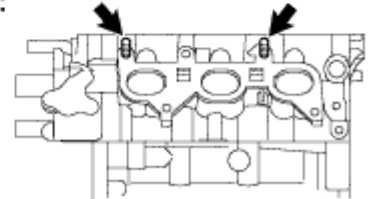

Y

45. REMOVE CYLINDER HEAD GASKET

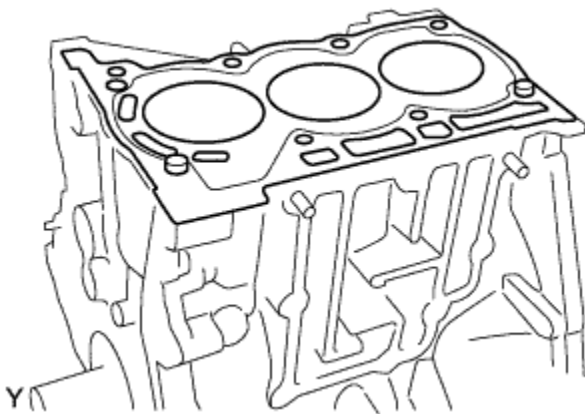

46. REMOVE VALVE

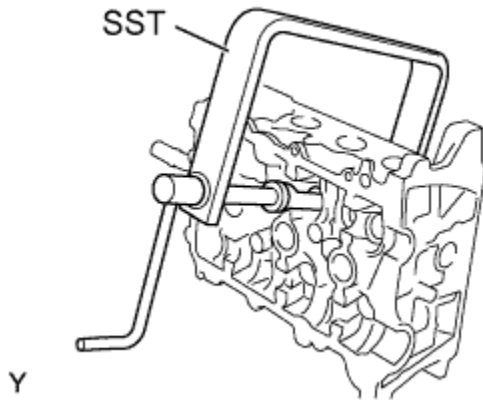

1. Using SST, remove the intake and exhaust valve spring retainer locks, valve retainer springs and compression spring.

SST
09202-70020

NOTICE:

Arrange the removed parts for each cylinder in order.

2. Remove the intake and exhaust valves.

NOTICE:

Arrange the removed parts for each cylinder in order.

47. REMOVE TIGHT PLUG NO. 1

Front Side:

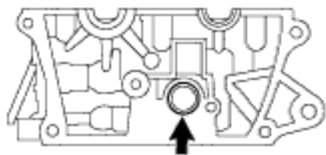

Upper Side:

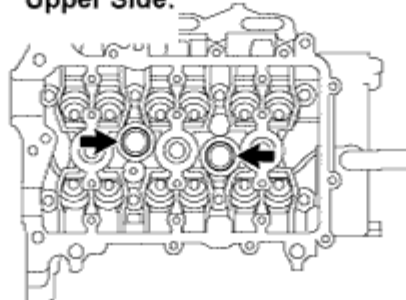

Rear Side:

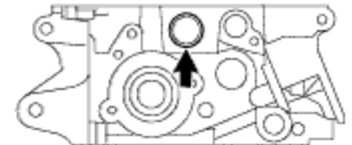

Y

1. Remove the 4 tight plugs from the cylinder head.

48. REMOVE CYLINDER HEAD OIL ORIFICE

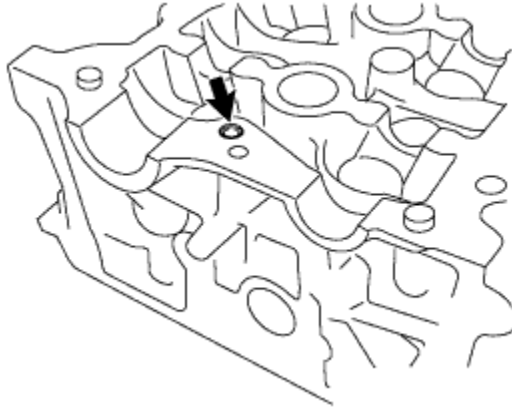

Y

1. Remove the cylinder head oil orifice.

49. REMOVE CONNECTING ROD SUB-ASSEMBLY

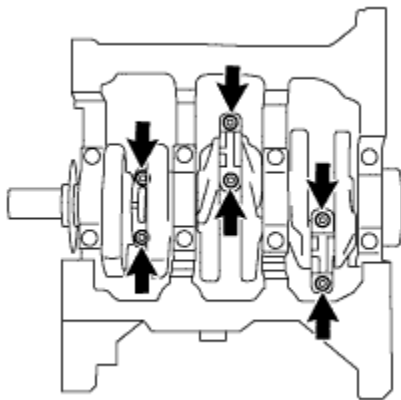

Y

NOTICE:

Do not turn the crankshaft.

1. Remove the 6 connecting rod bolts and remove the 3 connecting rod bearing caps.

NOTICE:

Arrange the removed parts for each cylinder in order.

2. Push the piston, connecting rod and upper bearing through the top of the cylinder block.

HINT:

- Keep the piston, connecting rod and cap together.
 - Arrange the piston and connecting rod for each cylinder in order.
3. Remove the 3 connecting rod bearings from the connecting rod sub-assembly.

50. REMOVE PISTON RING SET

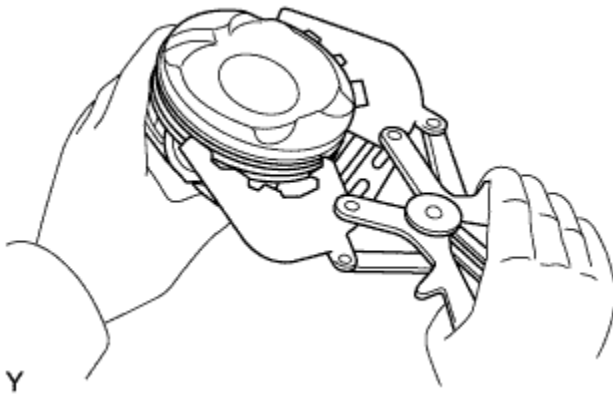

1. Using a piston ring expander, remove the No. 1 compression ring, No. 2 compression ring and oil ring.

51. REMOVE WITH PIN PISTON SUB-ASSEMBLY

SST

09221-25026 (09221-00021, 09221-00030, 09221-00130, 09221-00141, 09221-00150)

HINT:

- The piston and pin are a matched set.
- Arrange the pistons, pins, connecting rods and bearings in the correct order.

52. REMOVE CRANKSHAFT

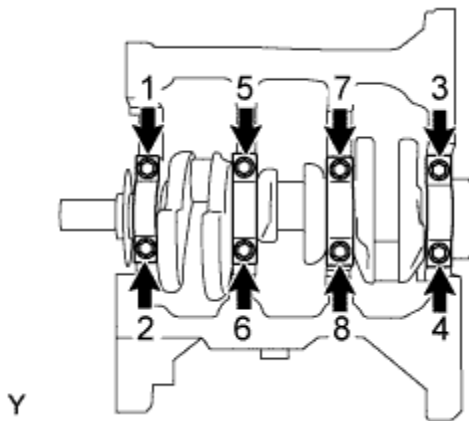

1. Remove the 8 bolts in the order shown in the illustration.

NOTICE:

Loosen the crankshaft bearing cap bolts in 2 or 3 steps, in the order shown in the illustration.

2. Remove the 4 crankshaft bearing caps and remove the crankshaft.

NOTICE:

Arrange the removed parts in the removed order.

HINT:

- If it is difficult to remove the crankshaft bearing cap, lightly tap it with a hammer.
- Move the top of the crankshaft bearing cap back and forth in the axial direction.

3. Remove the crankshaft bearing from the cylinder block and crankshaft bearing cap.

53. REMOVE CRANKSHAFT THRUST WASHER UPPER

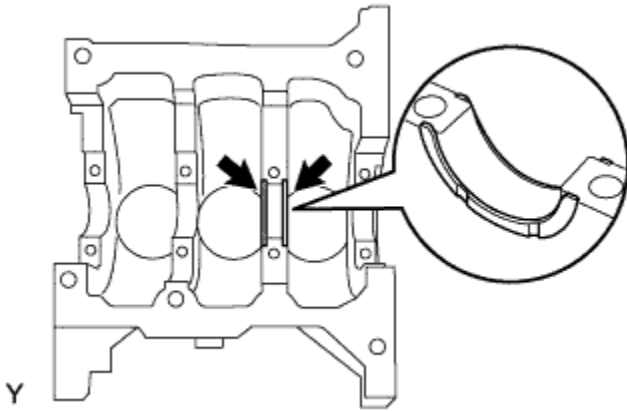

1. Remove the 2 crankshaft thrust washers from journal No. 3 of the cylinder block.

54. REMOVE OIL LEVEL GAUGE GUIDE SUPPORT

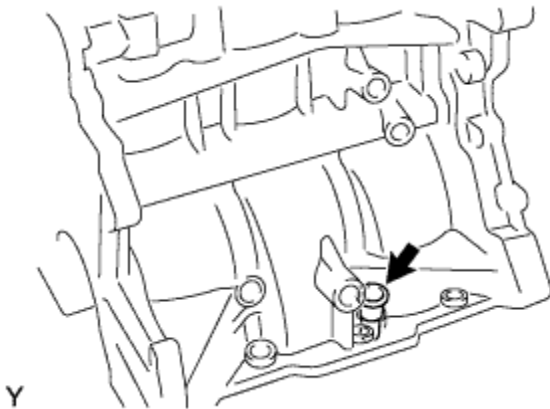

1. Remove the oil level gauge support from the cylinder block.

55. REMOVE PIN

1. Remove the 6 straight pins and 2 ring pins from the cylinder block.

Front Side:

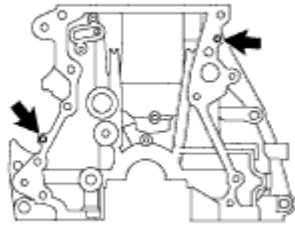

Upper Side:

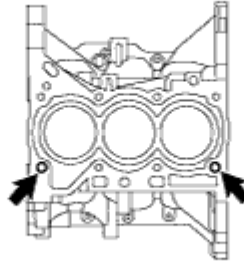

Rear Side:

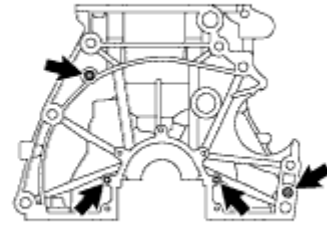

Y

ENGINE UNIT > INSPECTION

1. CLEAN CYLINDER HEAD

1. Using a scraper, clean the cylinder block surface and manifold of the cylinder head.

CAUTION:

- Wear protective goggles while servicing.
- Do not damage the cylinder head.
- Do not drop cylinder head gasket material into the water jacket.

2. CLEAN CYLINDER BLOCK

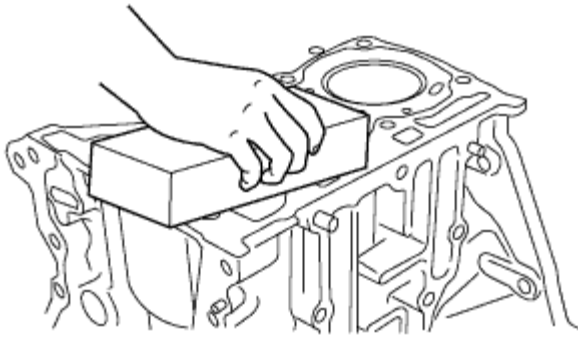

c

1. Using an oil stone or similar device, clean the chain cover surface, cylinder head surface, oil pan surface, and ventilation baffle plate surface of the cylinder block.

CAUTION:

Wear protective goggles while servicing.

NOTICE:

- Do not damage the cylinder block while servicing.
- Do not drop any cylinder head gasket material into the water jacket.

3. CLEAN OIL PAN

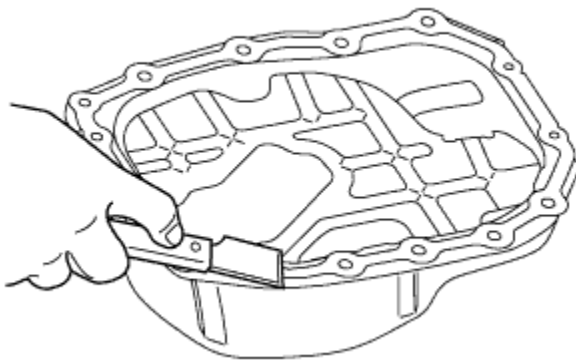

c

1. Clean the installation surface of the oil pan.

4. CLEAN PISTON

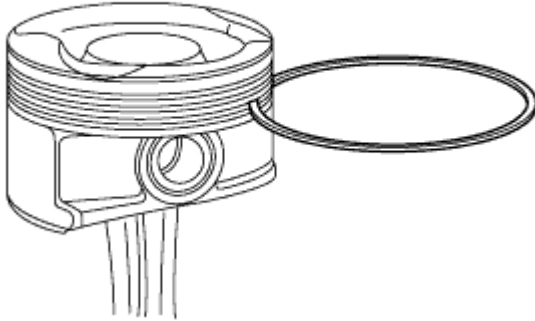

c

1. Using an old piston ring or similar device, remove all carbon on each piston.

CAUTION:

Wear protective goggles while servicing.

NOTICE:

Do not damage the piston while servicing.

2. Clean all the carbon off each part using solvent.

5. CLEAN VALVE

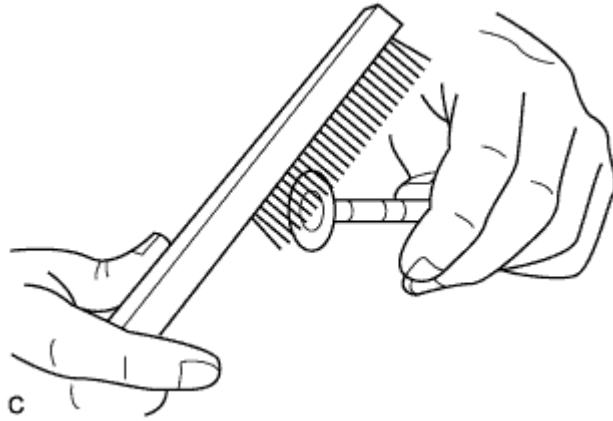

1. Remove all carbon on the valves.

CAUTION:
Wear protective goggles while servicing.

6. CLEAN CAMSHAFT BEARING CAP

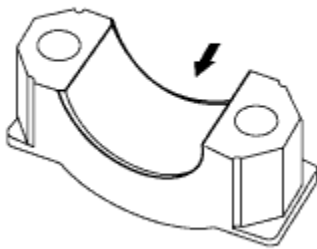

c

1. Clean the installation surfaces of the camshaft bearing No. 1 and No. 2 caps.

7. INSPECT CYLINDER HEAD

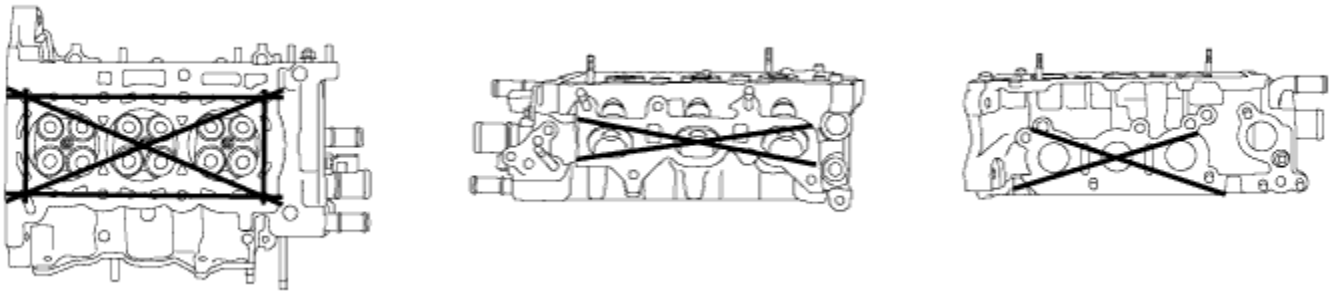

1. Using a straight edge and feeler gauge, measure the warpage of the contact surface indicated in the illustration.

Maximum warpage:
0.05 mm (0.002 in.)

If the warpage is greater than the maximum, replace the cylinder head.

2. Using a dye penetrate, check the combustion chamber, intake ports, exhaust ports and cylinder block surface for cracks.

8. INSPECT CYLINDER HEAD SET BOLT

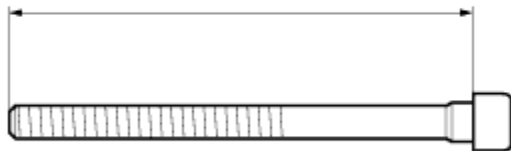

1. Using vernier calipers, measure the cylinder head bolt length.

Maximum length:
123.5 mm (4.862 in.)

If the length is greater than the maximum, replace the cylinder head bolt.

9. INSPECT CYLINDER BLOCK

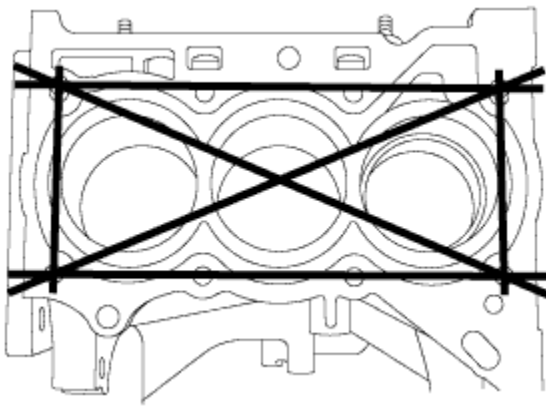

1. Using a straight edge and feeler gauge, measure the warpage of the contact surface indicated in the illustration.

Maximum warpage:
0.05 mm (0.002 in.)

If the warpage is greater than the maximum, replace the cylinder block.

10. INSPECT CYLINDER BORE

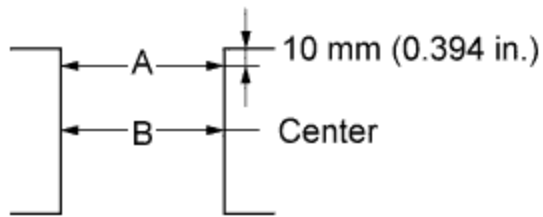
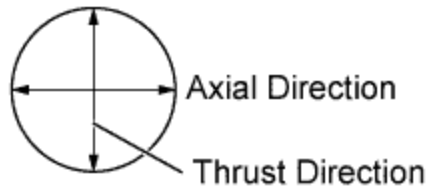
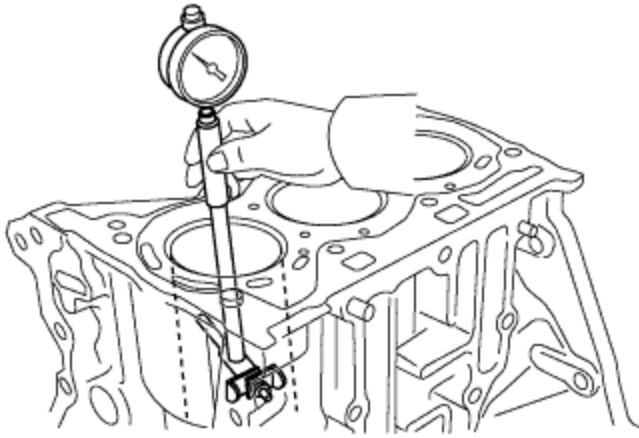

c

1. Using a cylinder gauge, measure the cylinder bore diameter at positions A and B in the thrust and axial directions.
If the average diameter of 4 positions is greater than the maximum, replace the cylinder block.

Standard diameter:

71.000 to 71.013 mm (2.79527 to 2.79578 in.)

Maximum diameter:

71.013 mm (2.79578 in.)

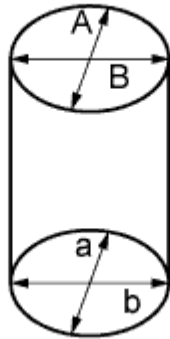

c

2. Calculate the elliptic degree and tapered amount from the measured values.

Maximum elliptic degree and tapered amount:
0.02 mm (0.0008 in.)

HINT:

- Elliptic degree: $A - B$ or $a - b$
- Tapered amount: $A - a$ or $B - b$

11. INSPECT OIL JET

1. Check the oil jet for damage or clogging.
If necessary, replace the oil jet.

12. INSPECT CHAIN SUB-ASSEMBLY

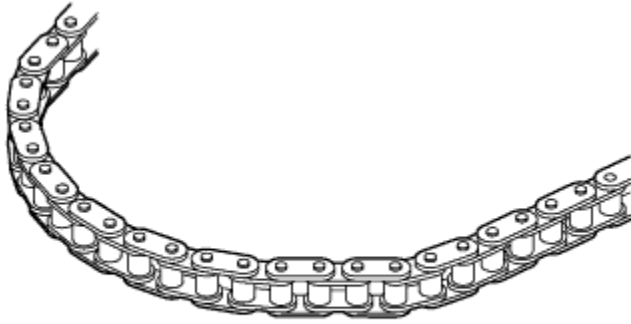

C

1. Visually check the timing chain for wear or cracks.
If the timing chain is not normal, replace the timing chain and check the sprocket.

13. INSPECT TIMING CHAIN TENSION ARM

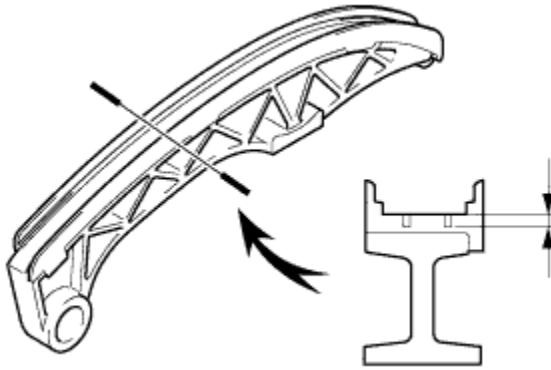

Y

1. Inspect the wear of the timing chain tension arm.

Maximum thickness:
0.5 mm (0.02 in.)

If the thickness is greater than the maximum, replace the timing chain tension arm.

14. INSPECT TIMING CHAIN GUIDE

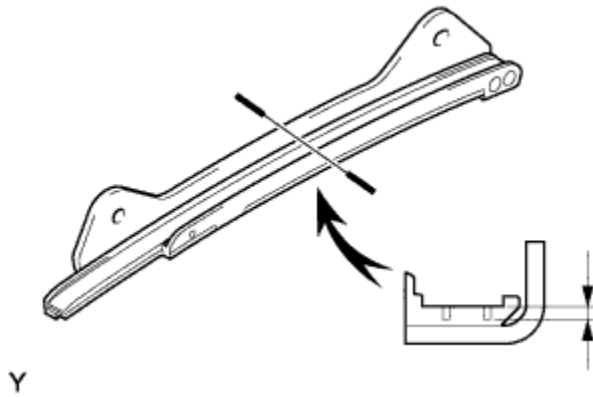

Y

1. Check the timing chain guide.

Maximum thickness:
0.5 mm (0.02 in.)

If the thickness is greater than the maximum, replace the timing chain guide.

15. INSPECT CHAIN TENSIONER ASSEMBLY NO. 1

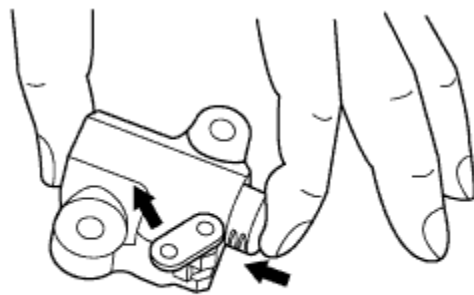

C

1. While holding the stopper plate of chain tensioner assembly No. 1 with your fingers, check that the plunger operates smoothly.
2. Release the stopper plate and check that the plunger cannot be pushed with the stopper plate activated.
If chain tensioner assembly No. 1 is not as specified, replace chain tensioner assembly No. 1.

16. INSPECT CAMSHAFT

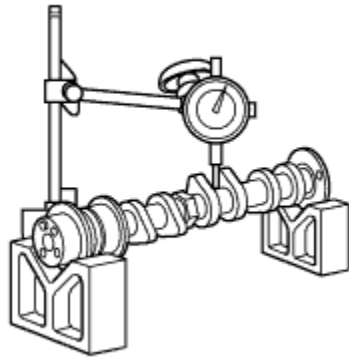

c

1. Inspect the camshaft for runout.
 1. Using V-blocks and a dial indicator, measure the runout of the 3rd journal.

Maximum circle runout:

0.03 mm (0.0012 in.)

HINT:

The runout is the half of the value on the indicator when the camshaft is turned 1 revolution.

If the circle runout is greater than the maximum, replace the camshaft.

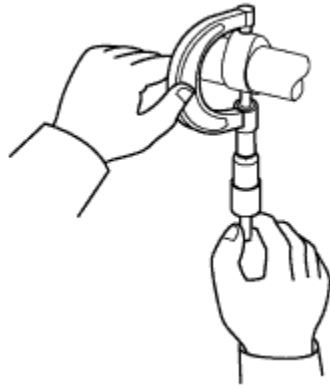

c

2. Inspect the cam lobes.

1. Using a micrometer, measure the cam lobe height.

Standard cam lobe height:

| Item | Specification |
|-------------------|---|
| Camshaft | 41.54 to 41.64 mm (1.6354 to 1.6394 in.) |
| Camshaft No. 2 | 40.97 to 41.07 mm (1.6310 to 1.6169 in.) |

Minimum cam lobe height:

| Item | Specification |
|-------------------|--------------------------|
| Camshaft | 41.44 mm (1.6315 in.) |
| Camshaft No. 2 | 40.87 mm (1.6091 in.) |

If the cam lobe height is less than the minimum, replace the camshaft.

| |
|--|
| 17. INSPECT CAMSHAFT THRUST CLEARANCE |
|--|

1. Install the 2 camshafts.

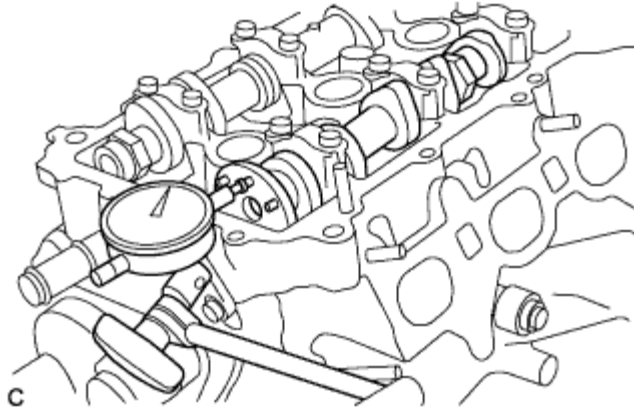

2. Using a dial indicator, measure the thrust clearance while moving the camshaft back and forth.

Standard thrust clearance:
0.100 to 0.225 mm (0.00394 to 0.00886 in.)
Maximum thrust clearance:
0.240 mm (0.00944 in.)

If the thrust clearance is greater than the maximum, replace the cylinder head. If damage is found on the camshaft thrust surfaces, replace the camshaft.

18. INSPECT CAMSHAFT OIL CLEARANCE

1. Clean the 7 bearing caps and camshaft journals.
2. Place the camshafts on the cylinder head.

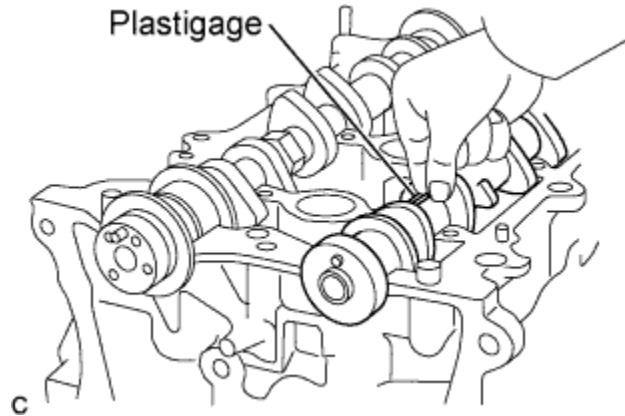

3. Lay a strip of Plastigage on the journal in the axial direction.

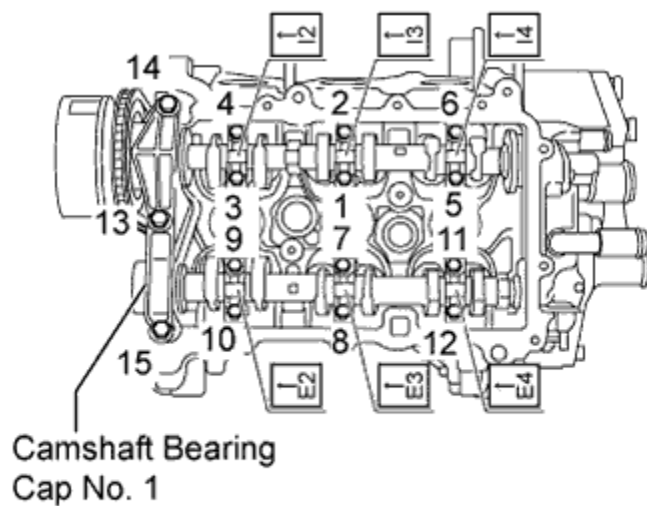

4. Place camshaft bearing caps No. 1 and No. 2 and tighten the bolts to the specified torque in the order shown in the illustration.

Torque:

Camshaft bearing cap No. 1:

15 N*m { 153 kgf*cm , 11 ft.*lbf }

Camshaft bearing cap No. 2:

13 N*m { 128 kgf*cm , 9 ft.*lbf }

NOTICE:

Install camshaft bearing caps No. 1 and No. 2 with the front marks facing engine front.

5. Remove the 7 bearing caps.

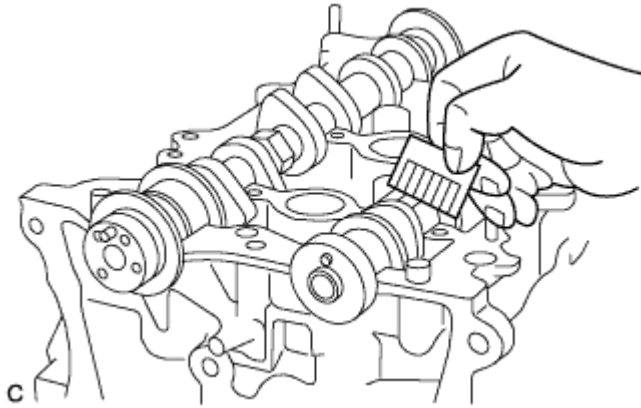

6. Measure the Plastigage at its widest point.

Standard oil clearance:

Camshaft:

0.025 to 0.061 mm (0.00098 to 0.00240 in.) (for Camshaft bearing No. 1)

0.035 to 0.072 mm (0.00138 to 0.00283 in.) (for Camshaft bearing No. 2)

Camshaft No. 2:

0.037 to 0.073 mm (0.00146 to 0.00287 in.) (for Camshaft bearing No. 1)

0.035 to 0.072 mm (0.00138 to 0.00283 in.) (for Camshaft bearing No. 2)

19. INSPECT CAMSHAFT TIMING SPROCKET ASSEMBLY

1. Check the camshaft timing sprocket for wear and damage.
If the camshaft timing sprocket is not in good condition, replace the camshaft timing sprocket.
2. Install the camshaft timing sprocket onto the camshaft.

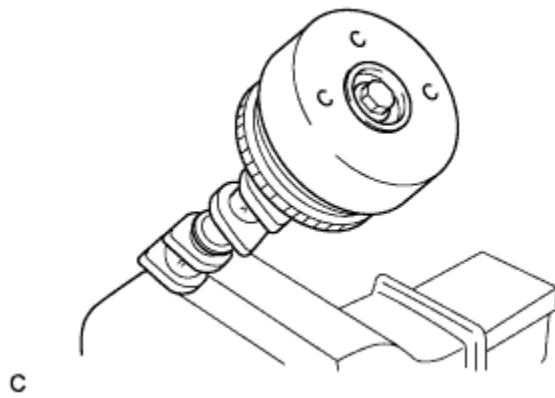

3. Hold the hexagonal portion of the camshaft assembly in a vise.

NOTICE:

Do not disassemble the camshaft timing sprocket.

4. Tighten the bolts to the specified torque.

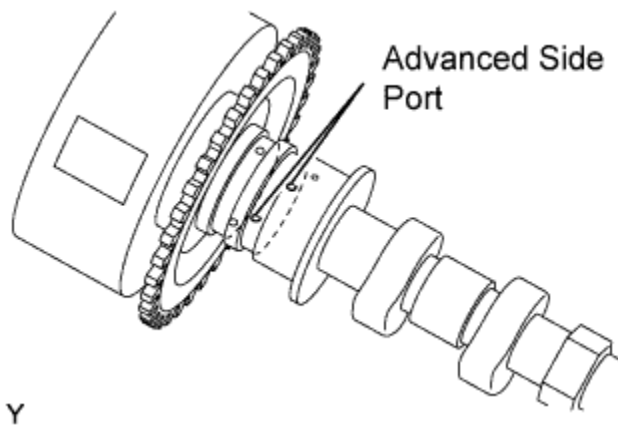

5. Plug either the advanced side port or the camshaft assembly with your finger or tape.

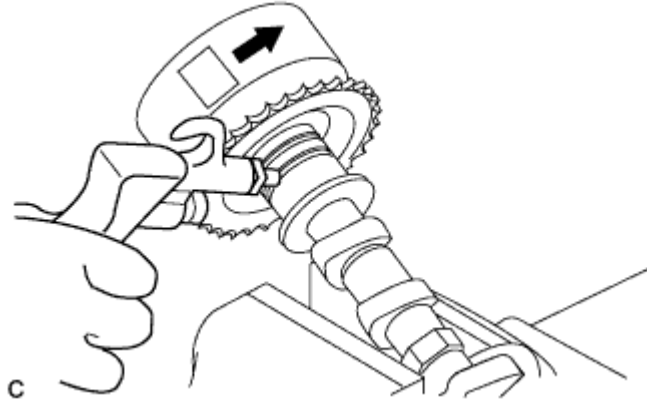

6. Apply pressure to the other advanced side path.

NOTICE:

Cover the paths to prevent oil from splashing.

HINT:

The lock for the most retarded position will be released.

7. Make sure that the lock for the most retarded position of the camshaft timing sprocket is released and the sprocket can be moved smoothly within the movable range by hand.

NOTICE:

The camshaft timing sprocket will be locked if it is turned to the most retarded position.

8. Lock the camshaft timing sprocket in the most retarded position.

20. INSPECT CAMSHAFT TIMING GEAR OR SPROCKET

1. Check the camshaft timing gear for wear and damage.
If the camshaft timing gear is not in good condition, replace the camshaft timing gear.

21. INSPECT CRANKSHAFT TIMING GEAR OR SPROCKET

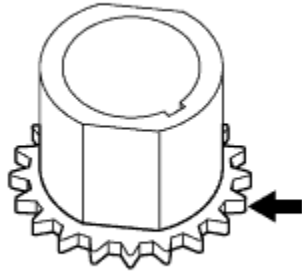

c

1. Check the crankshaft timing gear for wear and damage.
If the crankshaft timing gear is not in good condition, replace the crankshaft timing gear.

22. INSPECT INNER COMPRESSION SPRING

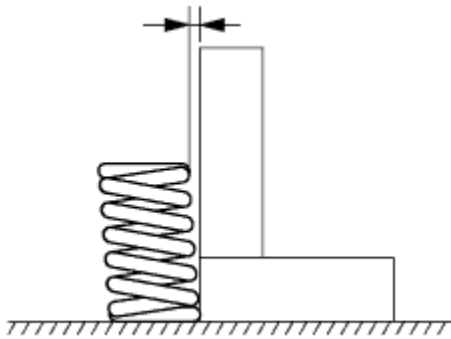

c

1. Using a straightedge and feeler gauge, measure the deviation of the inner compression spring.

Maximum deviation:
1.5 mm (0.059 in.)

If the deviation is greater than the maximum, replace the inner compression spring.

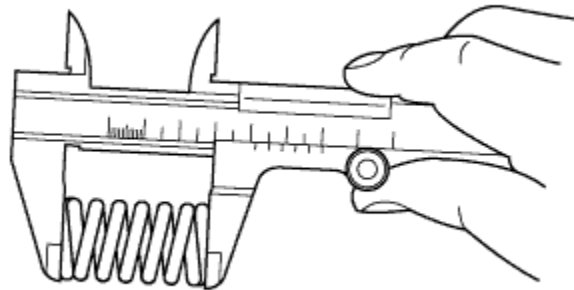

c

2. Using vernier calipers, measure the free length of the inner compression spring.

Free length:
51.63 mm (2.0327 in.)

If the length is not as specified, replace the inner compression spring.

23. INSPECT INTAKE VALVE

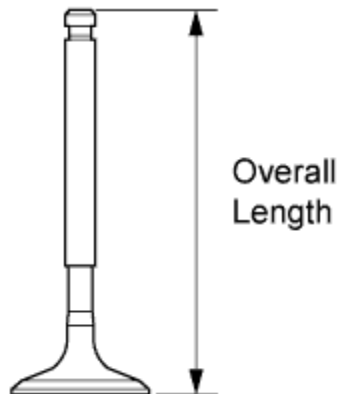

c

1. Using vernier calipers, check the valve overall length.

Standard overall length:

88.39 mm (3.4799 in.)

If the overall length is less than the specified value, replace the intake valve.

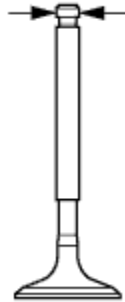

c

2. Using a micrometer, measure the diameter of the valve stem end.

Valve stem end diameter:
3.9 to 4.5 mm (0.154 to 0.177 in.)

If the diameter is not as specified, replace the intake valve.

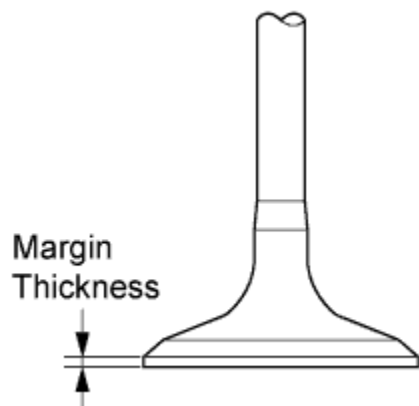

c

3. Using vernier calipers, check the valve head margin thickness.

Standard margin thickness:
1.05 to 1.45 mm (0.0413 to 0.0571 in.)

Minimum margin thickness:
0.7 mm (0.028 in.)

If the thickness is less than the minimum, replace the intake valve.

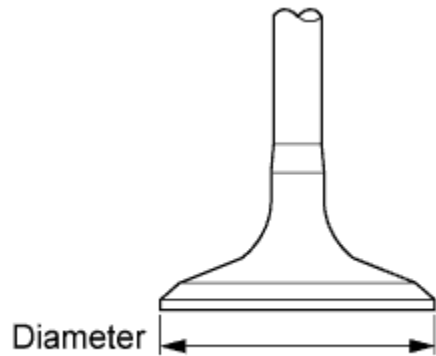

c

4. Using vernier calipers, check the valve head diameter.

Standard diameter:
27.35 to 27.65 mm (1.0768 to 1.0886 in.)

If the diameter is not as specified, replace the intake valve.

| |
|---------------------------|
| 24. INSPECT EXHAUST VALVE |
|---------------------------|

c

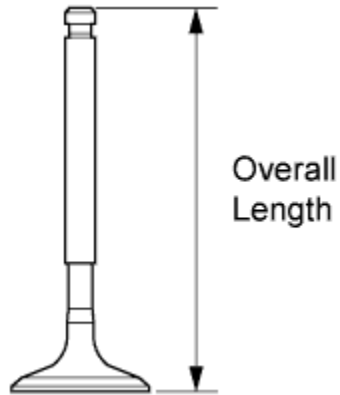

1. Using vernier calipers, check the valve overall length.

Standard overall length:
89.11 mm (3.5083 in.)

If the overall length is less than the specified value, replace the exhaust valve.

c

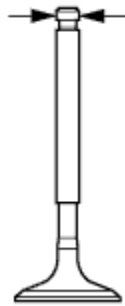

2. Using a micrometer, measure the diameter of the valve stem end.

Valve stem end diameter:
3.9 to 4.5 mm (0.154 to 0.177 in.)

If the diameter is not as specified, replace the exhaust valve.

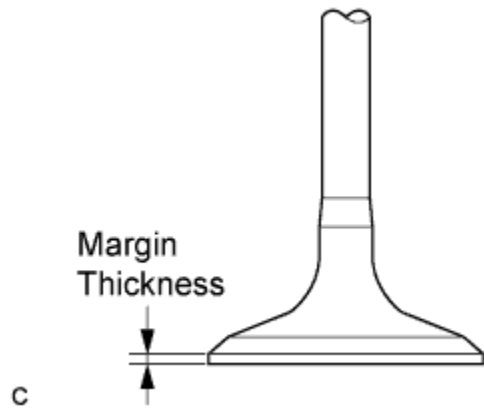

3. Using vernier calipers, check the valve head margin thickness.

Standard margin thickness:

1.10 to 1.50 mm (0.0433 to 0.0591 in.)

Minimum margin thickness:

0.7 mm (0.028 in.)

If the thickness is less than the minimum, replace the exhaust valve.

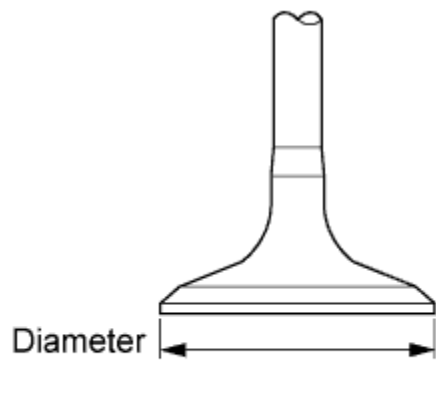

4. Using vernier calipers, check the valve head diameter.

Standard diameter:

23.45 to 23.75 mm (0.9232 to 0.9350 in.)

If the diameter is not as specified, replace the exhaust valve.

25. INSPECT INTAKE VALVE GUIDE BUSH OIL CLEARANCE

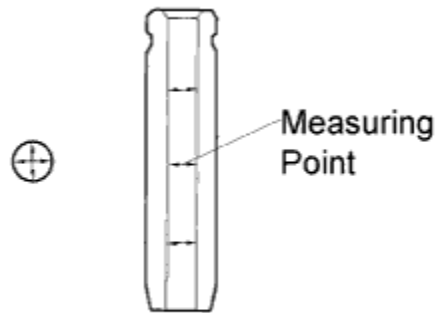

1. Using a caliper gauge, measure the inside diameter of the guide bush.

Intake valve guide bush inside diameter:
5.01 to 5.03 mm (0.19724 to 0.19803 in.)

If the diameter is not as specified, check the oil clearance.

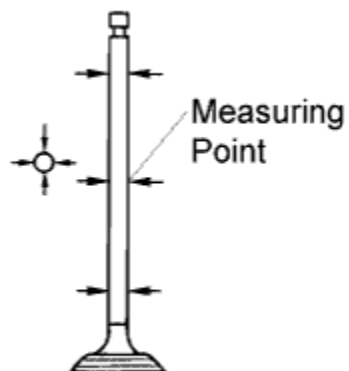

2. Subtract the valve stem diameter measurement from the guide bush inside diameter measurement to calculate the oil clearance.

Intake valve stem diameter:
4.970 to 4.985 mm (0.19567 to 0.19626 in.)
Standard oil clearance:
0.025 to 0.060 mm (0.00098 to 0.00236 in.)
Maximum oil clearance:
0.08 mm (0.00315 in.)

If the clearance is greater than the maximum, replace the valve and valve guide bush.

26. INSPECT EXHAUST VALVE GUIDE BUSH OIL CLEARANCE

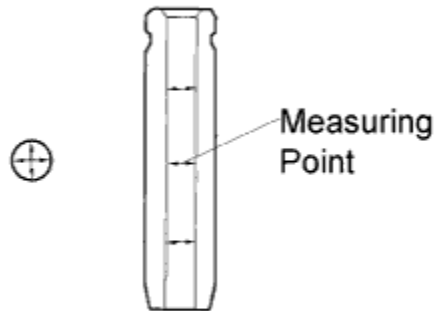

1. Using a caliper gauge, measure the inside diameter of the guide bush.

Exhaust valve guide bush inside diameter:
5.01 to 5.03 mm (0.19724 to 0.19803 in.)

If the diameter is not as specified, check the oil clearance.

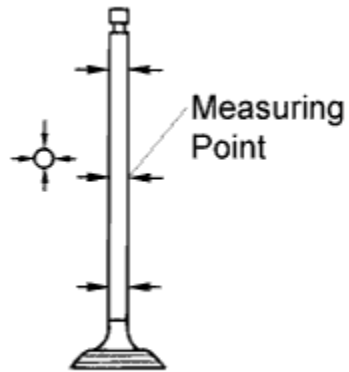

2. Subtract the valve stem diameter measurement from the guide bush inside diameter measurement to calculate the oil clearance.

Exhaust valve stem diameter:
4.965 to 4.980 mm (0.19547 to 0.19606 in.)
Standard oil clearance:
0.030 to 0.065 mm (0.00118 to 0.00256 in.)
Maximum oil clearance:
0.10 mm (0.00394 in.)

If the clearance is greater than the maximum, replace the valve and valve guide bush.

27. INSPECT PISTON

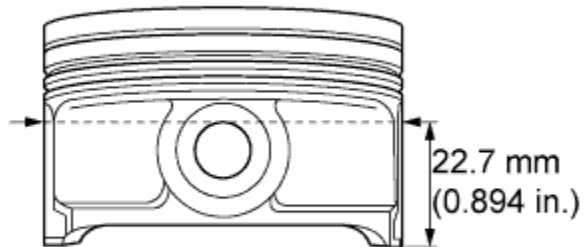

1. Measure the outer diameter of the piston in the vertical direction to the pin hole, at the point 22.7 mm (0.894 in.) away from the bottom end of the skirt.

Piston diameter:

70.921 to 70.931 mm (2.79216 to 2.79255 in.)

Minimum diameter:

70.921 mm (2.79216 in.)

If the diameter is not as specified, replace the piston.

28. INSPECT PISTON RING GROOVE CLEARANCE

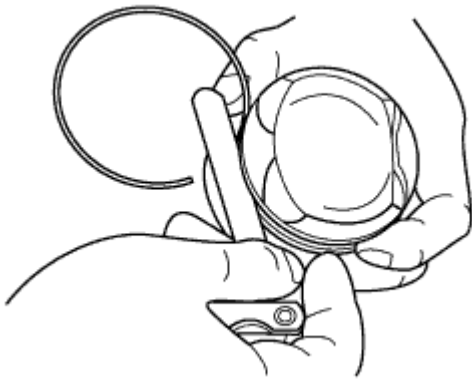

c

1. Using a feeler gauge, measure the clearance between a new piston ring and the wall of the ring groove.

Standard ring groove clearance:

| Item | Specification |
|------------|--|
| No. 1 ring | 0.02 to 0.07 mm (0.0008 to 0.0028 in.) |
| No. 2 ring | 0.02 to 0.06 mm (0.0008 to 0.0024 in.) |
| Oil ring | 0.020 to 0.065 mm (0.00079 to 0.00256 in.) |

Maximum ring groove clearance:

| Item | Specification |
|------------|----------------------|
| No. 1 ring | 0.07 mm (0.0028 in.) |

| | |
|------------|------------------------|
| No. 2 ring | 0.06 mm (0.0024in.) |
| Oil ring | 0.065 mm (0.00256 in.) |

If the ring groove clearance is greater than the maximum, replace the piston assembly.

29. INSPECT PISTON RING END GAP

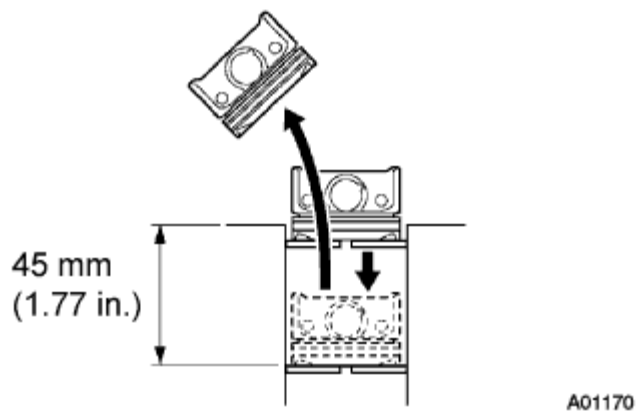

1. Using a piston, push the piston ring a little beyond the bottom of the ring travel, which is 45 mm (1.77 in.) from the top of the cylinder block.

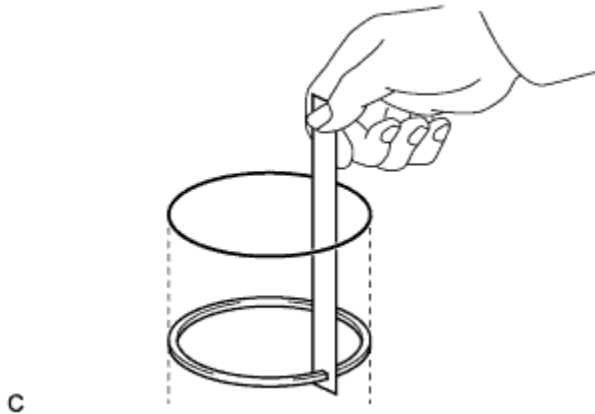

- Using a feeler gauge, measure the end gap.

Standard end gap:

| Item | Specification |
|------------|--|
| No. 1 ring | 0.20 to 0.30 mm (0.0079 to 0.0118 in.) |
| No. 2 ring | 0.40 to 0.60 mm (0.0157 to 0.0236 in.) |
| Oil ring | 0.10 to 0.40 mm (0.0039 to 0.0157 in.) |

Maximum end gap:

| Item | Specification |
|------------|----------------------|
| No. 1 ring | 0.79 mm (0.0311 in.) |
| No. 2 ring | 0.75 mm (0.0295in.) |
| Oil ring | 0.69 mm (0.0272in.) |

- If the end gap is greater than the maximum, replace the piston ring.
- If the end gap is greater than the maximum, even with a new piston ring, replace the cylinder block.

30. INSPECT PISTON OIL CLEARANCE

- Subtract the piston diameter measurement from the cylinder bore diameter measurement to calculate the oil clearance.

Standard oil clearance:

0.080 to 0.103 mm (0.00315 to 0.00406 in.)

Maximum oil clearance:

0.103 mm (0.00406 in.)

- If the clearance is greater than the maximum, replace all of the piston assemblies.
- If necessary, replace the cylinder block.

HINT:

- The oil clearance of the piston and cylinder block can be calculated by subtracting the cylinder inner diameter in the thrust direction from the piston outer diameter.

- Perform the measurement at the point with the most wear because there is joggling wear on the upper end of the piston ring sliding area.

31. INSPECT CONNECTING ROD SUB-ASSEMBLY

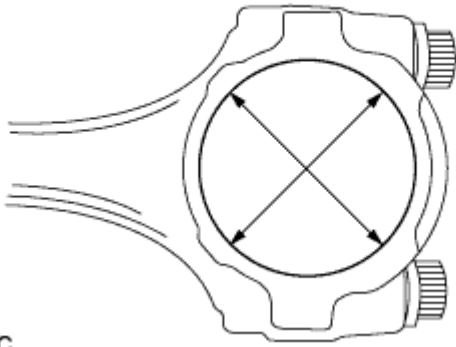

1. Using a cylinder gauge, measure the connecting rod sub-assembly big end diameter, as shown in the illustration.

Standard diameter:

43.000 to 43.024 mm (1.69291 to 1.63985 in.)

If the diameter is not as specified, replace the connecting rod.

32. INSPECT CONNECTING ROD BOLT

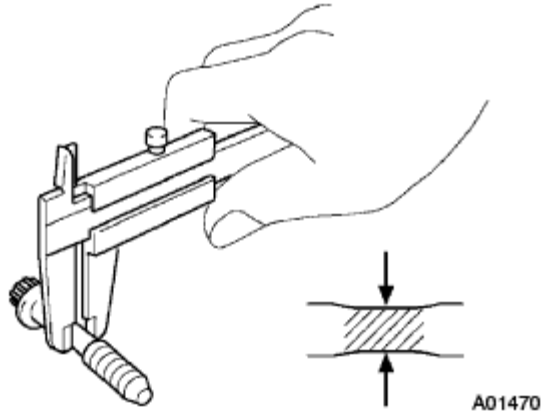

1. Using vernier calipers, measure the tension portion.

Minimum diameter:
6.4 mm (0.252 in.)

If the diameter is less than the minimum, replace the connecting rod bolt.

33. INSPECT CONNECTING ROD BEARING

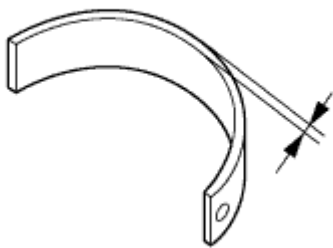

c

1. Using a micrometer, measure the thickness of the connecting rod bearing.

Standard thickness:
1.492 to 1.501 mm (0.05874 to 0.05909 in.)

If the thickness is not as specified, replace the connecting rod bearing.

34. INSPECT CONNECTING ROD THRUST CLEARANCE

1. Install the crankshaft with crankshaft journal bearing onto the cylinder block.
2. Install the thrust washer upper.
3. Install the piston with pin into the connecting rod.
4. Install the piston ring onto the piston.
5. Install the connecting rod assembly with connecting rod bearing onto the crankshaft.

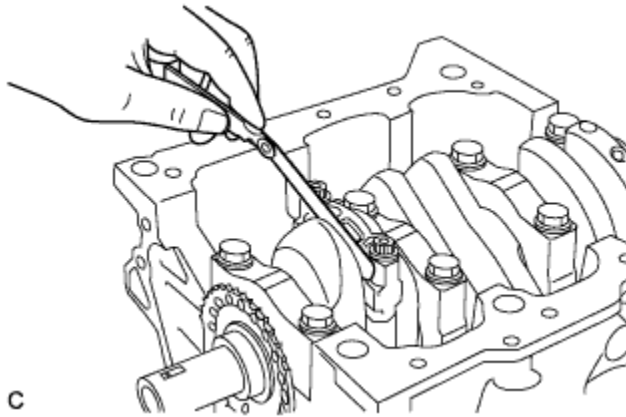

6. Using a feeler gauge, measure the thrust clearance of the connecting rod.

Standard thrust clearance:
0.1 to 0.3 mm (0.004 to 0.012 in.)
Maximum thrust clearance:
0.36 mm (0.0138 in.)

35. INSPECT CONNECTING ROD OIL CLEARANCE

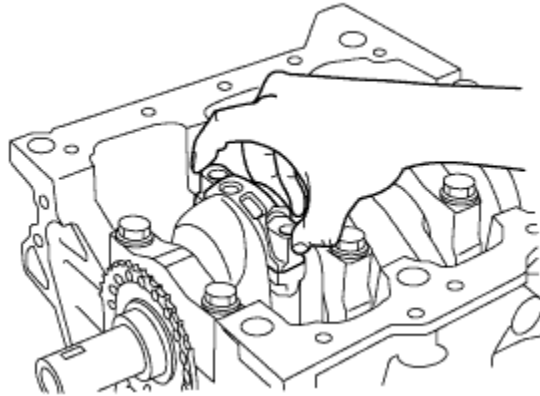

c

NOTICE:

Do not turn the crankshaft.

1. Remove the 2 bolts, connecting rod bearing cap and connecting rod bearing.

NOTICE:

Arrange the removed parts for each cylinder in order.

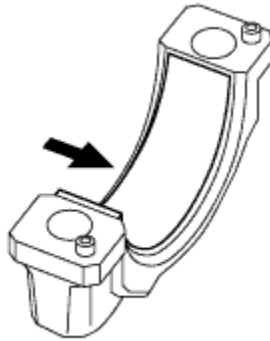

c

2. Clean the connecting rod bearing and crank pin.

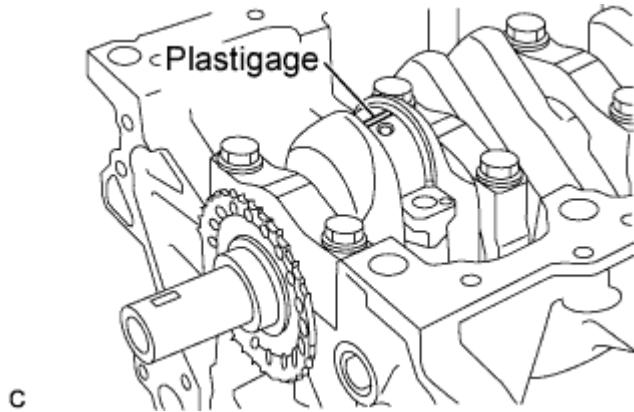

3. Lay a strip of Plastigage across the crank pin.
4. Apply a light coat of engine oil to the threads and under the heads of the connecting rod cap bolts.
5. Tighten the 2 bolts in several steps to the specified torque.

Torque:
15 N*m { 153 kgf*cm , 11 ft.*lbf }

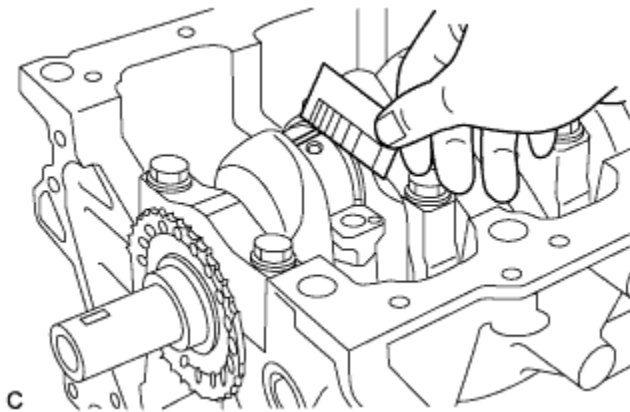

6. Remove the 2 bolts, and remove the connecting rod bearing cap and connecting rod bearing.

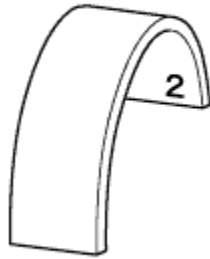

c

7. Measure the Plastigage at its widest point.

Standard oil clearance:

0.016 to 0.042 mm (0.00063 to 0.00165 in.)

Maximum oil clearance:

0.045 mm (0.00177 in.)

NOTICE:

Completely remove the Plastigage after the measurement.

HINT:

- If the oil clearance is greater than the maximum, replace the connecting rod bearing with one with the same mark.
- If the oil clearance is still greater than the maximum even after the connecting rod bearing is replaced, replace the crankshaft.

| Item | Mark | Specification |
|--|------|--|
| Connecting rod bearing cap bore diameter | 1 | 43.000 to 43.008 mm (1.69291 to 1.69323 in.) |
| | 2 | 43.009 to 43.016 mm (1.69324 to 1.69355 in.) |
| | 3 | 43.017 to 43.024 mm (1.69356 to 1.69385 in.) |
| Connecting rod bearing thickness | 1 | 1.492 to 1.495 mm (0.05874 to 0.05886 in.) |
| | 2 | 1.495 to 1.498 |

| | | |
|-------------------------------|---|--|
| | | mm (0.05886 to 0.05898in.) |
| | 3 | 1.498 to 1.501 mm (0.05898 to 0.05909 in.) |
| Crankshaft pin outer diameter | - | 39.992 to 40.000 mm (1.57445 to 1.57480 in.) |

HINT:

The procedures for measuring the connecting rod bearing cap bore diameter and the connecting rod thickness are described in the engine unit inspection section.

8. Perform the measurement for the other connecting rod oil clearance using the same procedure.

36. INSPECT CRANKSHAFT

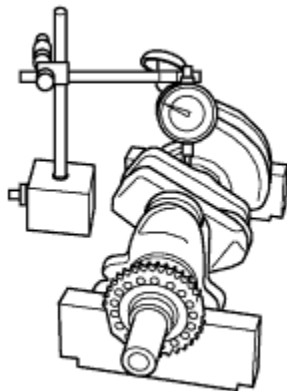

c

1. Using a dial indicator and V-blocks, measure the circle runout as shown in the illustration.

Maximum circle runout:
0.03 mm (0.0012 in.)

If the circle runout is greater than the maximum, replace the crankshaft.

HINT:

The runout is the half of the value on the indicator when the crankshaft is turned 1 revolution.

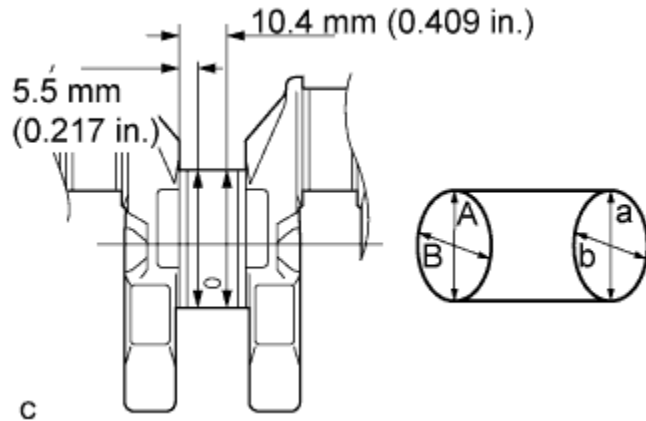

2. Using a micrometer, measure the diameter of each main journal at the points shown in the illustration.

Diameter:
43.988 to 44.000 mm (1.73181 to 1.73228 in.)

If the diameter is not as specified, check the crankshaft oil clearance.

3. Check each main journal for elliptic degree and tapered amount as shown.

Maximum elliptic degree and tapered amount:
0.03 mm (0.0012 in.)

If the elliptic degree or tapered amount is greater than the maximum, replace the crankshaft.

HINT:

- Elliptic degree: $A - B$ or $a - b$
- Tapered amount: $A - a$ or $B - b$

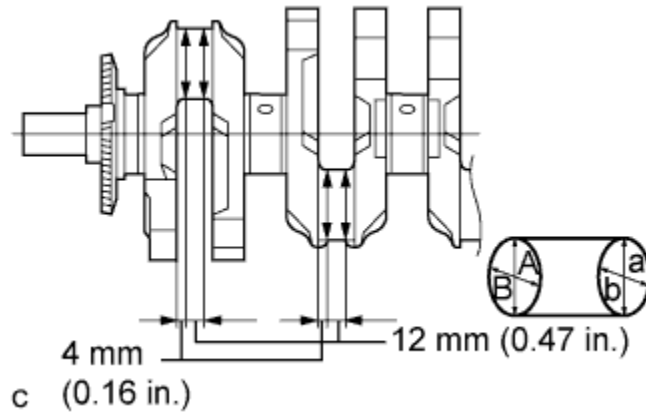

- Using a micrometer, measure the diameter of each crankshaft pin at the points shown in the illustration.

Diameter:

39.992 to 40.000 mm (1.57449 to 1.57480 in.)

If the diameter is not as specified, check the connecting rod oil clearance.

- Check each crankshaft pin for elliptic degree and tapered amount as shown.

Maximum elliptic degree and tapered amount:

0.03 mm (0.0012 in.)

If the elliptic degree or tapered amount is greater than the maximum, replace the crankshaft.

HINT:

- Elliptic degree: $A - B$ or $a - b$
- Tapered amount: $A - a$ or $B - b$

| |
|---|
| 37. INSPECT CRANKSHAFT THRUST CLEARANCE |
|---|

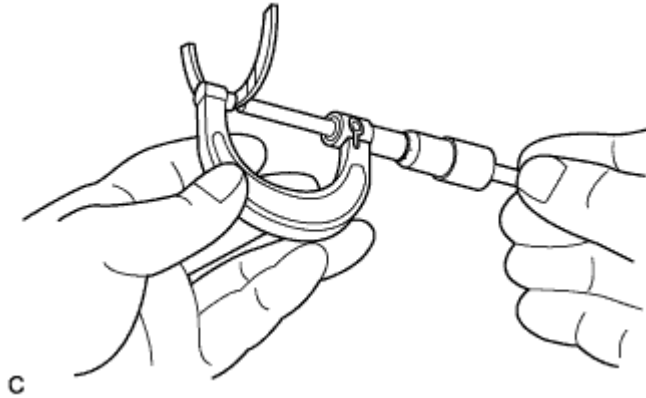

1. Install the crankshaft with crankshaft bearing onto the cylinder block.
2. Using a feeler gauge, measure the thrust clearance while prying the crankshaft back and forth with a screwdriver.

Standard clearance:

0.02 to 0.04 mm (0.0008 to 0.0016 in.)

Maximum clearance:

0.30 mm (0.0118 in.)

HINT:

- If the thrust clearance is greater than the maximum, replace the thrust washer.
- If the clearance is still greater than the maximum, replace the crankshaft.

| |
|--------------------------------------|
| 38. INSPECT CRANKSHAFT OIL CLEARANCE |
|--------------------------------------|

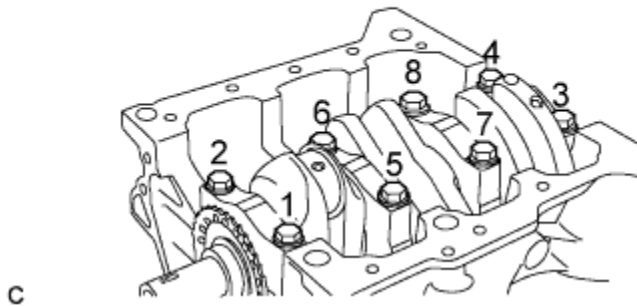

NOTICE:

Do not turn the crankshaft.

1. Remove the 8 bolts and 4 crankshaft bearing caps.
2. Clean the inner surfaces if the crankshaft bearing, the crankshaft bearing cap and the journals of the cylinder block and the crankshaft have been removed.
3. Check these parts for excessive wear and damage.

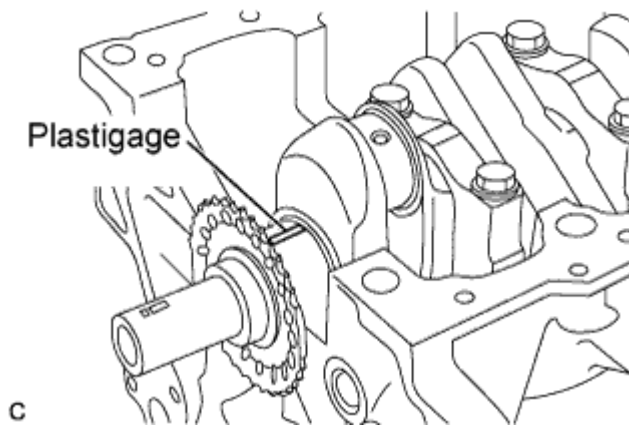

4. Lay a strip of Plastigage in the axial direction of the crankshaft journal.

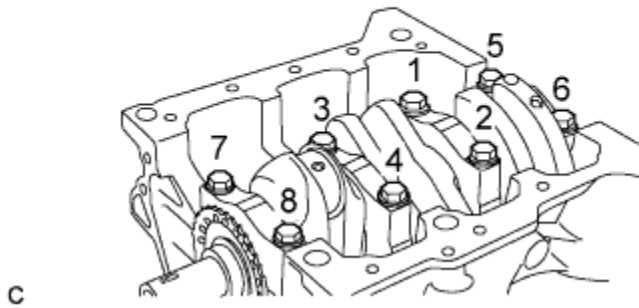

5. Tighten the 8 bolts to the specified torque.

Torque:

59 N*m { 602 kgf*cm , 44 ft.*lbf }

NOTICE:

Tighten the crankshaft bearing cap bolts in 2 or 3 steps, in the order shown in the illustration.

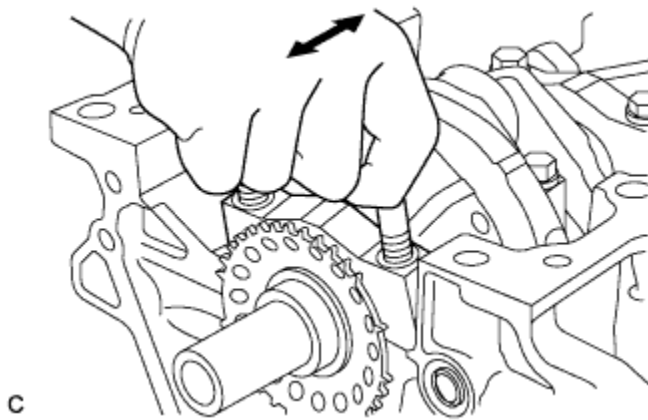

6. Remove the 2 bolts, then remove the crankshaft bearing cap and crankshaft bearing.

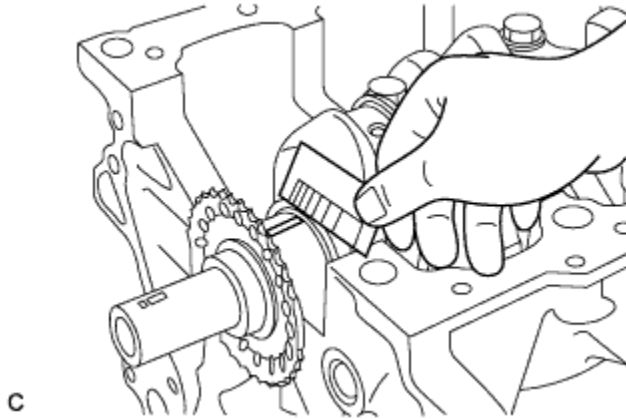

7. Measure the Plastigage at its widest point.

Standard oil clearance:

0.021 to 0.046 mm (0.00083 to 0.00181 in.)

Maximum oil clearance:

0.046 mm (0.00181 in.)

NOTICE:

Completely remove the Plastigage after the measurement.

HINT:

- If the oil clearance is greater than the maximum, replace the crankshaft bearing with one with the same mark.
- If the oil clearance is still greater than the maximum even after the crankshaft bearing is replaced, replace the crankshaft.
- When replacing a bearing, first check the number on the cylinder block for the bearing's respective journal. Then replace the bearing with one with the same number. Each bearing's standard thickness is indicated by a number 2, 3, 4 or 5 mark on its surface.

| Item | Mark | Specification |
|--------------------------------------|------|--|
| Cylinder block journal bore diameter | 1 | 48.000 to 48.006 mm (1.88976 to 1.89000 in.) |
| | 2 | 48.006 to 48.012 mm (1.89000 to 1.89023 in.) |
| | 3 | 48.012 to 48.018 mm (1.89023 to 1.89047 in.) |

| | | |
|--|---|--|
| Crankshaft journal diameter | 1 | 43.994 to 44.000 mm (1.73204 to 1.73228 in.) |
| | 2 | 43.988 to 43.994 mm (1.73171 to 1.73204 in.) |
| Standard bearing center wall thickness | 2 | 1.992 to 1.995 mm (0.07843 to 0.07854 in.) |
| | 3 | 1.995 to 1.998 mm (0.07854 to 0.07866 in.) |
| | 4 | 1.998 to 2.001 mm (0.07866 to 0.07878 in.) |
| | 5 | 2.001 to 2.004 mm (0.07878 to 0.07890 in.) |

39. INSPECT CRANKSHAFT THRUST WASHER UPPER

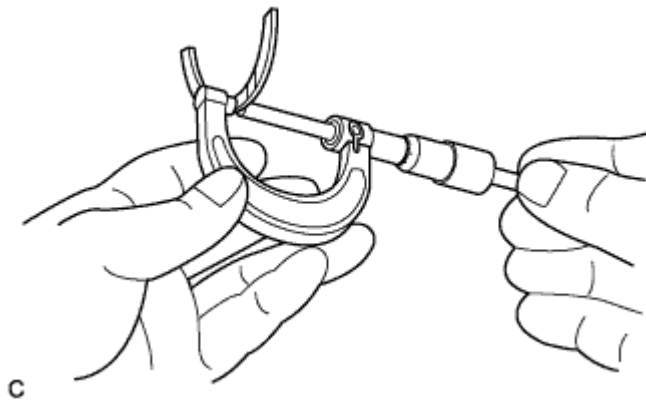

1. Using a micrometer, measure the thrust thickness of the crankshaft thrust washer upper.

Standard thickness:

1.94 to 1.99 mm (0.0764 to 0.0783 in.)

If the thickness is not as specified, replace the crankshaft thrust washer upper.

ENGINE UNIT > REPLACEMENT

1. REMOVE VALVE GUIDE BUSH

1. Gradually heat the cylinder head to 80 to 100°C (176 to 212°F).
2. Place the cylinder head on a wood block.

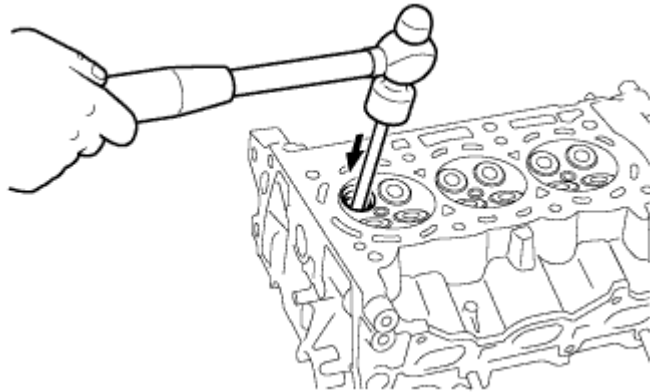

3. Using SST, tap out the valve guide bush.

SST
09201-87203

2. INSTALL VALVE GUIDE BUSH

1. Using a caliper gauge, measure the bush bore diameter of the cylinder head.

Bush bore diameter:
9.685 to 9.706 mm (0.38130 to 0.38213 in.)

If the diameter of the cylinder head is greater than 9.706 mm (0.38213 in.), machine the bush bore to the dimension of 9.735 to 9.756 mm (0.38327 to 0.38409 in.).

Valve guide bush diameter:

| Item | Diameter |
|----------|---|
| Standard | 9.727 to 9.738 mm (0.38339 to 0.38295 in.) |
| O/S 0.05 | 9.777 to 9.788 mm |

(0.38492 to 0.38535 in.)

2. Gradually heat the cylinder head to 80 to 100°C (176 to 212°F).
3. Place the cylinder head on a wooden block.

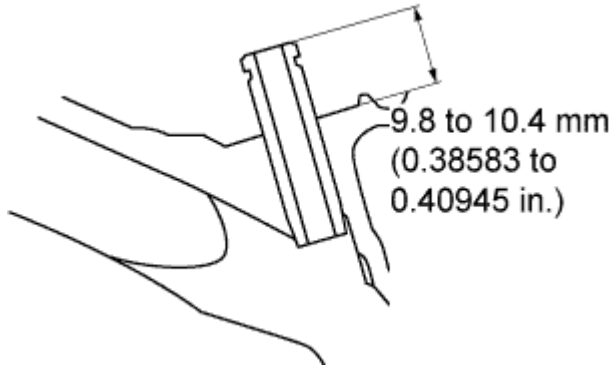

4. Using SST, tap in a new valve guide bush to the specified protrusion height.

SST

09201-87203

Protrusion height:

9.8 to 10.4 mm (0.38583 to 0.40945 in.)

5. Using a sharp reamer, ream the valve guide bush to the standard specified clearance between the valve guide bush and valve stem.

Standard oil clearance:

0.025 to 0.060 mm (0.00098 to 0.00236 in.)

ENGINE UNIT > REASSEMBLY

1. INSTALL PIN

Front Side:

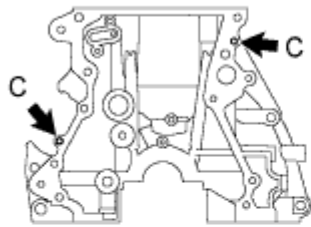

Upper Side:

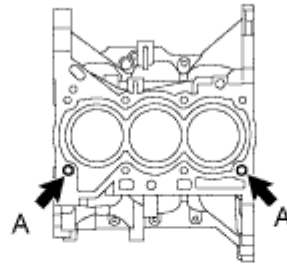

Rear Side:

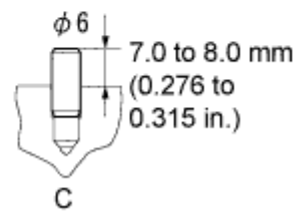
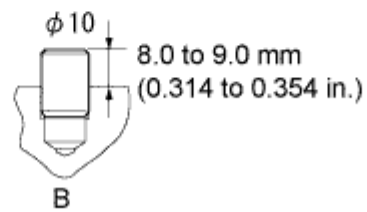
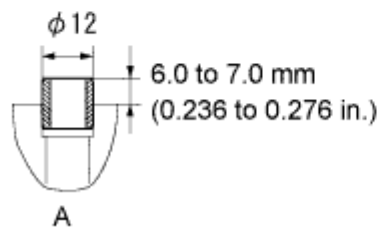
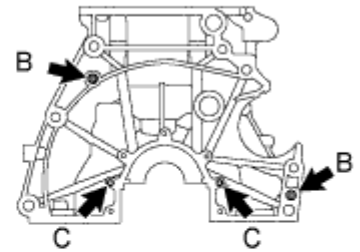

Y

1. Using a plastic-hammer, tap in the 6 straight pins and 2 ring pins, as shown in the illustration.

Standard protrusion:

Pin A:

6.0 to 7.0 mm (0.23622 to 0.27559 in.)

Pin B:

8.0 to 9.0 mm (0.31496 to 0.35433 in.)

Pin C:

7.0 to 8.0 mm (0.27559 to 0.31496 in.)

2. INSTALL OIL LEVEL GAUGE GUIDE SUPPORT

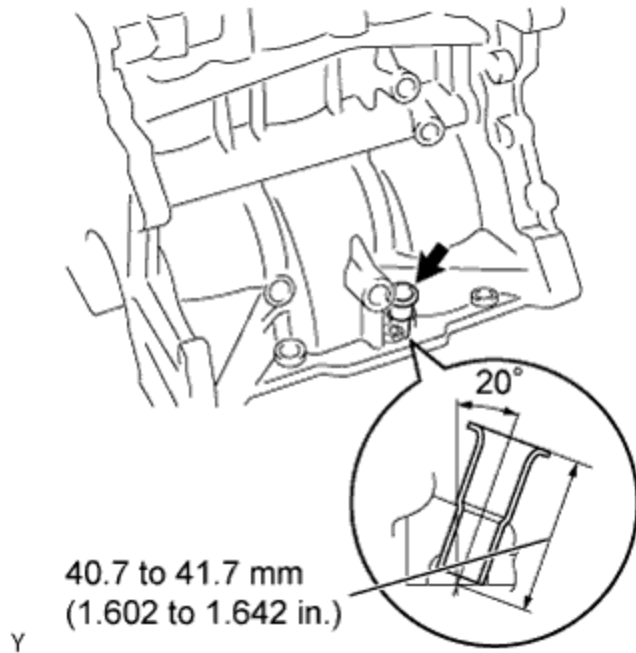

1. Install the oil level gauge guide support onto cylinder block.

3. INSTALL CRANKSHAFT BEARING

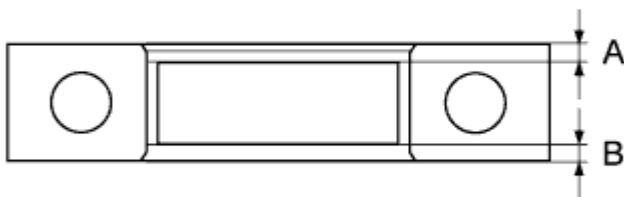

C

1. Align the crankshaft lower bearing with the bearing cap and install the crankshaft bearing cap.

NOTICE:

- Install the bearing cap so that the gap between A and B is less than 0.8 mm (0.031in.)
- Do not apply engine oil to the bearing and its contact surface.

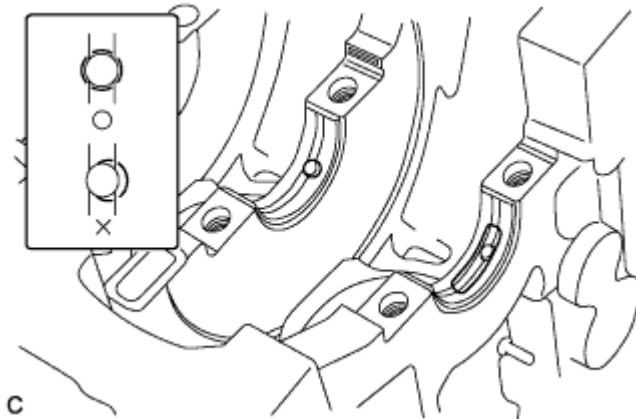

2. Align the crankshaft bearing (upper) with the oil hole in of the cylinder block and install the bearing.

NOTICE:

Do not apply engine oil to the bearing or its contact surface.

4. INSTALL CRANKSHAFT THRUST WASHER UPPER

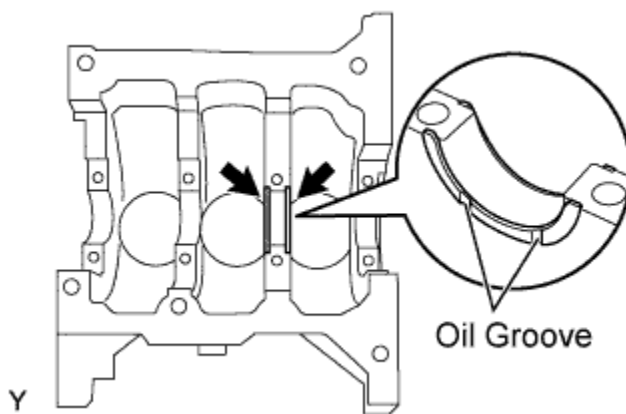

1. Apply engine oil to the oil groove.

2. Install the 2 crankshaft thrust washers onto the No. 3 journal position of the cylinder block with the oil grooves facing outward.

5. INSTALL CRANKSHAFT

1. Apply engine oil to the sliding surface of the crankshaft bearing (upper) and install the crankshaft.

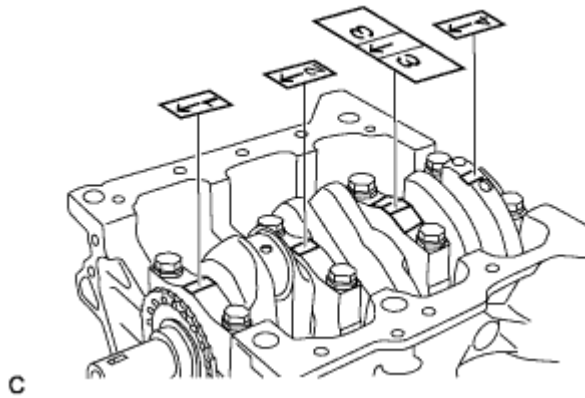

2. Apply engine oil to the sliding surface of the crankshaft bearing (lower) and install the crankshaft bearing cap with the front mark facing forward.

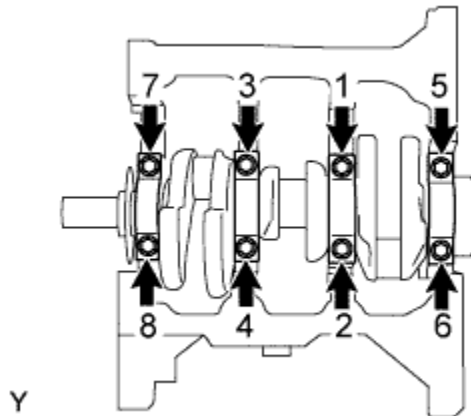

3. Apply engine oil to the crankshaft bolts and install them in 2 or 3 steps, in the order shown in the illustration.

Torque:

$59 \text{ N}\cdot\text{m}$ { $602 \text{ kgf}\cdot\text{cm}$, $44 \text{ ft}\cdot\text{lb}$ }

4. Make sure that the crankshaft turns smoothly.

6. INSTALL WITH PIN PISTON SUB-ASSEMBLY

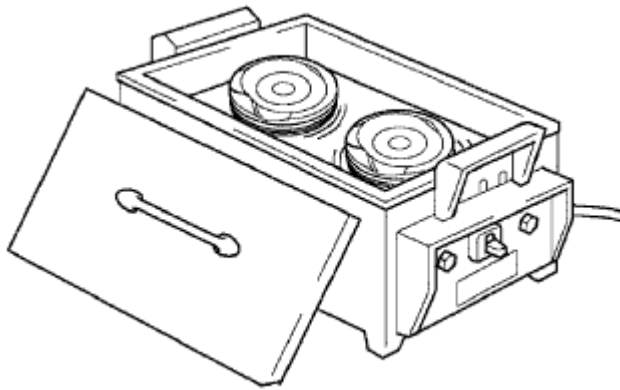

1. Gradually heat the piston up to 80 to 90°C (176 to 194°F).
2. Apply engine oil to the smaller end of a new connecting rod and a new piston pin.

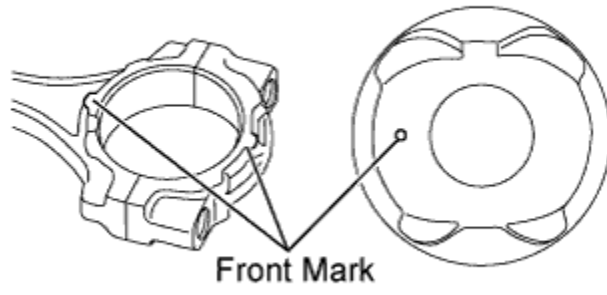

3. Align the front marks on the piston with the connecting rod and assemble them.

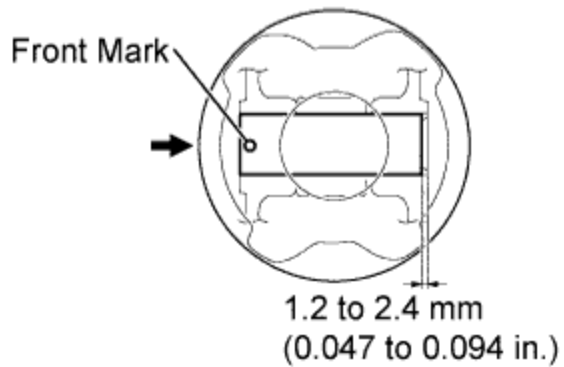
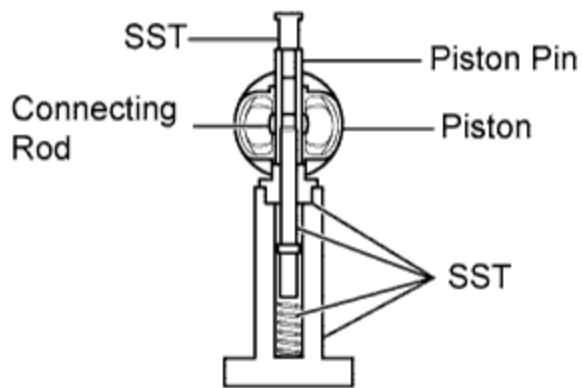
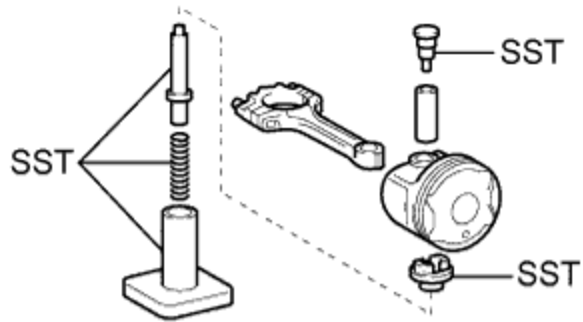

4. Using SST and a press, press in the piston pin.

SST

09221-25026 (09221-00021, 09221-00030, 09221-00130, 09221-00141, 09221-00150)

NOTICE:

- Press the piston pin in from the front mark side of the piston.

- Do not press the piston pin in at an angle.
5. Hold the connecting rod and check that the piston moves smoothly.

7. INSTALL PISTON RING SET

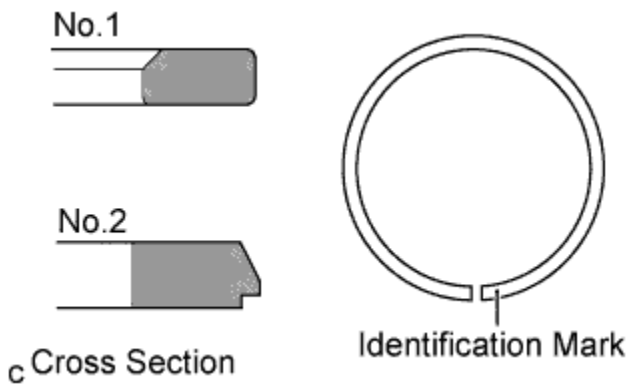

1. Install the oil ring.
2. Using a piston ring expander, install compression ring No. 2 and compression ring No. 1 with identification marks (T) facing upward.

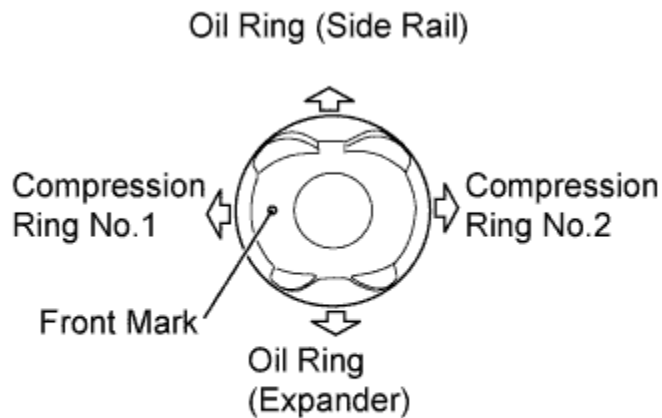

3. Install the rings so that each end faces as shown in the illustration.

8. INSTALL CONNECTING ROD BEARING

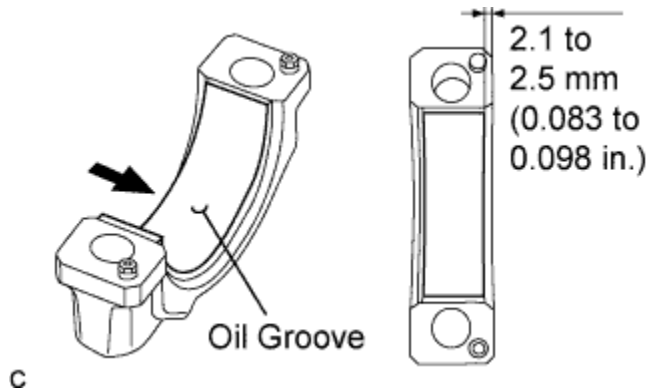

1. Align the connecting rod bearing oil groove of the connecting rod cap.
2. Install the connecting rod bearing onto the connecting rod bearing cap, as shown in the illustration.

NOTICE:

Do not apply engine oil to the bearing or its contact surface.

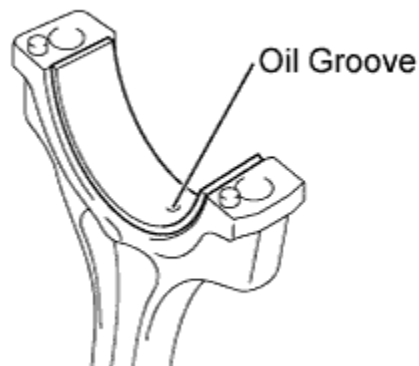

3. Align the connecting rod bearing oil groove of the connecting rod.

4. Install the connecting rod bearing onto the connecting rod.

NOTICE:

Do not apply engine oil to the bearing or its contact surface.

9. INSTALL CONNECTING ROD SUB-ASSEMBLY

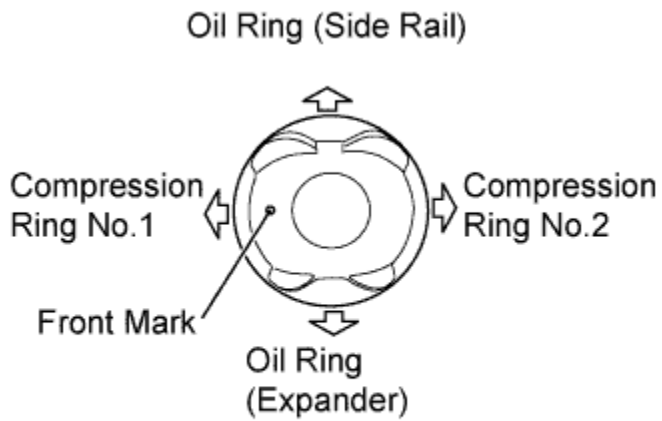

c

1. Make sure that the compression rings and oil ring are installed in the correct directions.

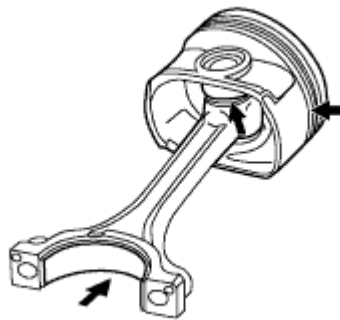

c

2. Apply engine oil to the sliding surfaces of the piston and connecting rod sub-assembly.

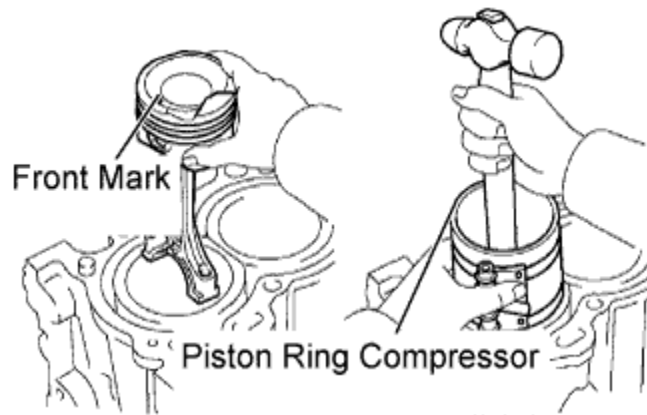

3. Using a piston ring compressor, push the numbered piston and connecting rod assemblies into each cylinder with the front mark of the piston facing forward.

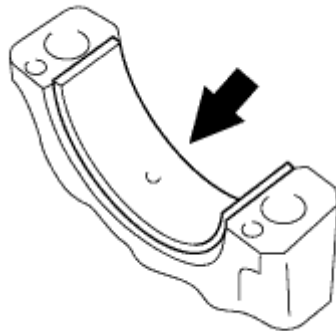

c

4. Apply engine oil to the sliding surface of the connecting rod bearing.

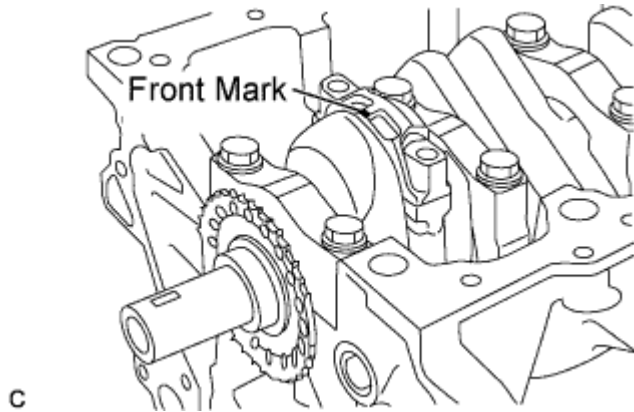

5. Install the connecting rod with the front mark of the connecting rod bearing cap facing forward.

NOTICE:

- Install the connecting rod bearing cap with the front mark facing forward. Make sure that the knock pin aligns with the knock pin hole.
- Do not change the connecting rod and connecting rod bearing cap combination.



c

6. Apply a light coat of engine oil to the seating position and threads of the connecting rod bolt.

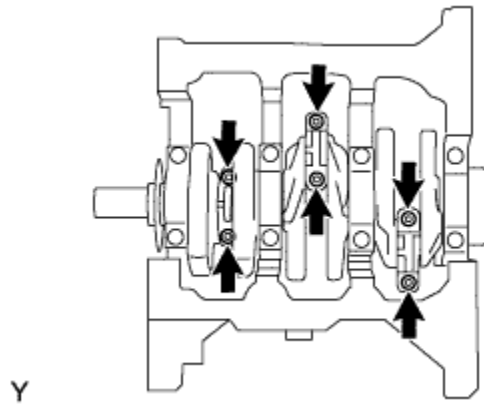

7. Alternately tighten the connecting rod bolts in 2 or 3 steps.

Torque:

15 N*m { 153 kgf*cm , 11 ft.*lbf }

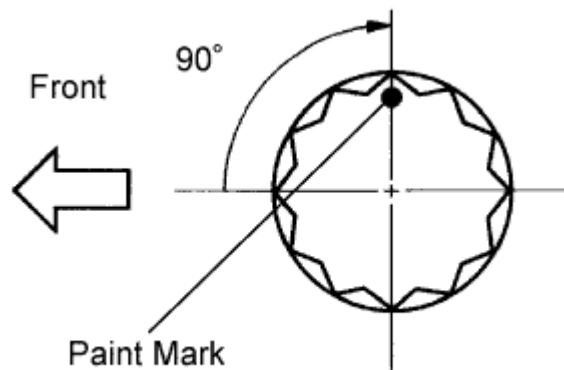

8. Mark the front of the connecting cap bolts with paint.
9. Retighten the cap bolts by an additional 90° as shown in the illustration.
10. Check that the crankshaft turns smoothly.

| |
|---------------------------------------|
| 10. INSTALL CYLINDER HEAD OIL ORIFICE |
|---------------------------------------|

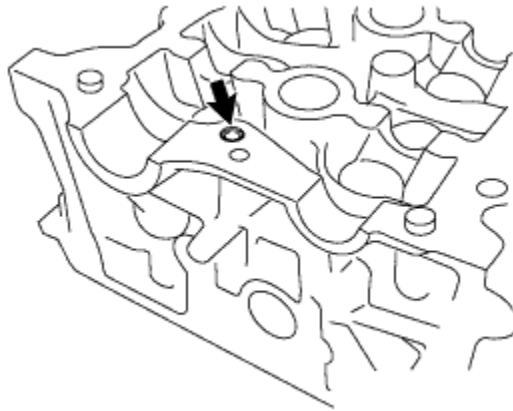

Y

1. Tap the cylinder head oil orifice in, as shown in the illustration.

11. INSTALL TIGHT PLUG NO. 1

Front Side:

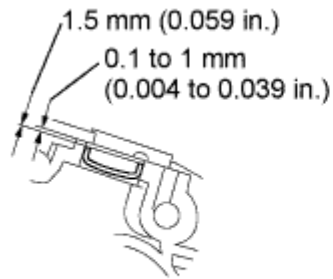
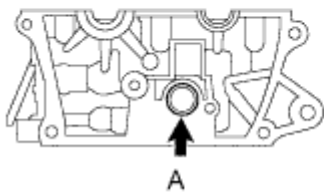

A

Upper Side:

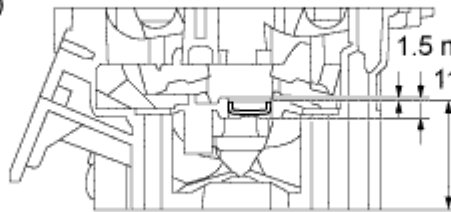
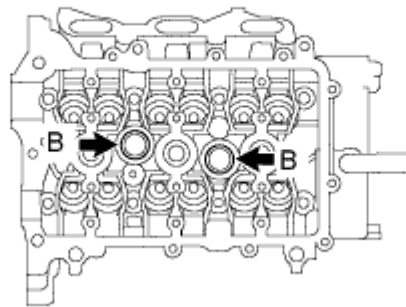

B

Rear Side:

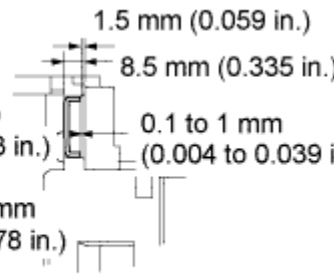
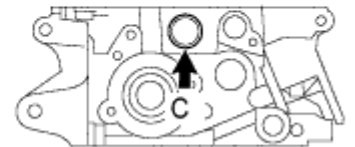

C

Y

1. Tap the tight plug in, as shown in the illustration.

12. INSTALL VALVE

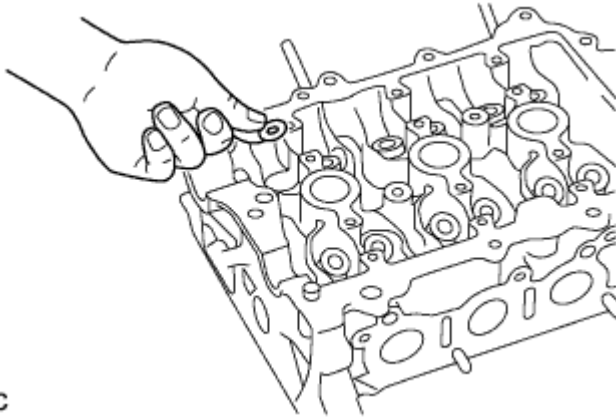

c

1. Install the 12 valve spring seats onto the cylinder head.

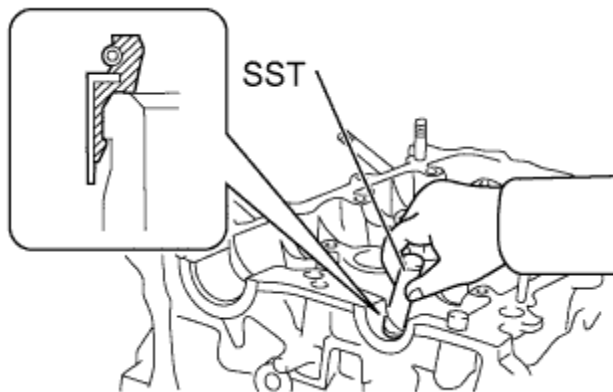

2. Apply a light coat of engine oil to 12 new valve stem oil seals.
3. Using SST, push in the valve stem oil seals by hand.

SST
09201-41020

Intake Side:

9.3 to 10.9 mm
(0.366 to 0.429 in.)

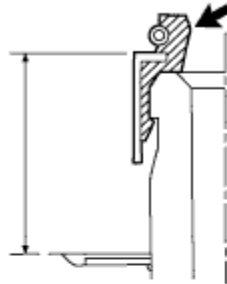

Exhaust Side:

9.7 to 11.3 mm
(0.382 to 0.445 in.)

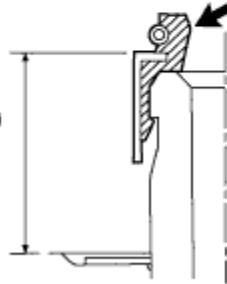

4. Make sure that each valve stem oil seal is pushed in to the specified depth, as shown in the illustration.

Standard depth:

Intake side:

9.7 to 11.3 mm (0.382 to 0.445 in.)

Exhaust side:

9.3 to 10.9 mm (0.366 to 0.429 in.)

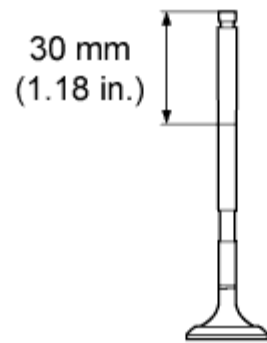

c

5. Apply engine oil to each valve area of 30 mm (1.18 in.) or more from its tip, as shown in the illustration.

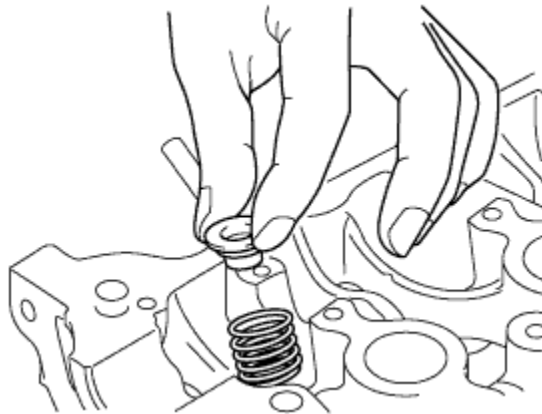

c

6. Install the valves, inner compression springs and valve seat retainers onto the cylinder head.

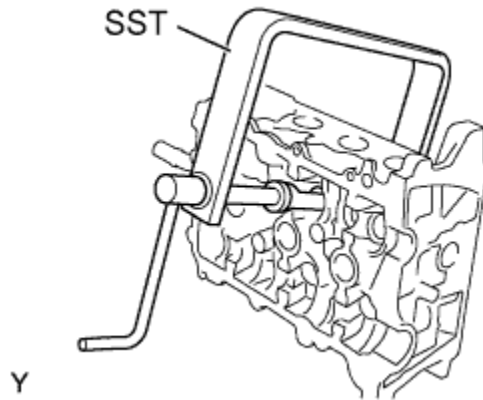

7. Using SST, compress the inner compression springs and place the 2 valve spring retainer locks around the valve stem.

SST
09202-70020

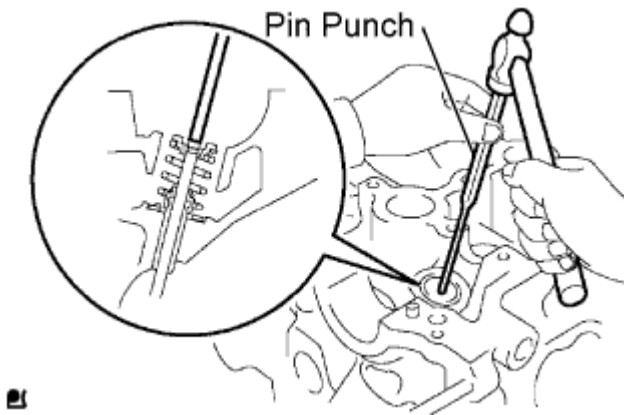

8. Using a pin punch, gently tap the valve stem tip to ensure that it is fitted properly.

NOTICE:
Do not damage the valve stem tip.

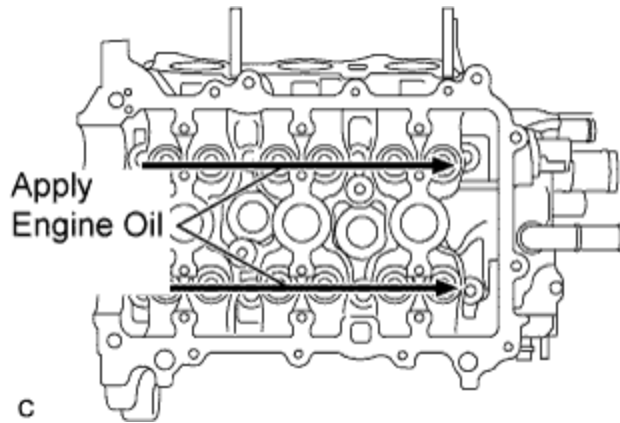

9. Apply engine oil to the top surfaces of the valve as shown in the illustration.

13. INSTALL CYLINDER HEAD GASKET

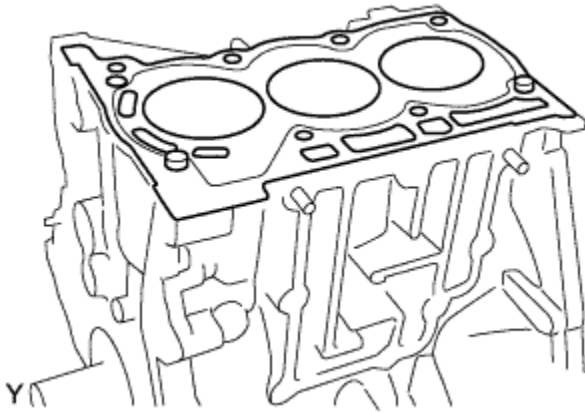

1. Place a new cylinder head gasket on the cylinder block sub-assembly.

14. INSTALL CYLINDER HEAD SUB-ASSEMBLY

NOTICE:

Place the cylinder head gently in order not to damage the gasket.

1. Place the cylinder head on the cylinder block sub-assembly.

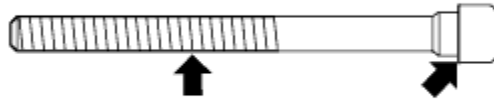

c

2. Apply engine oil to each bolt thread and seating surface.

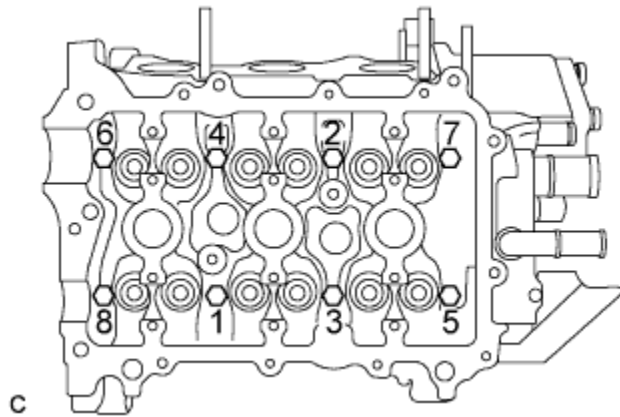

3. Tighten the bolts in 2 or 3 steps in the order shown in the illustration to install the cylinder head sub-assembly.
4. Tighten the bolts to the specified torque (*1).

Torque:

32 N*m { 326 kgf*cm , 24 ft.*lbf }

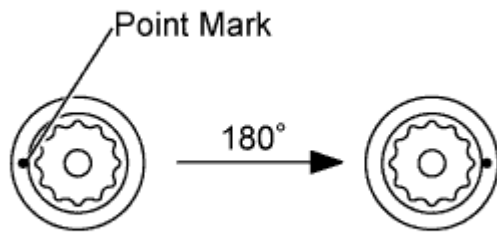

5. Mark the front of each cylinder head bolt with paint.
6. Retighten the bolts by 180° in the order indicated in step (*1).
7. Check that the painted marks are now 180° from the front.

8. Install the 8 stud bolts.

Upper Side:

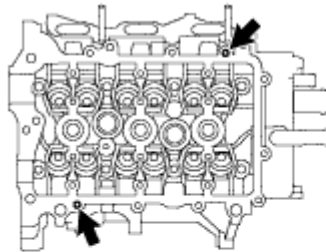

Intake Side:

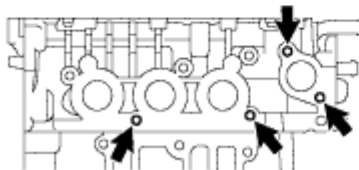

Exhaust Side:

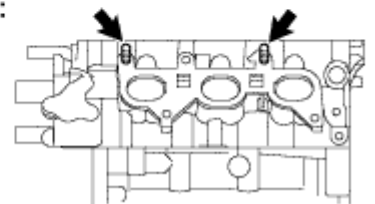

15. INSTALL VALVE LIFTER

1. Apply engine oil to the circumference of the valve lifters.
2. Install the valve lifters straight into the lifter holes.

NOTICE:

Check that the valve lifters turn smoothly after installing them.

16. INSTALL ENGINE REAR OIL SEAL

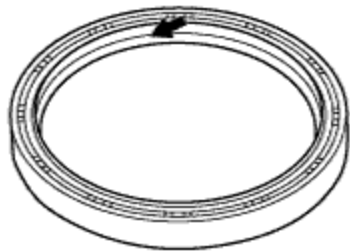

c

1. Apply engine oil to the lip of a new oil seal.
2. Using SST, tap the oil seal straight in.

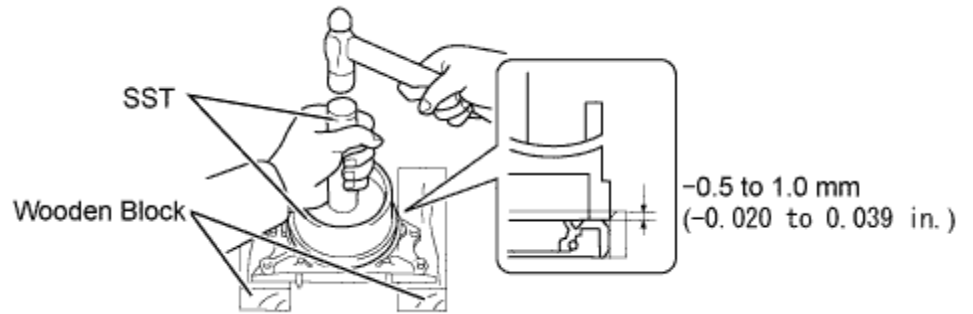

SST

09950-60020 (09951-00890)

09950-70010 (09951-07200)

Correct oil seal position:

Protrusion from rear oil seal retainer edge:

0.5 mm (0.020 in.) or less

Installation depth from rear oil seal retainer edge:

1.0 mm (0.039 in.) or less

17. INSTALL ENGINE REAR OIL SEAL RETAINER

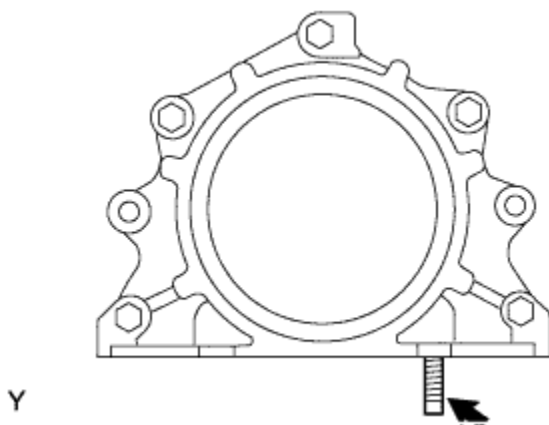

1. Install the stud bolt onto the rear oil seal retainer.

Torque:

4.0 N*m { 41 kgf*cm , 35 in.*lbf }

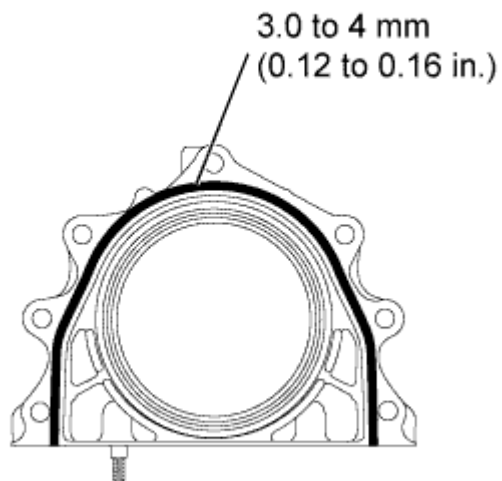

2. Apply a continuous bead of seal packing (Diameter 3 to 4 mm (0.12 to 0.16 in.)) as shown in the illustration.

Seal packing:

Part No. 08826-00080 or the equivalent

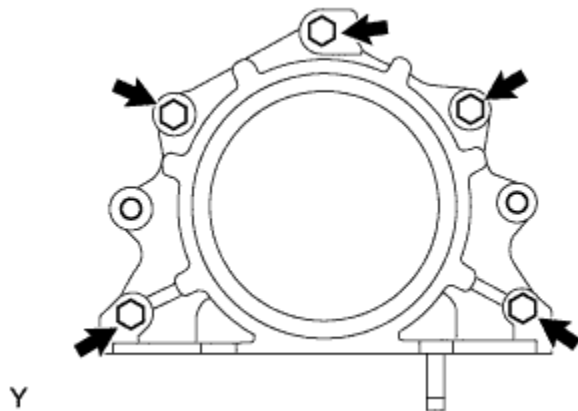

3. Install the oil seal retainer with the 5 bolts.

Torque:
10 N*m { 102 kgf*cm , 7.0 ft.*lbf }

18. INSTALL VENTILATION BAFFLE PLATE

1. Clean the installation surface of the cylinder block sub-assembly and ventilation baffle plate.

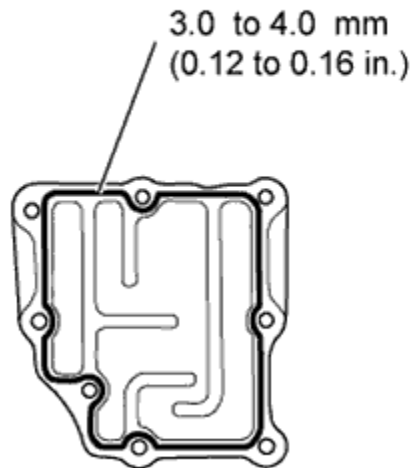

2. Apply a continuous bead of seal packing (Diameter 3 to 4 mm (0.12 to 0.16 in.)) as shown in the illustration.

Seal packing:
Part No. 08826-00080 or the equivalent

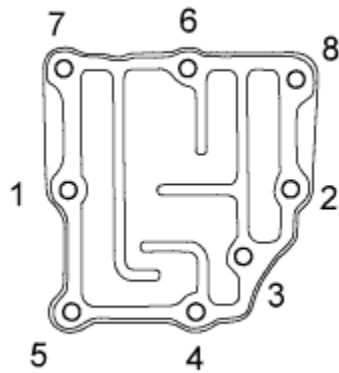

3. Install the ventilation baffle plate in the order shown in the illustration with the 6 bolts and 2 nuts.

Torque:

24 N*m { 245 kgf*cm , 18 ft.*lbf }

NOTICE:

Install the ventilation baffle plate within 3 minutes of applying seal packing.

19. INSTALL CAMSHAFTS

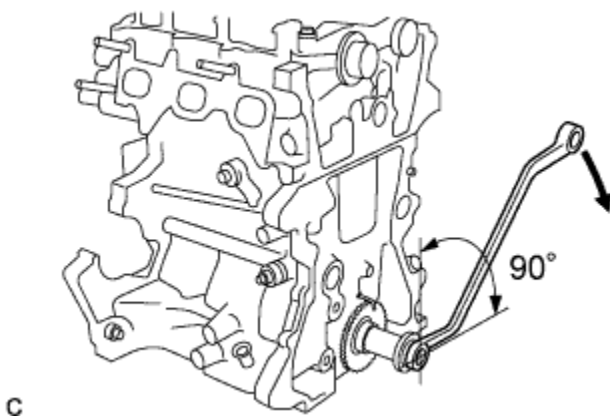

1. Before installing the camshaft, turn the crankshaft approximately 90° in the engine revolution direction from the point where the No. 1 piston is set at the TDC/ compression so that the lifted valve and piston do not touch each other.

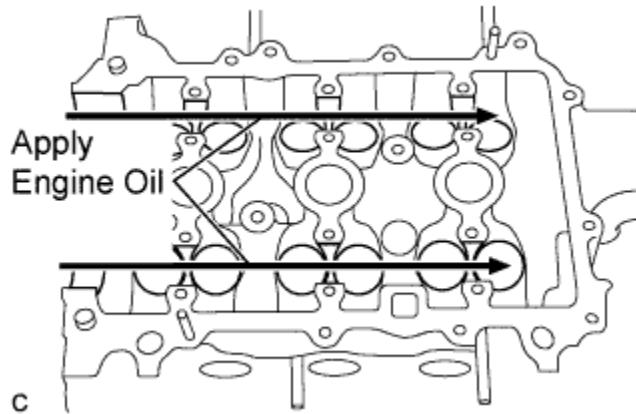

2. Apply engine oil to the contact areas of the cam and journal of the camshafts No. 1 and No. 2.

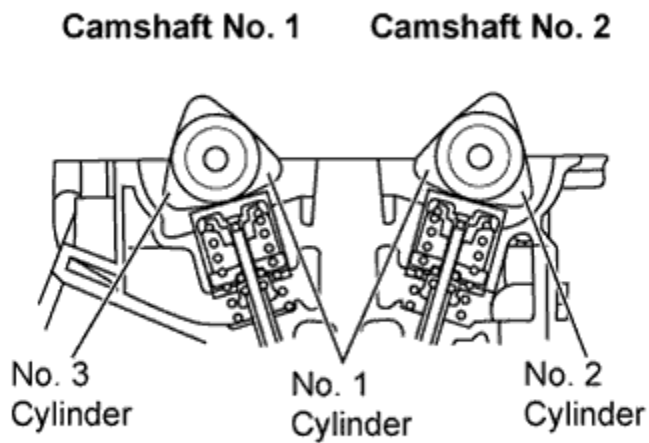

3. Set camshaft assembly No. 1 so that the cam noses for cylinders No. 1 and No. 3 press onto the valve lifters.
4. Set camshaft assembly No. 2 (on the exhaust side) so that the cam noses for cylinders No. 1 and No. 2 press onto the valve lifters.

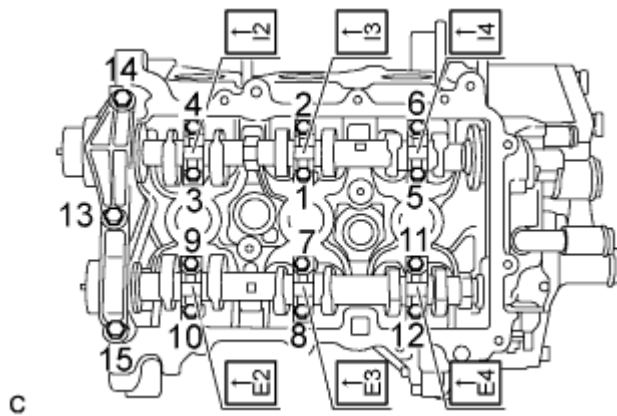

- Set the camshaft bearing caps No. 1 and No. 2 and tighten the bolts in the order shown in the illustration.

Torque:

Camshaft bearing cap No. 1:

15 N*m { 153 kgf*cm , 11 ft.*lbf }

Camshaft bearing cap No. 2:

12.5 N*m { 128 kgf*cm , 9.0 ft.*lbf }

NOTICE:

- Install the bearing caps with the front marks facing the engine front.
- Install the bolts in the correct positions by referring to the numbers inscribed on the bolts and the table below.

| Installation position of the bearing cap No. 2 | |
|--|---------------|
| Installation position | Inscribed No. |
| Intake No. 1 cylinder | I2 |
| Intake No. 2 cylinder | I3 |
| Intake No. 3 cylinder | I4 |
| Exhaust No. 1 cylinder | E2 |
| Exhaust No. 2 cylinder | E3 |
| Exhaust No. 3 cylinder | E4 |

20. INSTALL CAMSHAFT TIMING SPROCKET ASSEMBLY

c

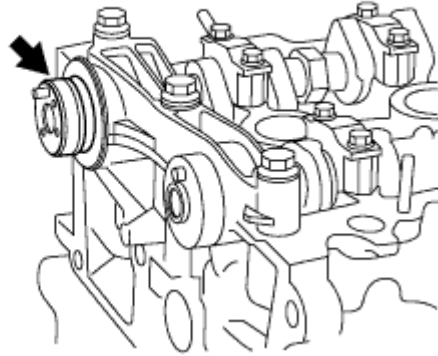

1. Apply engine oil to the camshaft timing sprocket installation portion of the camshaft.
2. Insert the knock pin on the camshaft end into the knock hole in the camshaft timing sprocket.

NOTICE:

- Slightly turn the sprocket to make sure that the knock pin is securely installed after inserting the knock pin.
- The end surface of the sprocket may be damaged if the sprocket is turned with excessive force when the knock pin is not inserted.

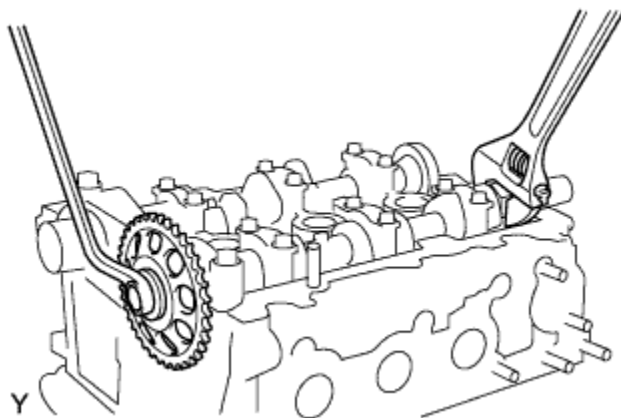

3. While holding the hexagonal portion of the camshaft, tighten the bolts to install the camshaft timing sprocket.

Torque:
47 N*m { 479 kgf*cm , 35 ft.*lbf }

21. INSTALL CAMSHAFT TIMING GEAR OR SPROCKET

1. Insert the camshaft timing gear so that the knock pin on the camshaft end fits into the groove.

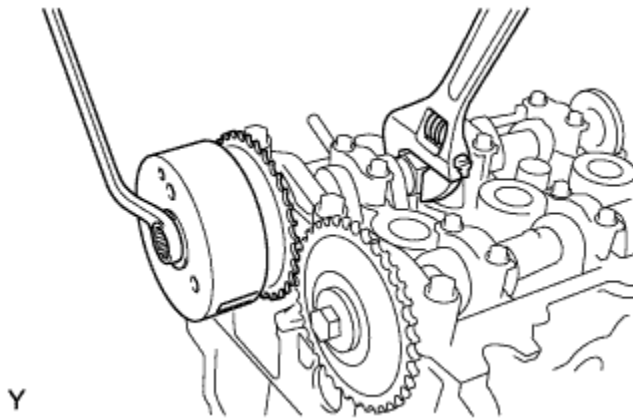

2. While holding the hexagonal portion of the camshaft, tighten the bolts to install the camshaft timing gear.

Torque:
47 N*m { 479 kgf*cm , 35 ft.*lbf }

22. INSPECT VALVE CLEARANCE

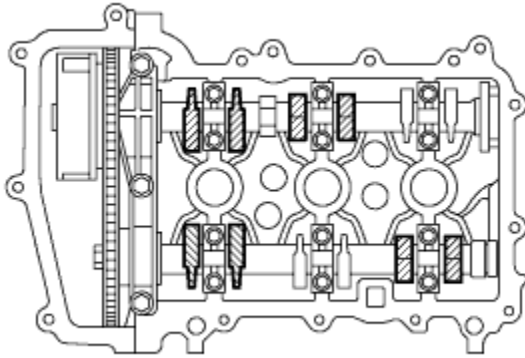

N

1. Check only the valves indicated.

1. Using a feeler gauge, measure the clearance between the valve lifter and camshaft.

Valve clearance (Cold):

Intake side:

0.145 to 0.235 mm (0.00571 to 0.00925 in.)

Exhaust side:

0.275 to 0.365 mm (0.01083 to 0.01437 in.)

HINT:

Insert the feeler gauge from the spark plug side (center).

2. Record any out-of-specification valve clearance measurements. They will be used later to determine the required replacement valve lifters.

2. Turn the crankshaft 1 revolution (360°).

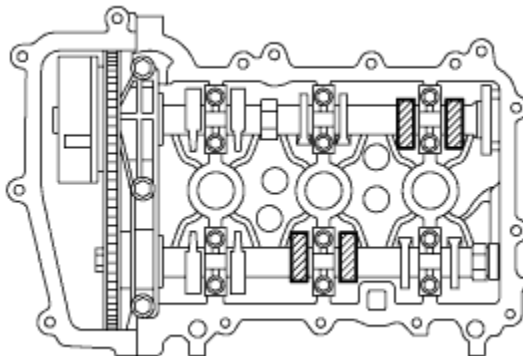

N

3. Check only the valves indicated.

1. Using a feeler gauge, measure the clearance between the valve lifter and camshaft.

Valve clearance (Cold):

Intake side:

0.145 to 0.235 mm (0.00571 to 0.00925 in.)

Exhaust side:

0.275 to 0.365 mm (0.01083 to 0.01437 in.)

HINT:

Insert the feeler gauge from the spark plug side (center).

2. Record any out-of-specification valve clearance measurements. They will be used later to determine the required replacement valve lifters.

23. ADJUST VALVE CLEARANCE

1. Remove the No. 1 and No. 2 camshafts ().
2. Remove the valve lifters ().

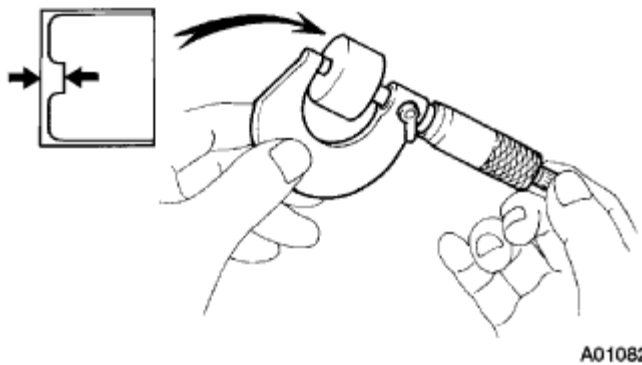

3. Using a micrometer, measure the thickness of the removed valve lifters.
4. Calculate the thickness of a new lifter so that the valve clearance comes within the specified value.

Valve Lifter Selection Chart (Intake)

| Measured Clearance mm (in.) | Installed Lifter Thickness mm (in.) | | | | | | | | | | | | | | | | |
|---------------------------------|--|----|----|----|----|----|----|----|----|----|----|----|----|----|----|----|----------------|
| | | 18 | 20 | 22 | 24 | 26 | 28 | 30 | 32 | 34 | 36 | 38 | 40 | 42 | 44 | 46 | |
| 0.000 - 0.030 (0.0000 - 0.0012) | | | | | | | | | | | | | | | | | 5.120 (0.2016) |
| 0.031 - 0.050 (0.0012 - 0.0020) | | | | | | | | | | | | | | | | | 5.140 (0.2024) |
| 0.051 - 0.070 (0.0020 - 0.0028) | | | | | | | | | | | | | | | | | 5.160 (0.2031) |
| 0.071 - 0.090 (0.0028 - 0.0035) | | | | | | | | | | | | | | | | | 5.180 (0.2039) |
| 0.091 - 0.110 (0.0036 - 0.0043) | | | | | | | | | | | | | | | | | 5.200 (0.2047) |
| 0.111 - 0.130 (0.0044 - 0.0051) | | | | | | | | | | | | | | | | | 5.210 (0.2051) |
| 0.131 - 0.149 (0.0052 - 0.0059) | | | | | | | | | | | | | | | | | 5.220 (0.2055) |
| 0.150 - 0.250 (0.0059 - 0.0098) | | | | | | | | | | | | | | | | | 5.230 (0.2059) |
| 0.251 - 0.270 (0.0099 - 0.0106) | | | | | | | | | | | | | | | | | 5.240 (0.2063) |
| 0.271 - 0.290 (0.0107 - 0.0114) | | | | | | | | | | | | | | | | | 5.250 (0.2067) |
| 0.291 - 0.310 (0.0115 - 0.0122) | | | | | | | | | | | | | | | | | 5.260 (0.2071) |
| 0.311 - 0.330 (0.0122 - 0.0130) | | | | | | | | | | | | | | | | | 5.270 (0.2075) |
| 0.331 - 0.350 (0.0130 - 0.0138) | | | | | | | | | | | | | | | | | 5.280 (0.2079) |
| 0.351 - 0.370 (0.0138 - 0.0146) | | | | | | | | | | | | | | | | | 5.290 (0.2083) |
| 0.371 - 0.390 (0.0146 - 0.0154) | | | | | | | | | | | | | | | | | 5.300 (0.2087) |
| 0.391 - 0.410 (0.0154 - 0.0161) | | | | | | | | | | | | | | | | | 5.310 (0.2091) |
| 0.411 - 0.430 (0.0162 - 0.0169) | | | | | | | | | | | | | | | | | 5.320 (0.2094) |
| 0.431 - 0.450 (0.0170 - 0.0177) | | | | | | | | | | | | | | | | | 5.330 (0.2098) |
| 0.451 - 0.470 (0.0178 - 0.0185) | | | | | | | | | | | | | | | | | 5.340 (0.2102) |
| 0.471 - 0.490 (0.0185 - 0.0193) | | | | | | | | | | | | | | | | | 5.350 (0.2106) |
| 0.491 - 0.510 (0.0193 - 0.0201) | | | | | | | | | | | | | | | | | 5.360 (0.2110) |
| 0.511 - 0.530 (0.0201 - 0.0209) | | | | | | | | | | | | | | | | | 5.370 (0.2114) |
| 0.531 - 0.550 (0.0209 - 0.0217) | | | | | | | | | | | | | | | | | 5.380 (0.2118) |
| 0.551 - 0.570 (0.0217 - 0.0224) | | | | | | | | | | | | | | | | | 5.390 (0.2122) |
| 0.571 - 0.590 (0.0225 - 0.0232) | | | | | | | | | | | | | | | | | 5.400 (0.2126) |
| 0.591 - 0.610 (0.0233 - 0.0240) | | | | | | | | | | | | | | | | | 5.410 (0.2130) |
| 0.611 - 0.630 (0.0241 - 0.0248) | | | | | | | | | | | | | | | | | 5.420 (0.2134) |
| 0.631 - 0.650 (0.0248 - 0.0256) | | | | | | | | | | | | | | | | | 5.430 (0.2138) |
| 0.651 - 0.670 (0.0256 - 0.0264) | | | | | | | | | | | | | | | | | 5.440 (0.2142) |
| 0.671 - 0.690 (0.0264 - 0.0272) | | | | | | | | | | | | | | | | | 5.450 (0.2146) |
| 0.691 - 0.710 (0.0272 - 0.0280) | | | | | | | | | | | | | | | | | 5.460 (0.2150) |
| 0.711 - 0.730 (0.0280 - 0.0287) | | | | | | | | | | | | | | | | | 5.470 (0.2154) |
| 0.731 - 0.750 (0.0288 - 0.0295) | | | | | | | | | | | | | | | | | 5.480 (0.2157) |
| 0.751 - 0.770 (0.0296 - 0.0303) | | | | | | | | | | | | | | | | | 5.490 (0.2161) |
| | | | | | | | | | | | | | | | | | 5.500 (0.2165) |
| | | | | | | | | | | | | | | | | | 5.510 (0.2169) |
| | | | | | | | | | | | | | | | | | 5.520 (0.2173) |
| | | | | | | | | | | | | | | | | | 5.530 (0.2177) |
| | | | | | | | | | | | | | | | | | 5.540 (0.2181) |
| | | | | | | | | | | | | | | | | | 5.550 (0.2185) |
| | | | | | | | | | | | | | | | | | 5.560 (0.2189) |
| | | | | | | | | | | | | | | | | | 5.570 (0.2193) |
| | | | | | | | | | | | | | | | | | 5.580 (0.2197) |
| | | | | | | | | | | | | | | | | | 5.590 (0.2201) |
| | | | | | | | | | | | | | | | | | 5.600 (0.2205) |
| | | | | | | | | | | | | | | | | | 5.620 (0.2213) |
| | | | | | | | | | | | | | | | | | 5.640 (0.2220) |
| | | | | | | | | | | | | | | | | | 5.660 (0.2228) |
| | | | | | | | | | | | | | | | | | 5.680 (0.2236) |

Valve Lifter Selection Chart (Exhaust)

| | | Measured Clearance mm (in.) | Installed Lifter Thickness mm (in.) |
|--|--|---------------------------------|--|
| | | 0.000 - 0.030 (0.0000 - 0.0012) | 5.120 (0.2018) |
| | | 0.031 - 0.050 (0.0012 - 0.0020) | 5.140 (0.2024) |
| | | 0.051 - 0.070 (0.0020 - 0.0028) | 5.160 (0.2031) |
| | | 0.071 - 0.090 (0.0028 - 0.0035) | 5.180 (0.2039) |
| | | 0.091 - 0.110 (0.0035 - 0.0043) | 5.200 (0.2047) |
| | | 0.111 - 0.130 (0.0043 - 0.0051) | 5.220 (0.2055) |
| | | 0.131 - 0.150 (0.0052 - 0.0059) | 5.230 (0.2059) |
| | | 0.151 - 0.170 (0.0059 - 0.0067) | 5.240 (0.2063) |
| | | 0.171 - 0.190 (0.0067 - 0.0075) | 5.250 (0.2067) |
| | | 0.191 - 0.210 (0.0075 - 0.0083) | 5.260 (0.2071) |
| | | 0.211 - 0.230 (0.0083 - 0.0091) | 5.270 (0.2075) |
| | | 0.231 - 0.249 (0.0091 - 0.0098) | 5.280 (0.2079) |
| | | 0.250 - 0.269 (0.0098 - 0.0106) | 5.290 (0.2083) |
| | | 0.269 - 0.287 (0.0106 - 0.0114) | 5.300 (0.2087) |
| | | 0.288 - 0.306 (0.0114 - 0.0122) | 5.310 (0.2091) |
| | | 0.307 - 0.325 (0.0122 - 0.0130) | 5.320 (0.2094) |
| | | 0.326 - 0.344 (0.0130 - 0.0138) | 5.330 (0.2098) |
| | | 0.345 - 0.363 (0.0138 - 0.0146) | 5.340 (0.2102) |
| | | 0.364 - 0.382 (0.0146 - 0.0154) | 5.350 (0.2106) |
| | | 0.383 - 0.401 (0.0154 - 0.0162) | 5.360 (0.2110) |
| | | 0.402 - 0.420 (0.0162 - 0.0169) | 5.370 (0.2114) |
| | | 0.421 - 0.439 (0.0169 - 0.0177) | 5.380 (0.2118) |
| | | 0.440 - 0.458 (0.0177 - 0.0185) | 5.390 (0.2122) |
| | | 0.459 - 0.477 (0.0185 - 0.0193) | 5.400 (0.2126) |
| | | 0.478 - 0.496 (0.0193 - 0.0201) | 5.410 (0.2130) |
| | | 0.497 - 0.515 (0.0201 - 0.0209) | 5.420 (0.2134) |
| | | 0.516 - 0.534 (0.0209 - 0.0217) | 5.430 (0.2138) |
| | | 0.535 - 0.553 (0.0217 - 0.0224) | 5.440 (0.2142) |
| | | 0.554 - 0.572 (0.0224 - 0.0232) | 5.450 (0.2146) |
| | | 0.573 - 0.591 (0.0232 - 0.0240) | 5.460 (0.2150) |
| | | 0.592 - 0.610 (0.0240 - 0.0248) | 5.470 (0.2154) |
| | | 0.611 - 0.629 (0.0248 - 0.0256) | 5.480 (0.2157) |
| | | 0.630 - 0.648 (0.0256 - 0.0264) | 5.490 (0.2161) |
| | | 0.649 - 0.667 (0.0264 - 0.0272) | 5.500 (0.2165) |
| | | 0.668 - 0.686 (0.0272 - 0.0280) | 5.510 (0.2169) |
| | | 0.687 - 0.705 (0.0280 - 0.0287) | 5.520 (0.2173) |
| | | 0.706 - 0.724 (0.0287 - 0.0295) | 5.530 (0.2177) |
| | | 0.725 - 0.743 (0.0295 - 0.0303) | 5.540 (0.2181) |
| | | 0.744 - 0.762 (0.0303 - 0.0311) | 5.550 (0.2185) |
| | | 0.763 - 0.781 (0.0311 - 0.0319) | 5.560 (0.2189) |
| | | 0.782 - 0.800 (0.0319 - 0.0327) | 5.570 (0.2193) |
| | | 0.801 - 0.819 (0.0327 - 0.0335) | 5.580 (0.2197) |
| | | 0.820 - 0.838 (0.0335 - 0.0343) | 5.590 (0.2201) |
| | | | 5.600 (0.2205) |
| | | | 5.620 (0.2213) |
| | | | 5.640 (0.2220) |
| | | | 5.660 (0.2228) |
| | | | 5.680 (0.2236) |

HINT:

| New lifter thickness mm (in.) | | | | | |
|-------------------------------|---------------|------------|---------------|------------|---------------|
| Lifter No. | Thickness | Lifter No. | Thickness | Lifter No. | Thickness |
| 12 | 5.12 (0.2016) | 32 | 5.32 (0.2094) | 52 | 5.52 (0.2173) |
| 14 | 5.14 (0.2024) | 34 | 5.34 (0.2102) | 54 | 5.54 (0.2181) |
| 16 | 5.16 (0.2031) | 36 | 5.36 (0.2110) | 56 | 5.56 (0.2189) |
| 18 | 5.18 (0.2039) | 38 | 5.38 (0.2118) | 58 | 5.58 (0.2197) |
| 20 | 5.20 (0.2047) | 40 | 5.40 (0.2126) | 60 | 5.60 (0.2205) |
| 22 | 5.22 (0.2055) | 42 | 5.42 (0.2134) | 62 | 5.62 (0.2213) |
| 24 | 5.24 (0.2063) | 44 | 5.44 (0.2142) | 64 | 5.64 (0.2220) |
| 26 | 5.26 (0.2071) | 46 | 5.46 (0.2150) | 66 | 5.66 (0.2228) |
| 28 | 5.28 (0.2079) | 48 | 5.48 (0.2157) | 68 | 5.68 (0.2236) |
| 30 | 5.30 (0.2087) | 50 | 5.50 (0.2165) | - | - |

24. INSTALL OIL JET

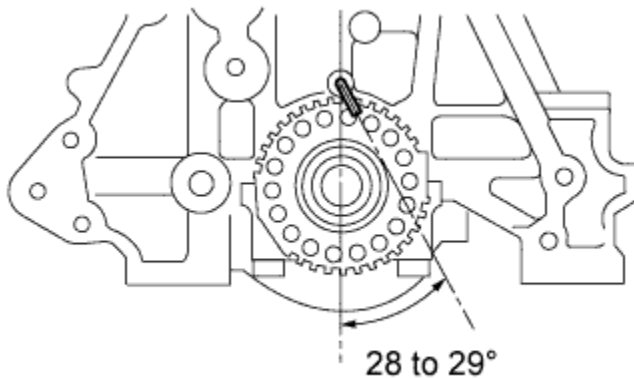

Y

10. Install the oil jet as shown in the illustration.

NOTICE:
Insert the oil jet until the spool is attached.

25. INSTALL CRANKSHAFT STRAIGHT PIN

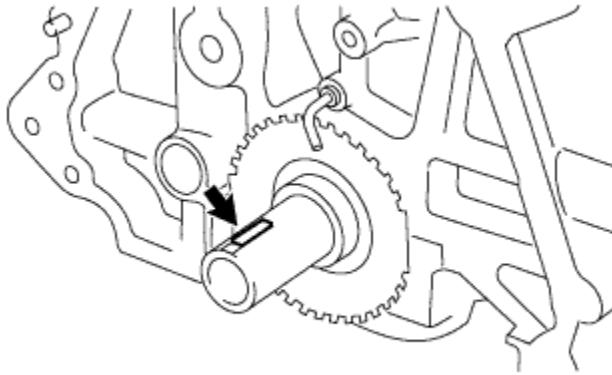

Y

11. Install the crankshaft straight pin into the crankshaft groove.

26. INSTALL CRANKSHAFT TIMING GEAR OR SPROCKET

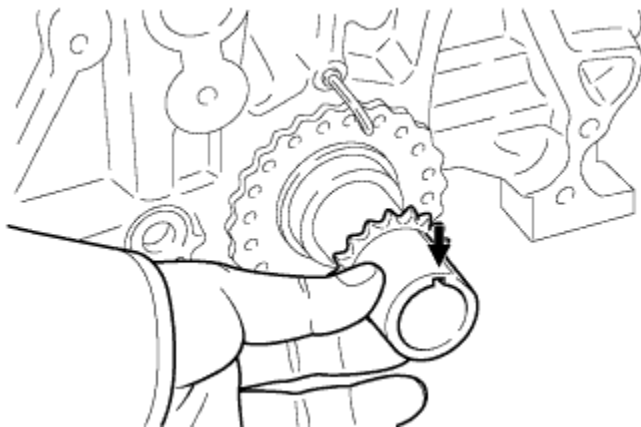

2. Align the groove of the crankshaft timing sprocket with the key of the crankshaft and install the crankshaft timing sprocket.

27. INSTALL TIMING CHAIN GUIDE

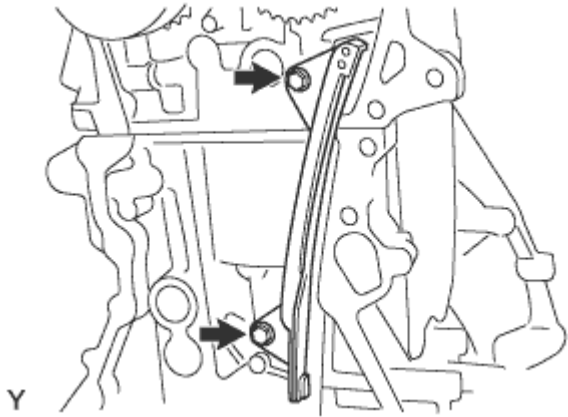

3. Install the timing chain guide with the 2 bolts.
Torque:
9.0 N*m { 92 kgf*cm , 80 in.*lbf }

28. INSTALL CHAIN SUB-ASSEMBLY

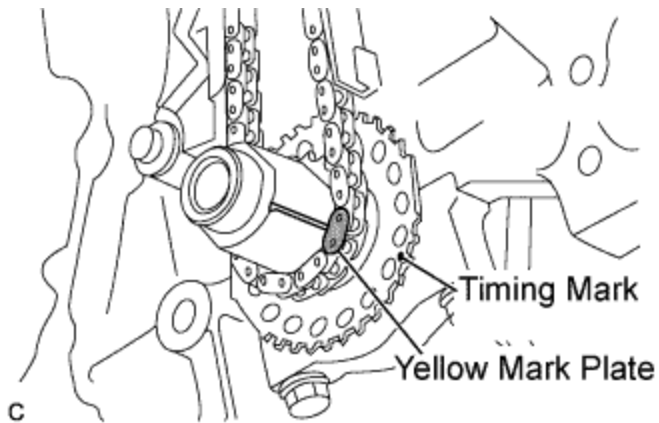

2. Align the yellow mark plate with the timing mark of the crankshaft timing sprocket and install the timing chain, as shown in the illustration.

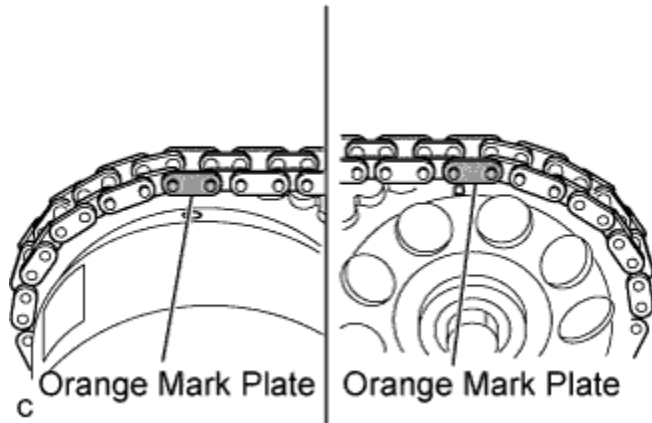

2. Align the 2 orange mark plates with the timing marks of the camshaft timing sprockets and install the timing chain, as shown in the illustration.

29. INSTALL TIMING CHAIN TENSION ARM

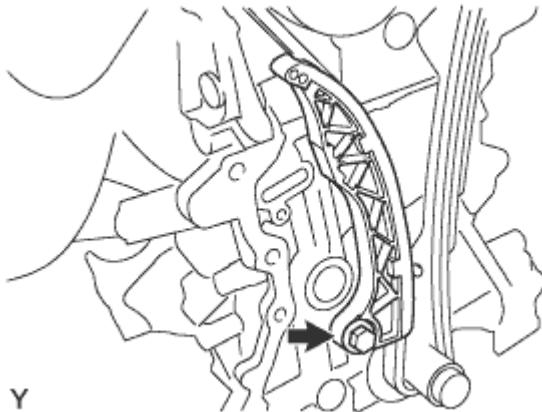

3. Install the timing chain tension arm with the bolt.
Torque:
19 N*m { 194 kgf*cm , 14 ft.*lbf }

30. INSTALL CHAIN TENSIONER ASSEMBLY NO. 1

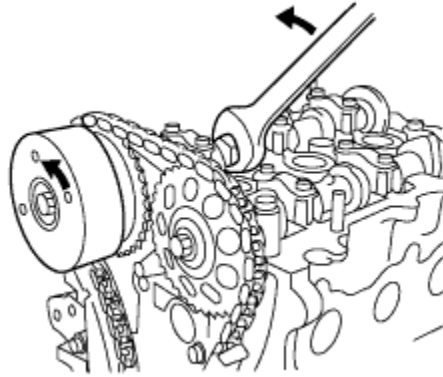

C

2. Slightly turn the hexagonal portion of the camshaft assembly (intake side) counterclockwise to leave some slack on the chain of the timing chain tensioner side.

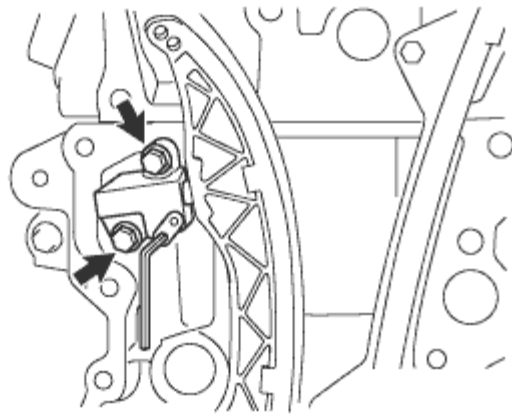

Y

3. Install the chain tensioner with the 2 bolts.
Torque:
 $10.5 \text{ N}\cdot\text{m} \{ 107 \text{ kgf}\cdot\text{cm} , 8.0 \text{ ft}\cdot\text{lb} \}$
2. Remove the hexagon wrench, turn the crankshaft 2 complete revolutions and operate the chain tension assembly.

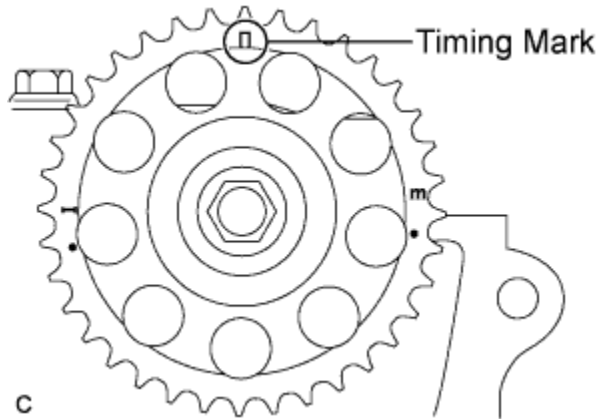

2. Make sure that the timing mark of the sprocket camshaft timing is at the top with the timing chain tensed (set No. 1 piston to the TDC/ compression).

31. INSTALL OIL PUMP GASKET

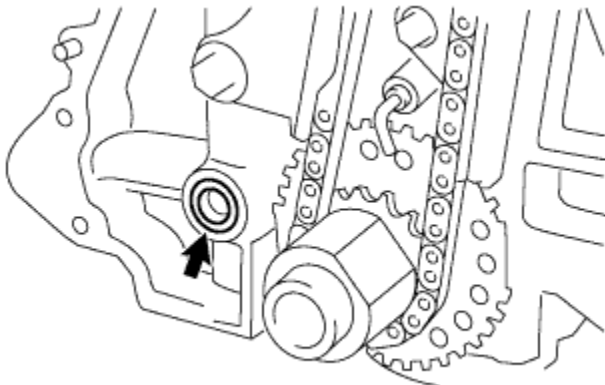

Y

3. Install a new oil pump gasket onto the cylinder block.

32. INSTALL TIMING CHAIN OR BELT COVER OIL SEAL

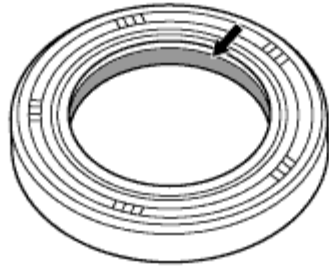

C

2. Apply engine oil to the lip of a new oil seal.

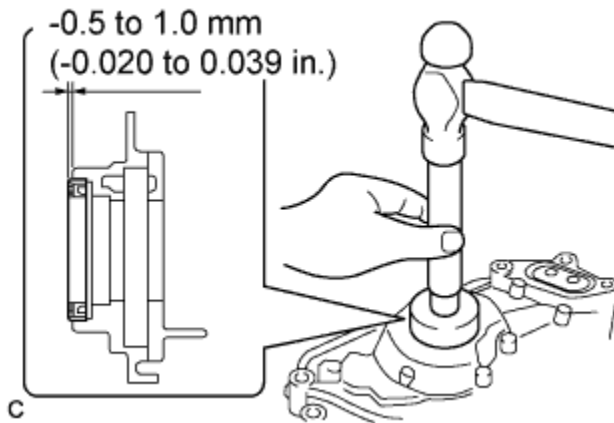

C

3. Using SST, tap the oil seal straight in.
SST
09950-60010 (09951-00500, 09952-06010)
09950-70010 (09951-07200)
Correct oil seal position:
Protrusion from chain cover edge:
0.5 mm (0.020 in.) or less
Installation depth from chain cover edge:
1.0 mm (0.039 in.) or less

33. INSTALL TIMING CHAIN OR BELT COVER SUB-ASSEMBLY

4. Remove any grease from the installation surfaces of the cylinder block sub-assembly and timing chain cover assembly.

- Apply seal packing to the cylinder block and timing chain cover, as shown in the illustration, and install the timing chain cover sub-assembly.

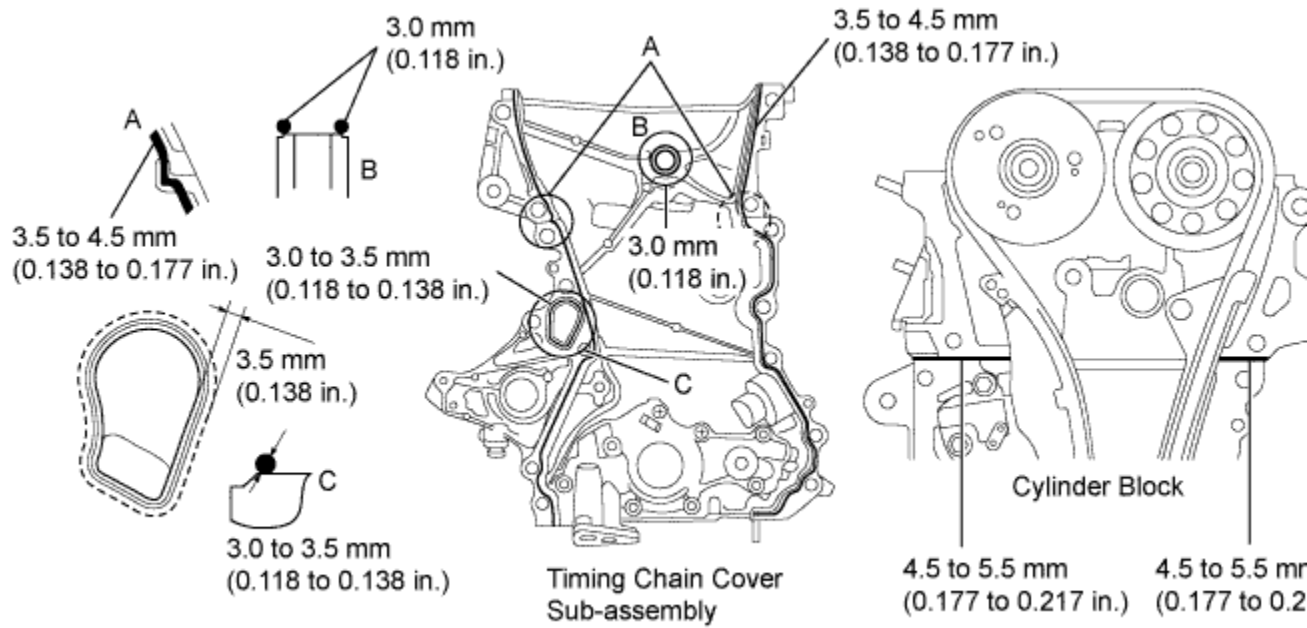

c

Seal packing:

Water pump part:

Part No. 08826-00100 or the equivalent

Other part:

Part No. 08826-00080 or the equivalent

NOTICE:

Install the timing chain cover within 3 minutes of applying seal packing.

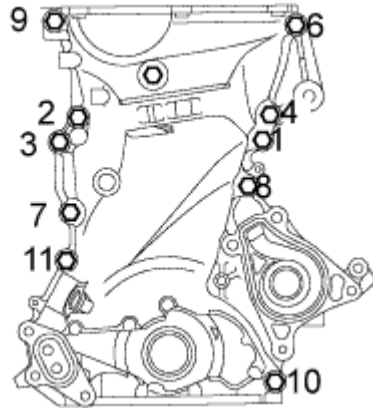

6. Tighten the 11 bolts in the order shown in the illustration.
Torque:
M8 head bolt:
24 N*m { 245 kgf*cm , 18 ft.*lbf }
M10 head bolt:
40 N*m { 408 kgf*cm , 30 ft.*lbf }
7. Remove excess seal packing.

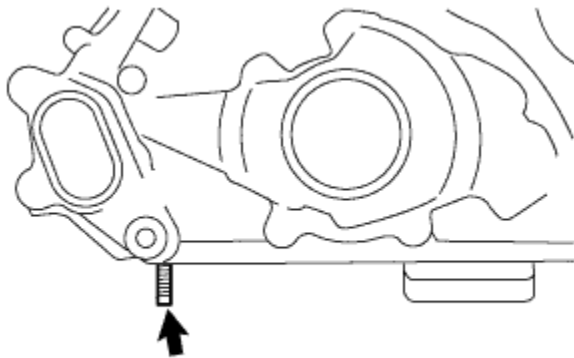

Y

2. Install the stud bolt.

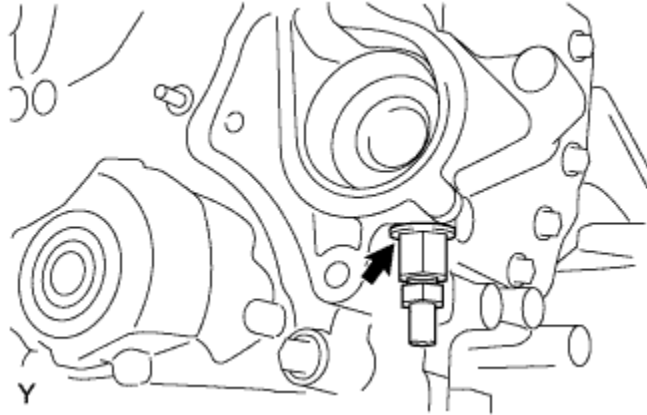

2. Install the water drain plug with a new gasket.
Torque:
54 N*m { 551 kgf*cm , 40 ft.*lbf }

34. INSTALL TIMING GEAR COVER TIGHT PLUG



Y

3. Clean the timing gear cover tight plug and installation surface of the timing chain cover.
4. Apply a light coat of the seal packing black to the timing gear cover tight plug.

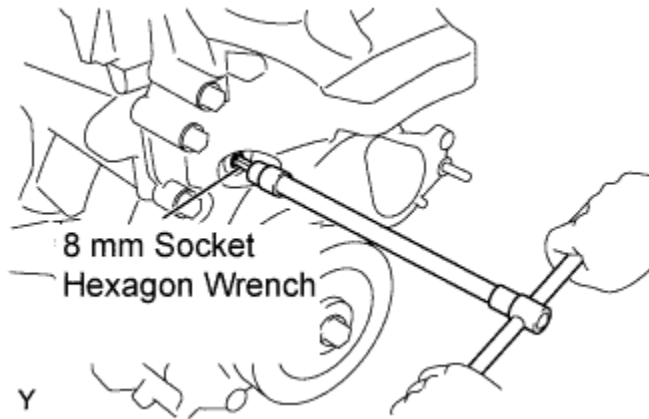

5. Using an 8 mm socket hexagon wrench, install the timing gear cover tight plug onto the timing chain cover.

Torque:

15 N*m { 153 kgf*cm , 11 ft.*lbf }

35. INSTALL CRANKSHAFT PULLEY

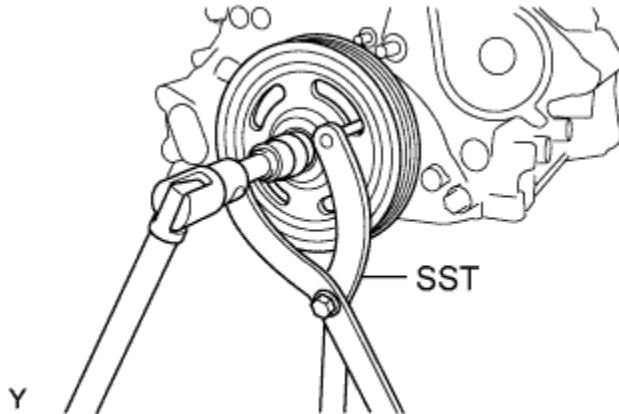

6. Hold the crankshaft pulley with SST and tighten the bolt.

SST

09960-10010 (09962-01000, 09963-01000)

Torque:

170 N*m { 1,734 kgf*cm , 125 ft.*lbf }

36. INSTALL OIL FILTER BRACKET

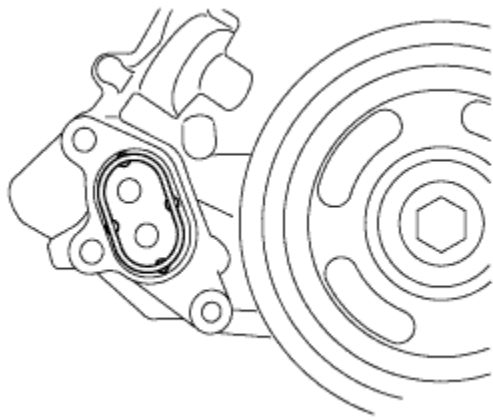

Y

7. Install the gasket onto the timing chain cover.

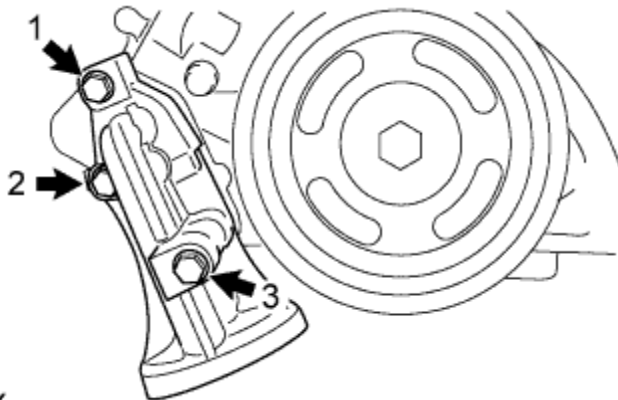

Y

8. Install the oil filter bracket with the 3 bolts.
9. Tighten the 3 bolts in the order shown in the illustration.

Torque:

24 N*m { 245 kgf*cm , 18 ft.*lbf }

37. INSTALL OIL FILTER SUB-ASSEMBLY

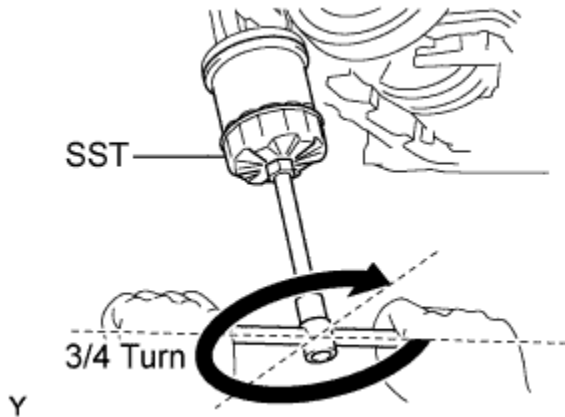

10. Check and clean the oil filter installation surface.
11. Apply clean engine oil to the gasket of a new oil filter.
2. Gently screw the oil filter into place, then tighten it until the gasket comes into contact with the seat.
3. Using SST, tighten it an additional 3/4 turn.

SST
09228-06501

38. INSTALL WATER PUMP ASSEMBLY

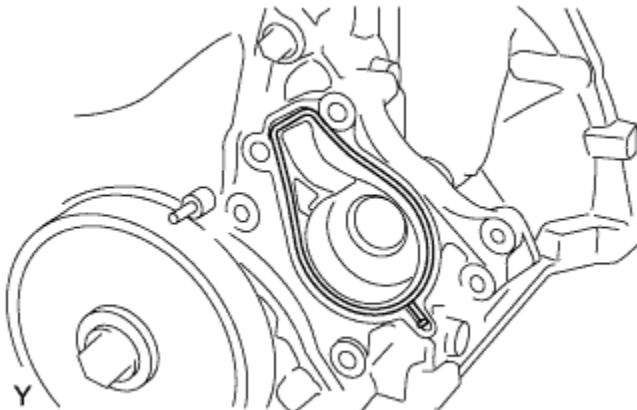

4. Install the gasket onto the chain cover.

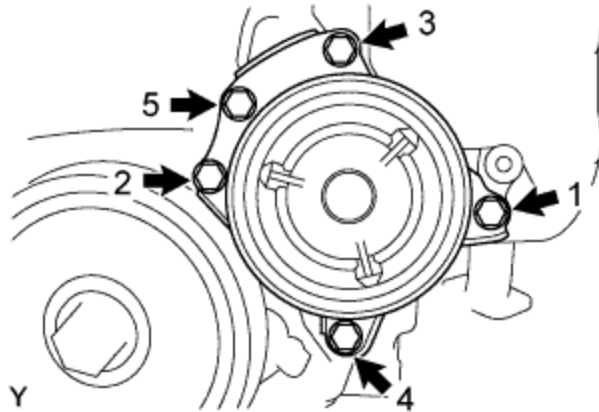

5. Provisionally tighten the water pump with the 5 bolts.
2. Tighten the water pump with the 5 bolts.

Torque:

28 N*m { 286 kgf*cm , 21 ft.*lbf }

NOTICE:

Tighten the bolts and nuts in the sequence shown in the illustration.

39. CONNECT WATER BY-PASS HOSE

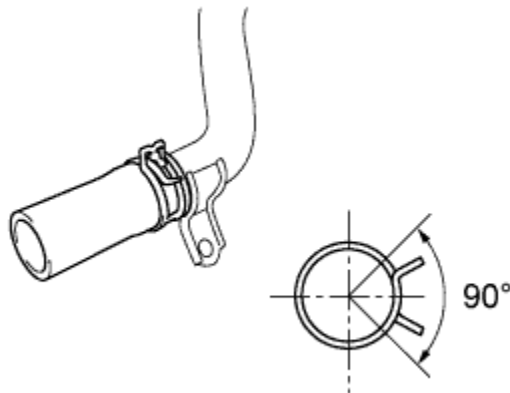

Y

40. INSTALL WATER BY-PASS PIPE NO. 1

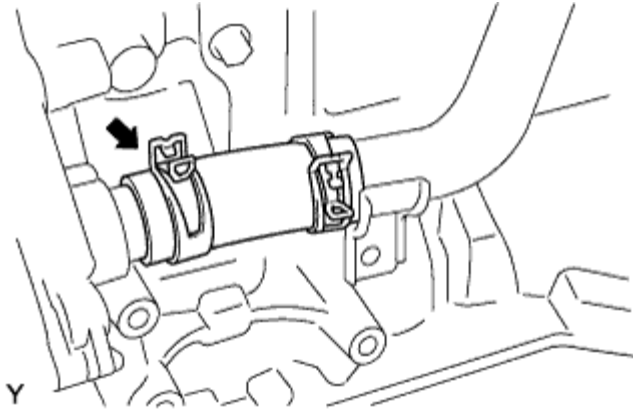

3. Install the water by-pass hose onto the water by-pass pipe with the clamp.
NOTICE:

1. Install the clip as shown in the illustration.
2. Insert the water by-pass hose into the stay edge of the water by-pass hose.

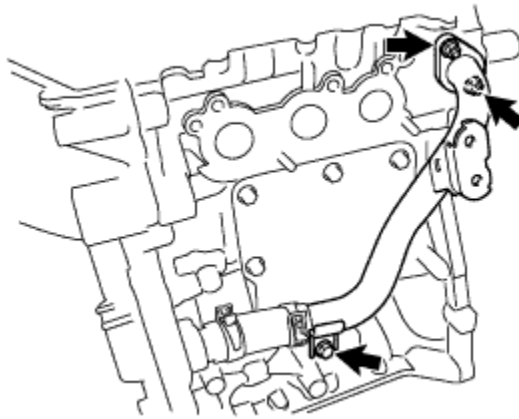

2. Install a new water by-pass pipe gasket and water by-pass pipe No. 1 with the 2 nuts.

Torque:

24 N*m { 245 kgf*cm , 18 ft.*lbf }

NOTICE:

Install the gasket in the direction shown in the illustration.

3. Install the water by-pass pipe with the bolt.

Torque:

24 N*m { 245 kgf*cm , 18 ft.*lbf }

41. INSTALL THERMOSTAT

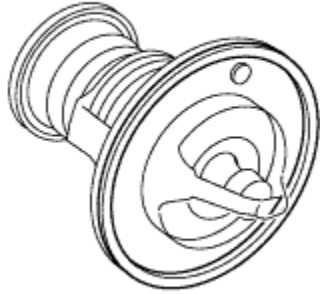

Y

4. Install a new gasket onto the thermostat.

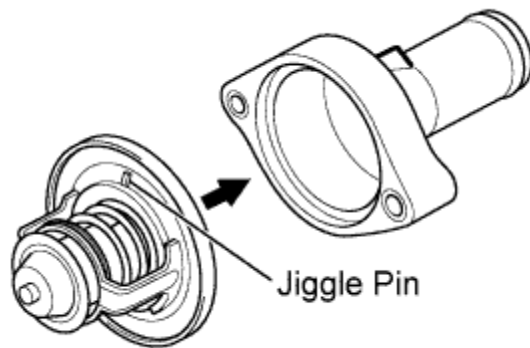

Y

5. Install the thermostat into the water inlet with the jiggle pin facing straight upward.

42. INSTALL WATER INLET

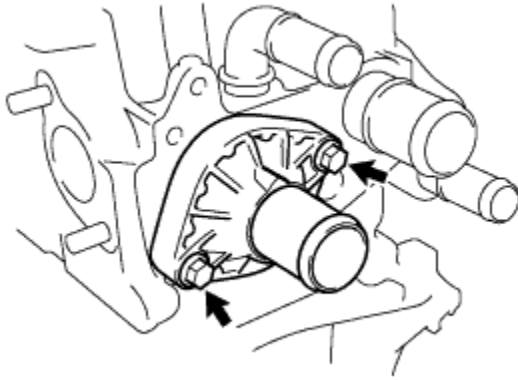

N

6. Install the water inlet with the 2 bolts.

Torque:

7.0 N*m { 71 kgf*cm , 62 in.*lbf }

NOTICE:

1. Avoid catching the rubber gasket of thermostat under the water inlet.
2. Do not use a water inlet that has been dropped.
3. Ensure that gasket is secured between the water inlet and block.

43. INSTALL OIL STRAINER SUB-ASSEMBLY

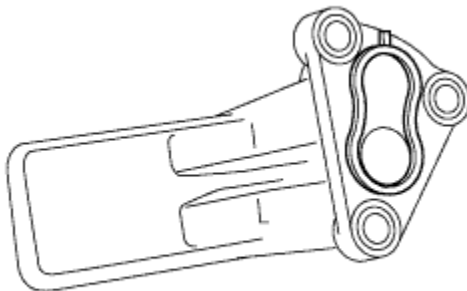

Y

7. Install a new oil strainer gasket onto the oil strainer.

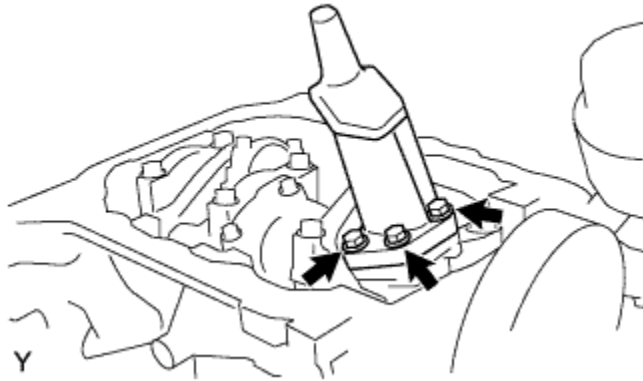

2. Install the oil strainer with the 3 bolts.
Torque:
8.5 N*m { 87 kgf*cm , 75 in.*lbf }

44. INSTALL OIL PAN SUB-ASSEMBLY

3. Remove any grease from the installation surfaces of the cylinder block sub-assembly and oil pan sub-assembly.

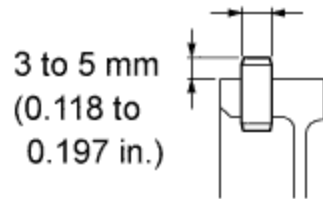
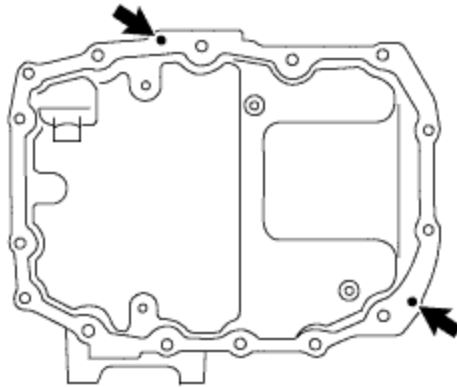

Y

2. Using a plastic hammer, tap into the straight pin, as shown in the illustration.
Standard protrusion:
3 to 5 mm (0.11811 to 0.19685 in.)

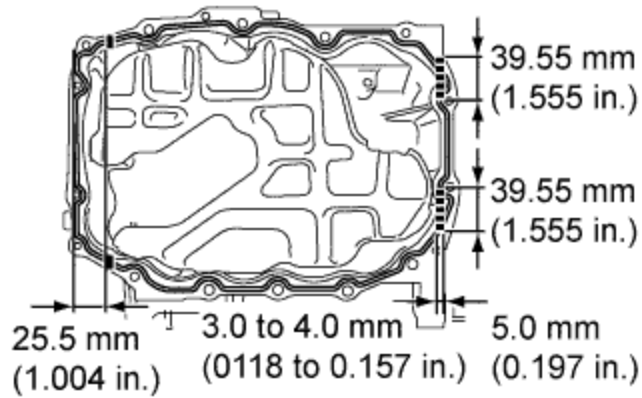

— Contact surface between timing chain cover and cylinder block.

----- Contact surface between oil seal retainer and cylinder block.

3. Apply seal packing to the oil pan sub-assembly and install it onto the cylinder block assembly.

Seal packing:

Part No. 08826-00080 or the equivalent

NOTICE:

1. During sealant application, apply the quantity of sealant specified in the directions and overlap the starting and finished points.
2. Apply seal packing to the contact surfaces between the timing chain cover and cylinder block, and between the oil seal retainer and cylinder block.
3. Install the oil pan sub-assembly within 3 minutes and tighten the bolts within 15 minutes of applying seal packing.

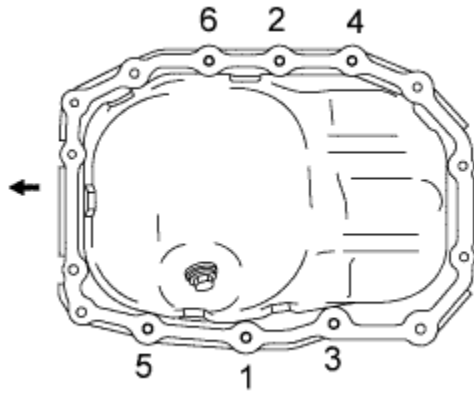

4. Tighten the specified 6 bolts in the order shown in the illustration.
 Torque:
 24 N*m { 245 kgf*cm , 18 ft.*lbf }

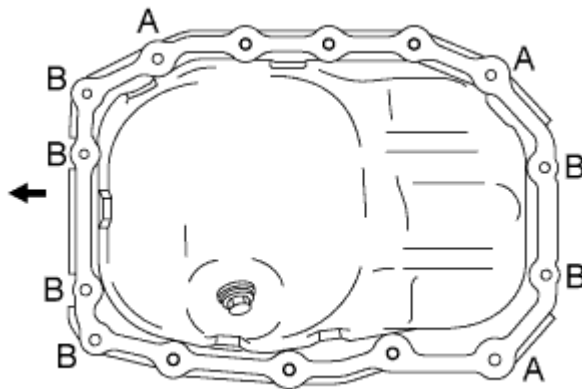

c

2. The remaining 7 bolts and 2 nuts can be tightened in any order.
 Torque:
 A:
 24 N*m { 245 kgf*cm , 18 ft.*lbf }
 B:
 10 N*m { 102 kgf*cm , 7.0 ft.*lbf }

45. INSTALL OIL PAN DRAIN PLUG

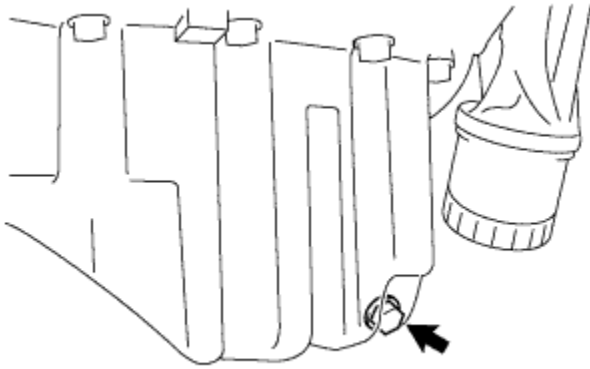

Y

3. Install the engine oil drain plug with a new gasket.
Torque:
30 N*m { 306 kgf*cm , 22 ft.*lbf }

46. INSTALL VENTILATION VALVE SUB-ASSEMBLY

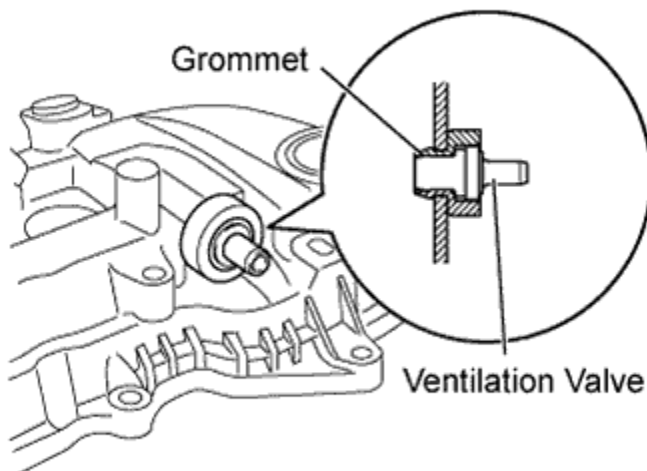

Y

4. Install the grommet, as shown in the illustration.
2. Install the ventilation valve.

47. INSTALL CYLINDER HEAD COVER SUB-ASSEMBLY

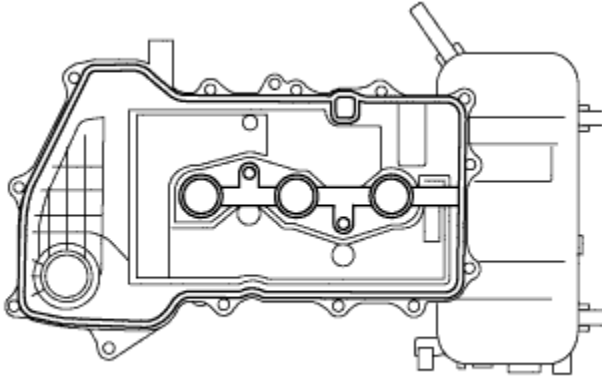

Y

2. Fit the cylinder head cover gasket into the groove on the cylinder head cover and onto the center bosses.

NOTICE:

Insert the gasket securely until it completely fits into the roots of the bosses.

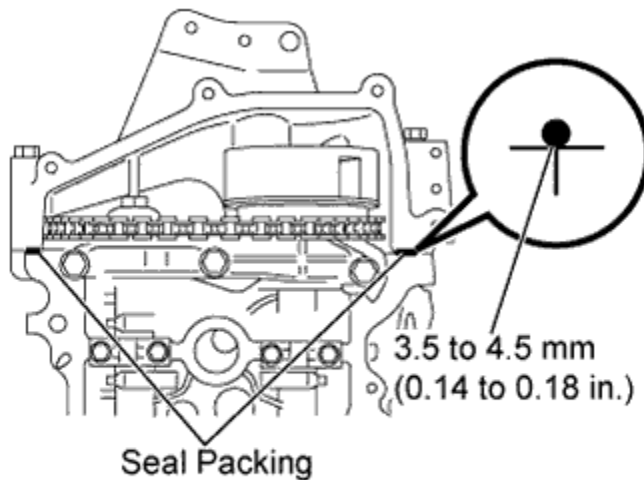

3. Apply seal packing to the upper section of the contact surfaces of the cylinder head sub-assembly and timing chain cover.

Seal packing:

Part No. 08826-00080 or the equivalent

NOTICE:

Install the cylinder head cover within 3 minutes and tighten the bolts and nuts within 15 minutes of applying seal packing.

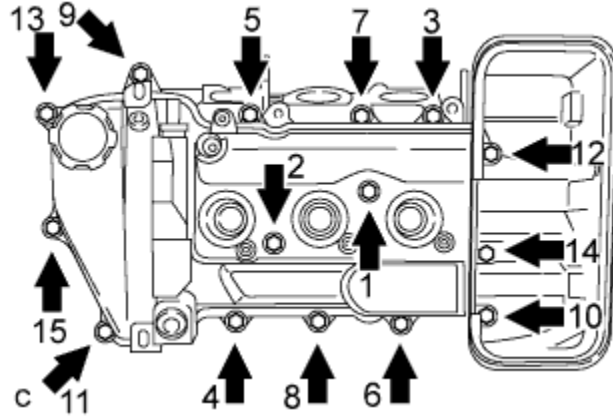

4. Tighten the 13 bolts and 2 nuts to the specified torque in the order shown in the illustration.
Torque:
 $7.7 \text{ N}\cdot\text{m}$ { $77 \text{ kgf}\cdot\text{cm}$, $68 \text{ in.}\cdot\text{lbf}$ }
2. After tightening all of them, make sure that 1 and 2 are tightened to the specified torque shown in the illustration.

48. INSTALL OIL FILLER CAP SUB-ASSEMBLY

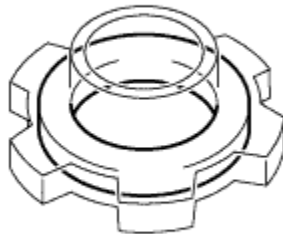

Y

3. Install a new gasket onto the oil filler cap.

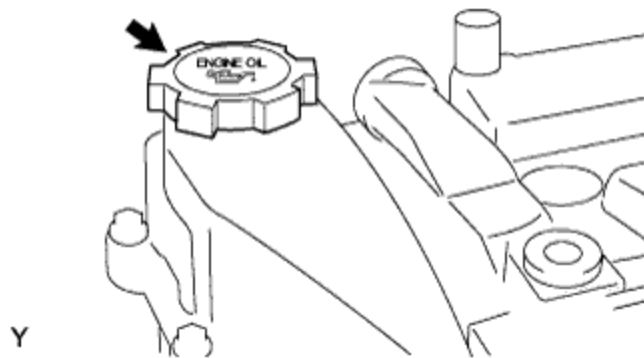

4. Install the oil filler cap.

49. INSTALL OIL CONTROL VALVE FILTER

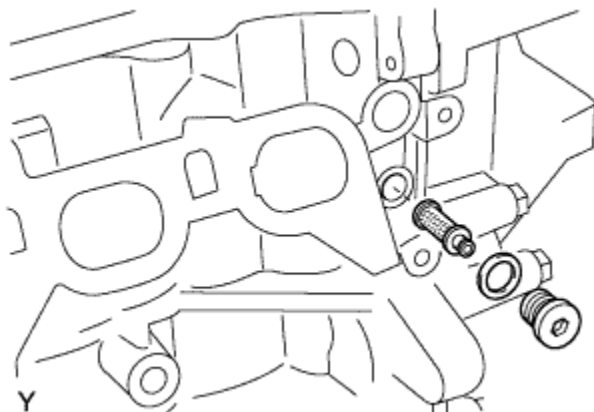

2. Install the oil control valve filter onto the tight plug.

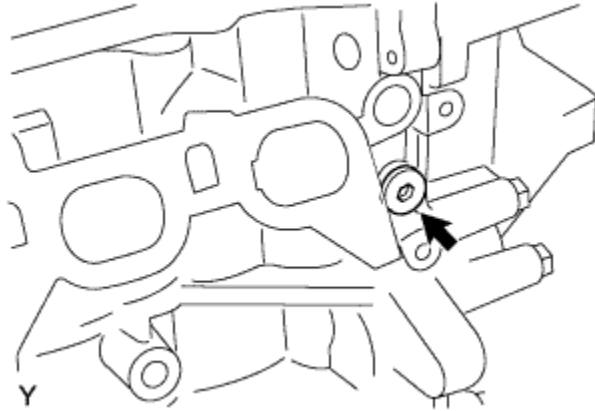

3. Install a new gasket and install the oil control valve filter using a hexagon wrench.
Torque:
25 N*m { 250 kgf*cm , 18 ft.*lbf }

50. INSTALL ENGINE OIL PRESSURE SWITCH ASSEMBLY

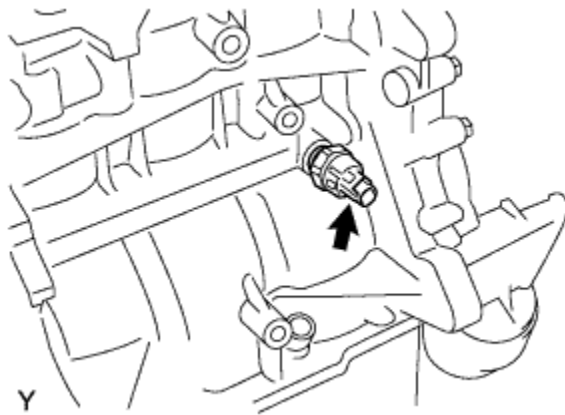

4. Using a 24 mm deep socket wrench, install the oil pressure switch.
Torque:
10 N*m { 102 kgf*cm , 7.0 ft.*lbf }

51. INSTALL OIL LEVEL GAUGE GUIDE

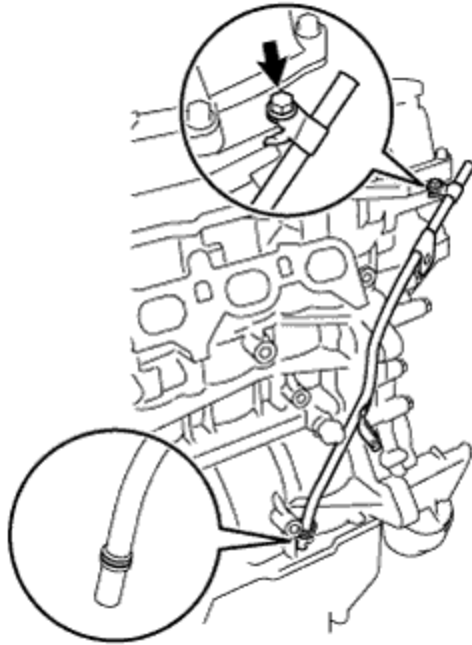

Y

9. Install a new O-ring onto the oil level gauge guide.
6. Apply a light coat of engine oil to the O-ring.
7. Install the oil level gauge guide with the bolt.

Torque:

10 N*m { 102 kgf*cm , 7.0 ft.*lbf }

52. INSTALL OIL LEVEL GAUGE SUB-ASSEMBLY

53. INSTALL CRANKSHAFT POSITION SENSOR

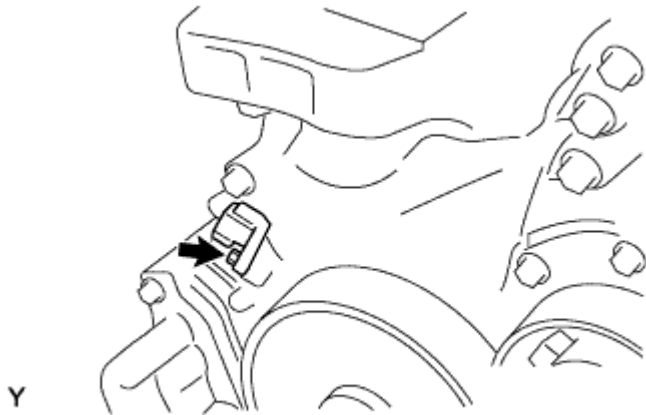

NOTICE:

2. Do not use dropped or hit parts.
 3. Make sure that the O-ring is not damaged before installing it.
 3. Apply light coat of engine oil to the O-ring.
 4. Install the crankshaft position sensor with the bolt.
- Torque:
 7.5 N*m { 77 kgf*cm , 66 in.*lbf }

54. INSTALL CAMSHAFT TIMING OIL CONTROL VALVE ASSEMBLY

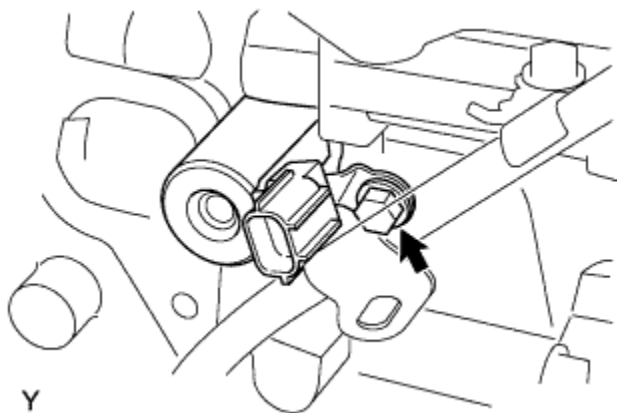

NOTICE:

- Make sure that the O-ring is not damaged before installing it.
5. Apply light coat of engine oil to the O-ring.
 6. Install the camshaft timing oil control valve with the bolt.
- Torque:

10 N*m { 102 kgf*cm , 7.0 ft.*lbf }

55. INSTALL ENGINE COOLANT TEMPERATURE SENSOR

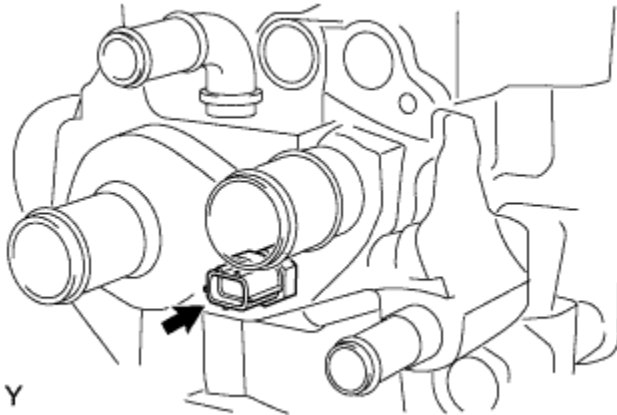

NOTICE:

- Do not use parts that have been dropped or hit.
7. Install a gasket and the water temperature sensor.
Torque:
20 N*m { 200 kgf*cm , 14 ft.*lbf }

56. INSTALL CAMSHAFT POSITION SENSOR

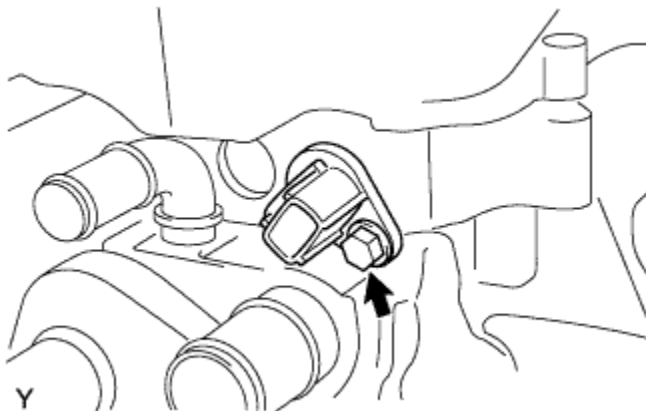

NOTICE:

8. Do not use dropped or hit parts.
9. Make sure that the O-ring is not damaged before installing it.
9. Apply a light coat of engine oil to the O-ring.
10. Install the camshaft position sensor with the bolt.
Torque:
7.5 N*m { 77 kgf*cm , 66 in.*lbf }

57. INSTALL SPARK PLUG

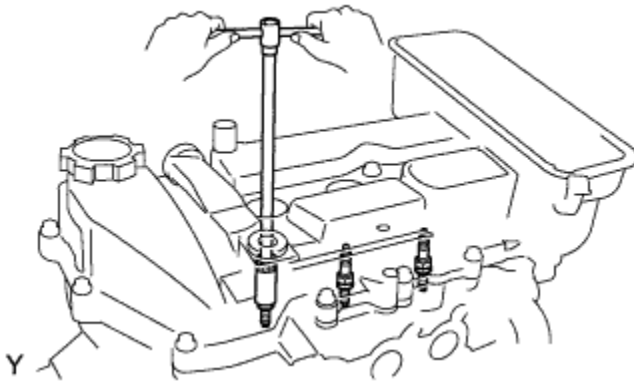

NOTICE:

- Do not use parts that have been dropped or hit.
11. Install the 3 spark plugs.
Torque:
25 N*m { 255 kgf*cm , 18 ft.*lbf }

58. INSTALL ENGINE HANGERS

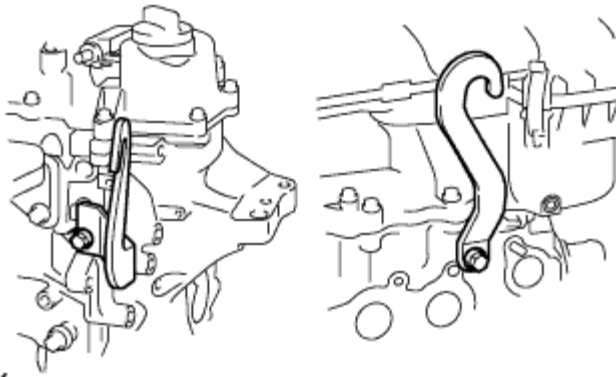

Y

2. Install the 2 engine hangers with the 2 bolts.
Torque:
28 N*m { 285 kgf*cm , 21 ft.*lbf }

ENGINE UNIT > REPAIR

1. REPAIR VALVE SEAT

1. Apply a light coat of prussian blue (or white lead) to the valve face.
2. Gently press the valve against the seat.
NOTICE: Do not rotate the valve.
3. Check the valve face and seat in accordance with the following procedure.
 1. If blue appears 360 ° around the face, the valve is concentric. If not, replace the valve.
 2. If blue appears 360 ° around the valve seat, the guide and face are concentric. If not, resurface the seat.

Standard width:

| Item | Specification |
|---------|--|
| Intake | 1.20 to 1.70 mm (0.0472 to 0.0669 in.) |
| Exhaust | 1.11 to 1.61 mm (0.0437 to 0.0634 in.) |

2. Using a 45 ° cutter, resurface the valve seat so that the valve seat width is more than the specification.
NOTICE:
 1. Repair the seat while checking the seating position.
 2. Gradually reduce the force in order to prevent joggling on the resurfaced face.
3. Check each valve setting position. Using a 45 ° cutter, resurface the valve seat so that the valve seat contacts in the middle of the valve face.

- Using 20 ° and 70 ° cutters, resurface the valve seat so that the valve seat contacts around the entire valve seat and the valve seat width is the specification.

4. Handrub the valve and valve seat with an abrasive compound.